

Keysight Technologies

Testing and Troubleshooting Digital RF Communications Receiver Designs

Application Note

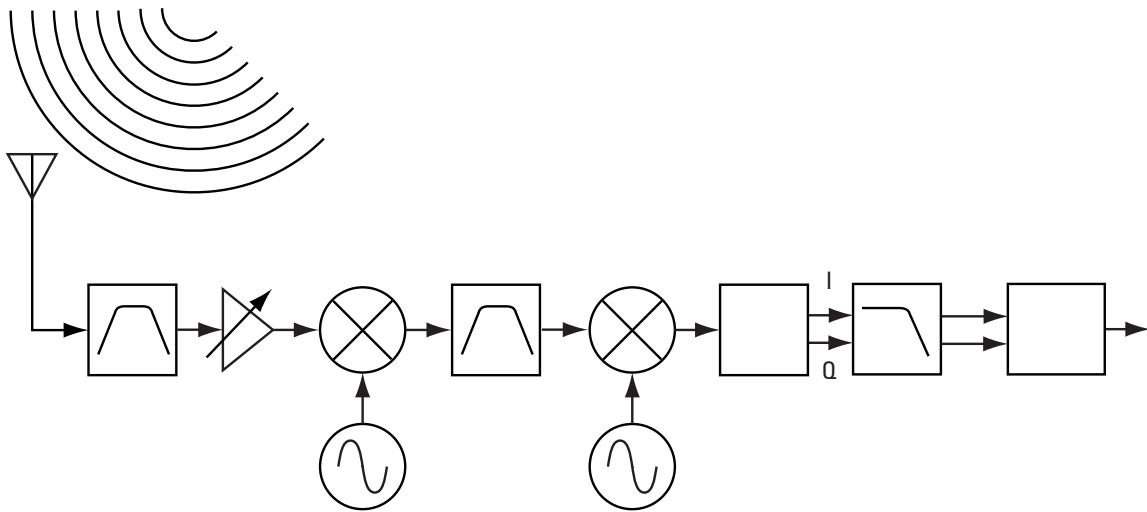



Introduction

This Keysight Technologies, Inc. application note presents the fundamental measurement principles involved in testing and troubleshooting digital RF communications receivers—particularly those used in digital RF cellular systems. Measurement setups are explained for the various receiver tests, and troubleshooting tips are given.

The demand for ubiquitous wireless communications is challenging the physical limitations of current wireless communications systems. Wireless systems must operate in a very limited area of the radio spectrum and not interfere with other systems. The maturing wireless markets are becoming much more competitive, and product cycle times are now measured in months instead of years. Consequently, network equipment manufacturers must produce wireless systems that can be quickly deployed and provide bandwidth-efficient communications.

Digital modulation has several advantages over analog modulation. These include bandwidth efficiency, superior immunity to noise, low power consumption, privacy, and compatibility with digital data services. These advantages, coupled with advances in digital signal processing and in analog-to-digital conversion, have spawned the current migration to digital RF communications formats.

Digital RF communications systems use complex techniques to transmit and receive digitally modulated signals through the radio channel. These complexities challenge designers in the isolation of system problems. Signal impairments can be traced back to a component, device, or subsystem of the digital RF communications system. Successful receiver design depends on the ability to locate sources of error.

The digital radio receiver must extract highly variable RF signals in the presence of interference and transform these signals into close facsimiles of the original baseband information. Several tests verify receiver performance in the presence of interfering signals. These performance verification tests are categorized as either in-channel or out-of-channel measurements.

This application note includes:

- A block diagram of a digital radio communications system.
- Common receiver designs.
- In-channel tests, including sensitivity and co-channel immunity.
- Out-of-channel tests, including spurious and intermodulation immunity and adjacent and alternate channel selectivity.
- Best practices in the receiver performance tests.
- Troubleshooting techniques for receiver designs.
- An appendix that relates Bit Error Rate (BER) to Error Vector Magnitude (EVM).

The setups required to perform the receiver performance tests are included in this application note along with descriptions of potential errors in the measurement process. Troubleshooting techniques applicable to the design of digital radio receivers are also provided.

1. Digital Radio Communications Systems

The digital radio signal experiences many transformations in its migration from a baseband signal at the transmitter to its replication at the receiver. A rudimentary block diagram of a digital radio communications system (Figure 1) reveals the transformation process the signal undergoes from origination to reception.

The system-level diagram in Figure 1 displays the symmetry of the digital radio. To a certain degree, the receiver can be considered a reverse implementation of the transmitter. Consequently, the measurement challenges are similar for both parts of the digital radio system. However, unique problems exist at various locations in the system. For example, the receiver must detect weak signals in the presence of noise and is therefore tested with very low level signals. The transmitter must not interfere with other radio systems and is consequently tested for the amount of interference it produces in the nearby frequency channels.

Certain parts of the digital radio may be implemented in a Digital Signal Processor (DSP), an Application-Specific Integrated Circuit (ASIC), or a Digital Down Converter (DDC). The DSP, ASIC, or DDC has different levels of involvement in the various digital radio designs. Sometimes it is difficult to distinguish those problems originating in the digital portion of the radio from those originating in the analog portion. This application note describes how to isolate and clarify sources of error in digital radio receiver tests and designs.

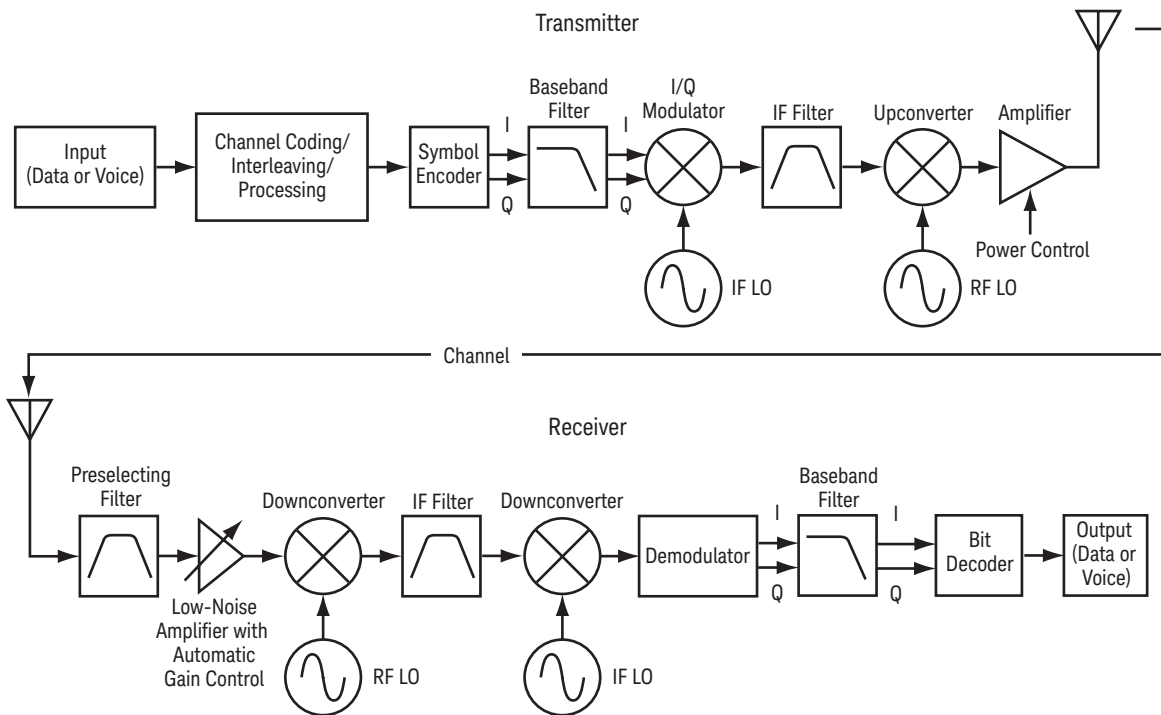

Figure 1. Block Diagram of a Digital Radio System

1.1 Digital Radio Transmitter

The digital radio transmitter (see Figure 1) accepts a baseband waveform and translates that signal into a waveform that it can effectively transmit through the channel. Before the transformation from baseband to a Radio Frequency (RF) channel, the waveform is digitized to utilize the advantages of digital modulation. Coding is applied to the signal to more efficiently use the available bandwidth and to minimize the effects of noise and interference that will be introduced by the channel. The coded signal is filtered, modulated, and changed back to an analog waveform that is converted to the desired frequency of transmission. Finally, the RF signal is filtered and amplified before it is transmitted from the antenna. A more detailed description of digital transmitters can be found in the companion Keysight Technologies application note, *Testing and Troubleshooting Digital RF Communications Transmitter Designs*¹.

1.2 Digital Radio Receiver

The digital radio receiver (Figure 2) can be implemented several ways, but certain components exist in all receivers. The receiver must extract the RF signal in the presence of potential interference. Consequently, a preselecting filter is the first component of the receiver, and it attenuates out-of-band signals received by

the antenna. A Low-Noise Amplifier (LNA) boosts the desired signal level while minimally adding to the noise of the radio signal. A mixer downconverts the RF signal to a lower Intermediate Frequency (IF) by mixing the RF signal with a Local Oscillator (LO) signal. The IF filter attenuates unwanted frequency components generated by the mixer and signals from adjacent frequency channels. After the IF filter, the variations in receiver design manifest themselves.

Of the many different ways to implement a digital radio receiver, most designs fall into two basic categories: I/Q demodulation and sampled IF.

1.2.1 I/Q Demodulator Receiver

I/Q demodulation implemented with analog hardware is a commonly used digital radio receiver design. The function of the analog I/Q demodulator (Figure 3) is to recover the baseband I and Q symbols.

After downconversion to the IF, the signal is separated into two distinct paths. To convert to baseband, each path is mixed with an LO whose frequency equals the IF frequency. The upper-path signal (I) is simply mixed with the LO and then filtered. In the lower

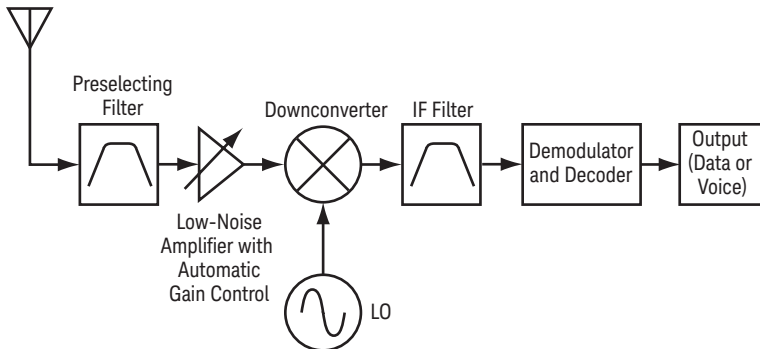

Figure 2. Receiver Block Diagram

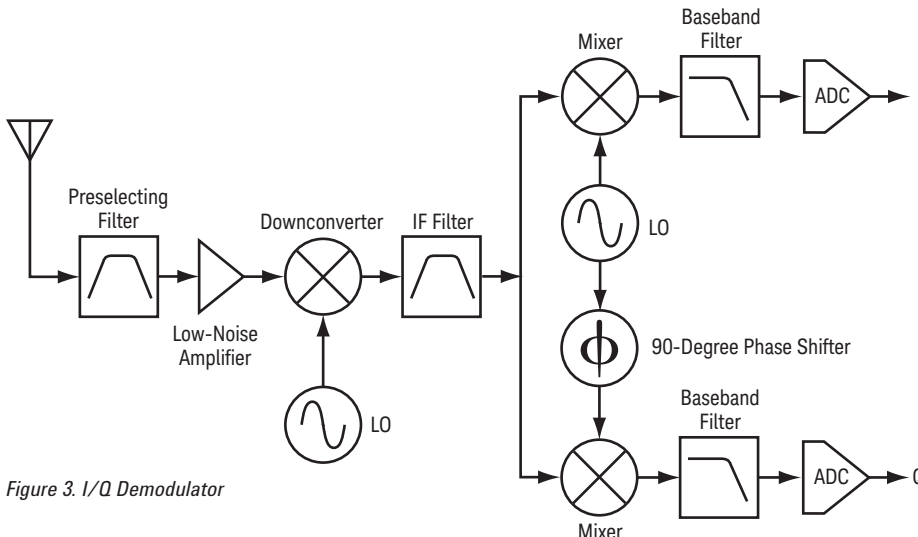

Figure 3. I/Q Demodulator

path, a 90° phase shift is introduced in the mixing signal. This lower-path signal (Q) is converted to baseband by mixing with the phase-shifted LO signal, and then filtered. This process produces the in-phase (I) and out-of-phase (Q) baseband components of the data stream. For a detailed explanation of I/Q modulation, consult the Keysight Application Note *Digital Modulation in Communications Systems —An Introduction*.²

Although the I/Q demodulator receiver is a popular design, it has potential problems. Unequal gain in the I and Q paths and/or a relative phase shift other than 90° (quadrature error) will cause image suppression problems in the baseband mixers. I/Q demodulators inherently produce a spurious response at DC (that is, in the center of the passband) regardless of the input frequency. As a result, I/Q demodulators are most commonly used in single-channel base station receivers that have a separate receiver for each frequency channel, rather than in multi-channel base station receivers that use a single, wide-bandwidth receiver for the entire band of frequencies.

The I and Q data streams are sampled by Analog-to-Digital Converters (ADCs). This allows filtering and signal corrections to be performed with digital signal processing. Baseband filtering by a DSP, ASIC, or DDC removes many of the problems associated with analog filter implementations (for example, phase and group delay problems) and provides filter characteristics closer to ideal than those of analog filters. Baseband filtering, whether it is analog or digital, is better behaved than IF filtering.

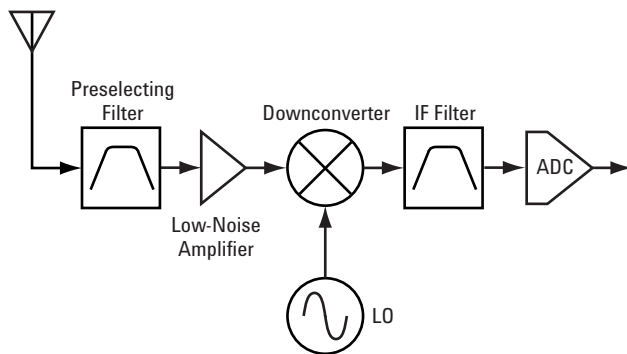

Figure 4. Sampled IF Receiver

1.2.2 Sampled IF Receiver

To decrease analog hardware complexity, the digitally modulated signal can be sampled earlier in the signal path, which increases the digital or software complexity of the receiver design. The sampled IF receiver converts the analog signal to a digital data stream earlier than the I/Q demodulator does (see Figure 4).

In this receiver, the IF signal is digitized. The sampled data stream from the ADC is digitally demodulated into its I and Q components, and the original signal is reconstructed.

This type of receiver is becoming more popular because of advances in ADCs and DSPs. The sampled IF receiver design requires less analog hardware than the I/Q demodulator type and does not split the analog signal into two paths. The I/Q demodulation is actually performed in a DSP, ASIC or DDC. Digital I/Q demodulation avoids phase and amplitude imbalance between I and Q signals. The tradeoff is more digital signal processing and power-hungry ADCs fast enough to capture all the information in the analog signal (two factors that reduce battery life in mobile phones). As with the I/Q demodulator, the sampled IF receiver requires a downconverter that does not degrade the incoming signal.

1.2.3 Automatic Gain Control (AGC)

AGC is used in digital radio receivers to handle the wide range of signal levels encountered at the receiving antenna. AGC compresses the signal range by reducing the gain of the IF, and sometimes the RF, stages as the signal level increases. A strong RF signal can overdrive the mixer and cause excessive signal distortion. The receiver must also process weak RF signals in the presence of noise. Therefore, the RF portion of the receiver may incorporate AGC to process the full range of signal levels presented to it. Used in the IF stage, AGC can prevent overload and maintain a reasonably constant signal input to the demodulator stage. For all applications, the AGC circuitry must maintain allowable levels of signal distortion over a broad range of power levels. Also, the AGC should respond quickly to signal level changes as it processes signals over its entire dynamic range.

1.3 Filtering in Digital RF Communications Systems

Distortion-free transmission of the digital I and Q signals theoretically requires infinite bandwidth. An infinite-bandwidth RF communications system would interfere with other systems and would not provide efficient use of radio spectrum. Filtering narrows the bandwidth of RF systems, but it also slows down signal transitions.

Baseband filtering rounds off the rapid transitions in the transmitted data, but this can cause Inter-Symbol Interference (ISI). A Nyquist filter, which is a type of raised-cosine filter, minimizes ISI by forcing the filter's impulse response to zero at the symbol points (except at the center of the filter). Thus, the time response of the Nyquist filter (Figure 5) goes through zero with a period that exactly corresponds to the symbol spacing. Adjacent symbols do not interfere with each other at the symbol times because the response equals zero at all symbol times except the desired one.

The sharpness of a raised-cosine filter is described by its alpha (α) and quantifies the occupied bandwidth of the signal. An ideal ("brick wall") filter would have an alpha of zero. Typical alpha values range from 0.35 to 0.5. Filter alphas also affect transmitted power. A low alpha value results in low occupied bandwidth but requires high peak transmit power. Consequently, the filter alpha must be carefully chosen to achieve a balance between spectral occupancy and required transmit power. In some systems, a root-raised-cosine filter is implemented at both ends of the digital radio, and the resulting overall filter response is a raised cosine.

Gaussian filters, such as those used in GSM systems, do not provide the theoretical zero ISI like the Nyquist filters do. The Gaussian filter has a Gaussian shape in the time and frequency domains, and it does not go to zero at the symbol spacing. This causes some ISI, but each symbol interacts significantly with only the preceding and succeeding symbols. The bandwidth-time product (BT) of the Gaussian filter corresponds to the alpha of the Nyquist filter, and typical BT values range from 0.3 to 0.5. Unlike Nyquist filters, Gaussian filters are not split into matched pairs in the transmitter and receiver. They are only used in the transmitter. GSM receivers typically use Butterworth filters that have a sharper roll-off than the Gaussian filters. Consequently, sensitivity is improved because less out-of-channel noise and interference is allowed into the receiver's passband.

A more thorough examination of filtering is provided in the Keysight Application Note *Digital Modulation in Communications Systems —An Introduction*.²

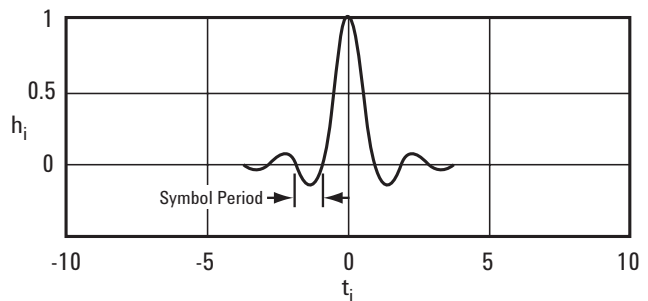

Figure 5. Impulse Response of a Nyquist Filter

2. Receiver Performance Verification Measurements

This section contains test setups and procedures for performance tests on digital radio receivers. Each receiver must meet strict performance criteria defined by the various standards of the telecommunications industry's governing bodies (the ITU, ETSI, TTA, and others). Design teams must develop performance criteria for their receiver, or for a portion of that receiver, and conduct unique performance tests to verify correct implementation and modeling of components in the receiver. More-over, these performance tests verify receiver compliance prior to the design's submission for type approval.

Performance verification tests are divided into in-channel and out-of-channel measurements. In-channel measurements test the receiver's operation within the frequencies occupied by the desired signal. Out-of-channel measurements verify that the receiver is not being adversely affected by (or affecting) other signals outside its specific frequency channel. Although the performance tests presented in this application note focus on digital RF cellular applications, many of the concepts and tests apply to other forms of digital RF communications.

2.1 General Approach to Making Measurements

The most comprehensive receiver test is to evaluate the reconstructed baseband signal that has been processed by the receiver. In this test, one piece of test equipment stimulates the antenna port of the receiver and is considered to be an ideal transmitter. Another instrument monitors the demodulated digital bit stream. If desired, impairments can be introduced by inserting interference in the channel between the source and the receiver, or by altering parameters in the source, to determine the receiver's ability to operate properly under less-than-ideal conditions.

The following tests assume the receiver is complete. If the digital portion of the receiver is unavailable for testing (for example, if it's still under development), then the analog RF designer needs to establish performance goals for the analog portion of the receiver. Typical performance goals are the estimated optimum noise figure for the receiver to pass the performance verification tests and the estimated optimum Signal-to-Noise Ratio (SNR) for proper ADC operation (at the digital conversion point).

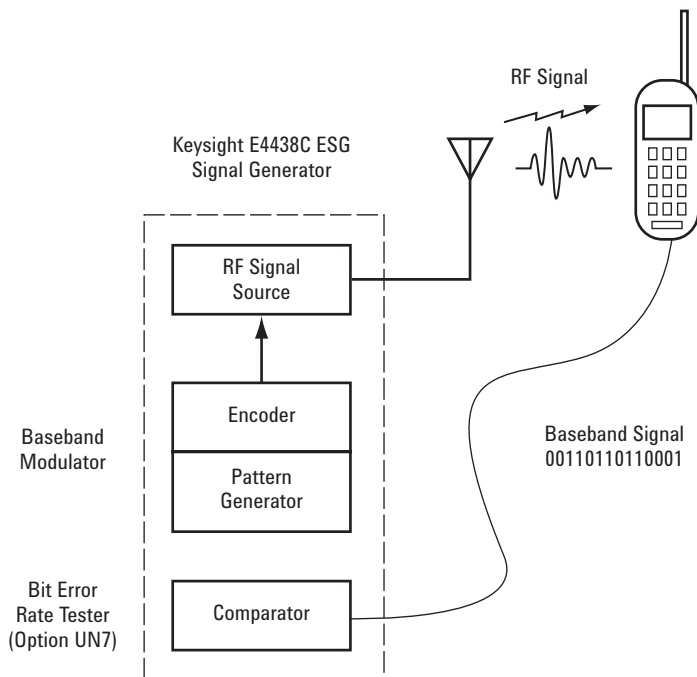

Figure 6. Baseband BER Test Configuration

2.2 Measuring Bit Error Rate (BER)

BER is the fundamental measurement used when testing receiver performance parameters such as sensitivity and selectivity. It is the percentage of erroneous bits received compared to the total number of bits received during an observation period. Virtually all BER⁴ test instruments use a Pseudo-Random Binary Sequence (PRBS) as the test signal. PRBS signals are usually labeled PN_x, where x is the number of bits being permuted in the sequence (for example, PN₉ = 2⁹-1 or 511 bits). Since an entire PN_x sequence can be reconstructed from any sequence of “x” bits, using a PRBS signal eliminates the need to synchronize the received and transmitted bits. Alternatively, the entire PRBS is reconstructed in the BER tester (BERT) receiver from the first correct “x” bits received. The received signal is then compared to the reconstructed correct bit sequence. For a thorough explanation of BER testing, see Keysight Application Note *Measuring Bit Error Rate using the Keysight ESG-D Series RF Signal Generators Option UN7*, literature 5966-4098E³.

Two popular methods exist for BER testing of mobile phones: baseband BER and loopback BER. The feature set of the unit-under-test (UUT) dictates which test method to use. For the baseband BER test, the demodulated PRBS signal at the receiver remains at baseband and is compared to the reconstructed PRBS by the BERT (see Figure 6). Typically, PDC and PHS mobile phones and subassemblies use the baseband BER measurement method.

Conversely, for the loopback BER test the received signal is retransmitted, or looped back to a receiver (Figure 7). In the loopback test, the UUT demodulates the incoming RF signal, decodes it, then re-encodes the data stream (with possible errors), and retransmits the signal, often to the original transceiver. To attain the BER, this received signal is compared to the expected PRBS that is reconstructed by the BERT³. GSM handsets are tested using the loopback method.

The Keysight Technologies, Inc. ESG-D signal generator can be configured to provide the RF signal that carries the PRBS and perform the BER measurement.

Data is managed in telecommunications systems by a hierarchical system of bit grouping. Speech frames are nearly the lowest-level building blocks in this hierarchical system. Not all bits in a speech frame are equally important. Some bits are so important that the entire frame is erased if any of them are bad. This leads to a new parameter for expressing receiver performance—Frame Erasure Rate (FER). It is the percentage of erased frames compared to the total number of frames sent during an observation period. Frame erasure also leads to a modification of our BER measurement. When frames are erased, only the BER of the remaining frames is measured. This parameter is called residual BER (RBER).

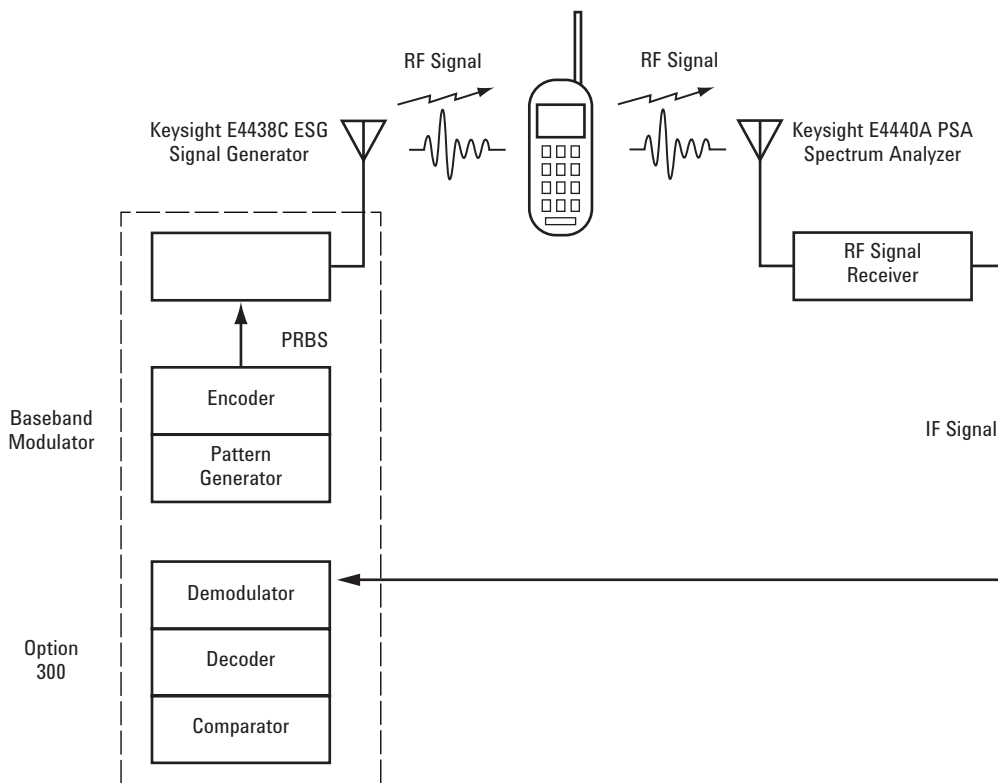
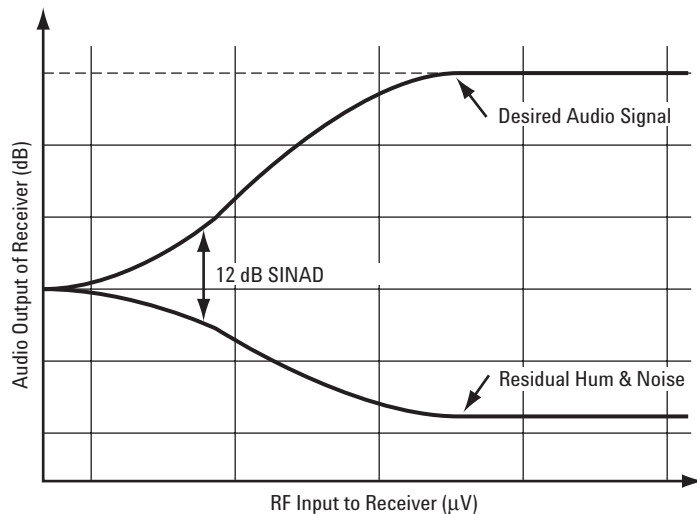

Figure 7. Loopback BER Test Configuration (this test set-up applies only to GSM/EDGE)

2.3 In-Channel Testing

The most significant in-channel test measures the sensitivity of the receiver. Sensitivity specifies the minimum signal level for a specified percentage of errors in the demodulated information. As the separation between transmitter and receiver increases, or as fading occurs in the radio channel, the signal will drop into the noise floor from the perspective of the receiver. Information will be lost when the signal approaches the noise floor. The ability of the receiver to capture the information in a signal as it drops to very low levels is a function of the receiver's sensitivity. The go/no-go method for sensitivity testing is to stimulate the receiver with a very accurate signal set to a relatively low power level and see if the receiver output is acceptable. Alternatively, the signal level is adjusted for a specified SNR or other performance metric. For analog FM receivers, the performance metric is known as SINAD (12 dB is typical). SINAD is the ratio of signal-plus-noise-plus-distortion to the noise-plus-distortion at the same output. Similarly, for digital receivers the specified performance metric is the BER or FER (Figure 8).

Co-channel immunity testing is similar to sensitivity testing. The level of signal distortion is monitored with an interfering signal present in the same RF channel. The interfering signal may be Continuous Wave (CW), narrowband, or of the same type as the desired signal. The ability of the receiver to remain sensitive to the desired signal while subjected to the interfering signal is a measure of its co-channel immunity.



2.3.1 Measuring Sensitivity at a Specified BER

Sensitivity is one of the key specifications for a digital radio receiver and is specified at a particular BER (or FER). Sensitivity is the minimum received signal level that produces a specified BER when the signal is modulated with a bit sequence of data.

Because sensitivity is often expressed in voltage units, such as μV , the following equation will be used to convert to dBm:

$$\text{dBm} = 10 * \log (V_{\text{rms}}^2 / Z_0) + 30$$

where V_{rms} = receiver sensitivity in volts rms
 Z_0 = receiver impedance (typically 50Ω).

For example, if a receiver has a sensitivity expressed as $1 \mu\text{V}$, the sensitivity can be converted to -107 dBm for a system with a 50Ω impedance.

To perform the sensitivity test, connect a signal source to the antenna port of the receiver with a cable of known loss. Then connect the output of the receiver to the BERT. See Figure 9.

Figure 8. Understanding SINAD

The top curve in Figure 8 is the desired audio output of the receiver. As the RF input to the receiver is reduced, this curve falls off. The bottom curve is the residual hum and noise of the receiver. As the RF input is reduced, the AGC of the receiver adds gain, which increases the residual hum and noise. SINAD is the difference between these two curves. The level of RF input required to maintain a SINAD of 12 dB is generally defined as the sensitivity of an FM receiver.

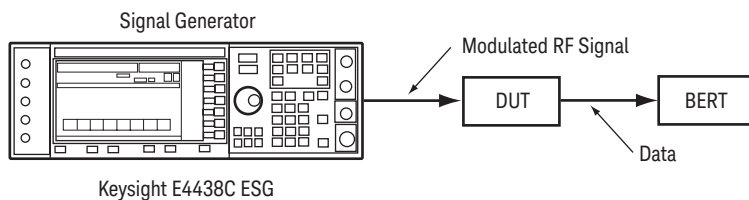

Figure 9. Sensitivity Measurement Setup

If the approximate sensitivity is unknown, the signal level should be set to a nominal level (such as -90 dBm) and decreased until the specified BER occurs. The sensitivity is the power level of the signal minus the loss in the cable. For example, if the signal generator is transmitting a -106 dBm signal when the specified BER is reached and the cable loss is 4 dB, then the sensitivity is -110 dBm for the receiver.

2.3.2 Verifying Co-Channel Rejection

Most receivers are required to maintain a specified BER in the presence of an interfering signal within the channel. Frequently, this co-channel interfering signal will be a CW signal. Figure 10 illustrates the test setup for the co-channel rejection measurement. This setup includes a power combiner that has some power loss associated with it. Maximum insertion loss of most 2-way resistive combiners is near 6 dB when combining two noncoherent signals such as in this test. For all measurements using a power combiner, the combiner loss should be characterized and offset by an increase in signal power from the signal generators.

The frequency of the desired signal, a digitally modulated test signal, is set to the center of the passband of the receiver. The power of this signal is typically set to a level relative to the measured sensitivity of the receiver (for example, 3 dB above). The frequency of the interfering signal is set within the passband of the receiver. The power level of the interfering signal is set to a nominal level at which the BER of the receiver must not exceed the specified level. The required BER level is usually the same level specified for the receiver sensitivity measurement. The difference in power levels between the two signals is the interference ratio.

For example, suppose a 931.4375 MHz pager has a sensitivity of -105 dBm with a BER of 3%. The desired signal is set to 931.4375 with a power level of -102 dBm. At this power level the BER is less than 3%. The channel width for the pager is 25 kHz. The interfering signal is set to 931.4380 MHz. The power level of the interfering signal is first set to -105 dBm and gradually increased until the BER is again 3%. If a level of -97 dBm is required to return the BER to 3%, then the co-channel rejection is 5 dB.

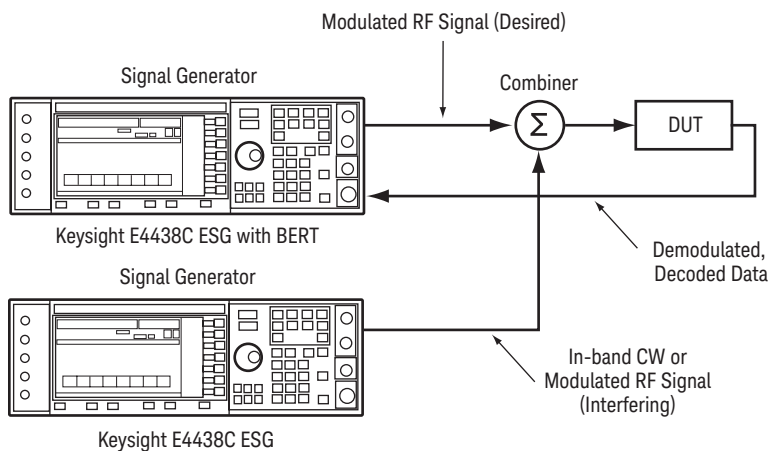

Figure 10. Co-Channel Rejection Measurement Setup

2.4 Out-of-Channel Testing

Out-of-channel, or blocking, tests verify correct receiver operation in the presence of out-of-channel signals and monitor the receiver's susceptibility to internally generated spurious responses. Three prominent out-of-channel tests verify receiver performance: spurious immunity, intermodulation immunity, and adjacent/alternate channel selectivity. For certain digital formats, the single-tone blocking test verifies receiver performance with a large signal in a nearby frequency channel. A large single tone slightly offset from the carrier frequency could desensitize a receiver to the desired signal. The single-tone blocking test is straightforward and will not be covered in this application note.

Spurious immunity is the ability of the receiver to prevent single, unwanted signals from causing an undesired response at the output of the receiver. Spurious immunity is similar to co-channel immunity, but the interfering signals occur across a broad range of frequencies instead of in-channel.

Intermodulation immunity tests for distortion products that are generated when more than one tone is present at the input of the receiver. In this test, two interfering signals are combined with the desired signal at the input of the receiver. The frequencies of the interfering signals are set such that one of the third-order intermodulation products lies within the passband of the receiver. The power of these interferers is raised until the sensitivity of the receiver is compromised.

Adjacent channel selectivity measures the ability of the receiver to process the desired signal with a strong signal in the adjacent channel. Alternate channel selectivity is a similar test in which the interfering signal is two RF channels away from the passband of the receiver.

2.4.1 Verifying Spurious Immunity

Spurious responses, also called spurs, manifest themselves in radio receivers in two ways: they are generated internally by the receiver, or they result from the interaction of the receiver with external signals. Both types of spurs should be identified. Replacing the antenna of the receiver with a load will ensure that the receiver is not picking up any stray signals. Connect the final analog output of the receiver to a spectrum analyzer. Any spur viewed on the spectrum analyzer is internally generated by the receiver and may be a harmonic of the power supply, a harmonic of the system clock, or a spur from an LO.

Spurious response immunity is a measure of the receiver's ability to prevent single, unwanted signals from causing an undesired response at the output of the receiver. Prior to making this measurement, the internally generated spurs must be identified (as described above) and should be below the specified level. To perform the spurious immunity measurement, one signal generator supplies a modulated test signal in the desired RF channel at a level above the sensitivity of the receiver (usually 3 dB above). The second signal generator supplies an interfering signal. This interfering signal is adjusted to several frequencies to verify the receiver's immunity to spurs. Refer to Figure 11.

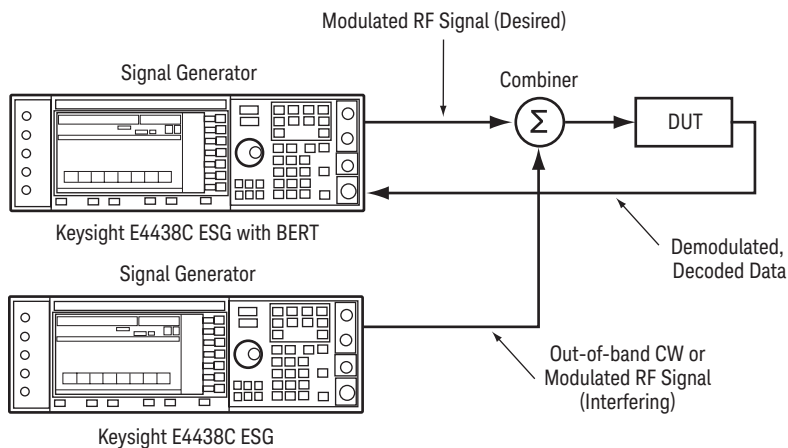

Figure 11. Spurious Immunity Measurement Setup

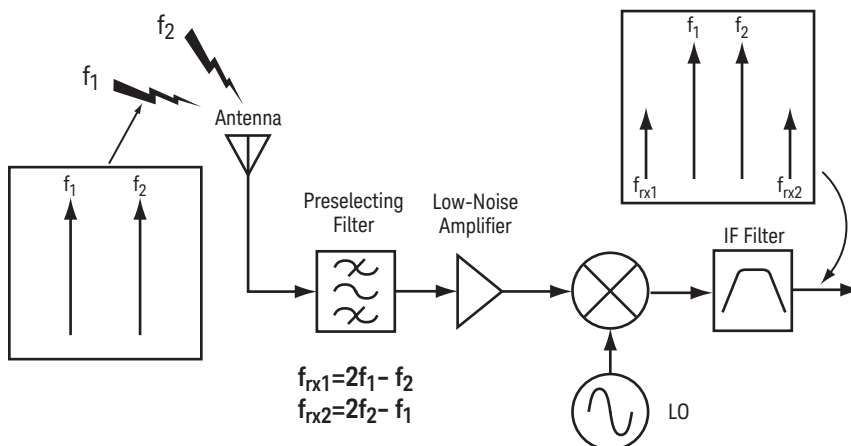

Figure 12. Intermodulation Products

The interfering signal may be modulated or unmodulated, depending upon the frequency range and the communications standard. The output amplitude of the interfering signal is set at a specific level at which the BER of the receiver under test must be less than a specified level (usually the BER specified in the sensitivity test). The amplitude difference between the test signal and the interfering signal is the spurious immunity (SI) of the receiver:

$$SI = P_{int} - P_{test} \text{ (dB)}$$

Spurs from the signal generator used to provide the interfering signal can cause a good receiver to appear bad. Any spurs created by the interfering signal generator should be less than the receiver's spurious immunity.

2.4.2 Verifying Intermodulation Immunity

Intermodulation products may be generated within the receiver when more than one signal is present at the input of the receiver. Intermodulation products are caused by receiver non-linearities. Two-tone intermodulation is a common method of testing a receiver. The test signal is the same signal used in other measurements (for example, spurious immunity). The frequencies of the interfering signals are set such that one of the third-order intermodulation products ($f_{rx1} = 2f_1 - f_2$ and $f_{rx2} = 2f_2 - f_1$) falls within the passband of the receiver. See Figure 12.

The power levels of the interfering signals are set equal to each other at a specified level, and the BER of the desired signal is checked. As with other receiver tests, the required BER level is usually the BER at which the sensitivity is measured.

Whenever two signals are input to a combiner, the nonlinearities of the signal generators may create intermodulation products (see Figure 13). There are several techniques for reducing signal generator intermodulation products:

- 1) maintain a frequency separation between the interfering signals that is greater than the bandwidth of the Automatic Level Control (ALC) of the sources;
- 2) add attenuators to the outputs of the signal generators;
- 3) use hybrid combiners;
- 4) use isolators;
- and 5) turn off the ALC of the sources.

All these techniques may be applied simultaneously to reduce intermodulation products. Maintaining a large frequency separation is usually the most effective means to combat this problem. For example, if the ALC bandwidth is 1 kHz, the signal separation should be at least 10 kHz. If this cannot be done, adding attenuation at the signal generator outputs theoretically reduces the intermodulation products 3 dB for every 1 dB of attenuation.

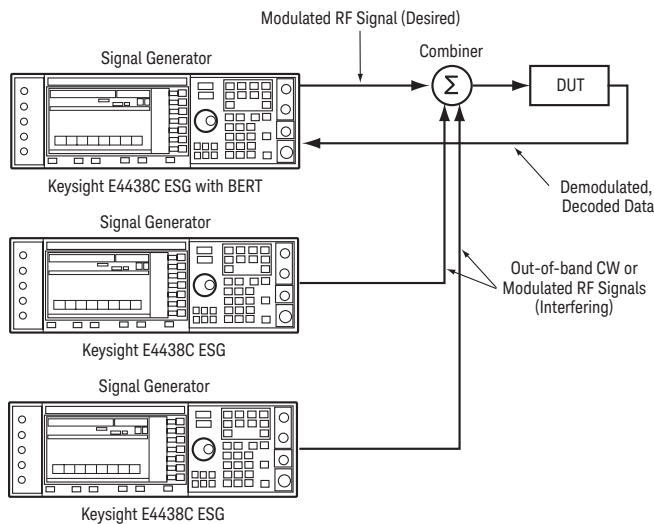

Figure 13. Intermodulation Immunity Measurement Setup

2.4.3 Measuring Adjacent and Alternate Channel Selectivity

Adjacent and alternate channel selectivity measure the receiver's ability to process a desired signal while rejecting a strong signal in an adjacent channel (one channel away) or alternate channel (usually two channels away). The selectivity tests are very important for communications receivers in which channel spacings are narrow and adjacent and alternate channel power is hard to control (for example, Specialized Mobile Radio, or SMR). An adjacent and alternate channel selectivity test setup is shown in Figure 14. One signal generator inputs a test signal at the desired channel frequency at a level relative to the sensitivity of the receiver (usually 3 dB above). The second signal generator inputs either the adjacent channel signal, offset by one channel spacing, or the alternate channel signal, offset by two channel spacings. The out-of-channel signal is set to a specified level at which the BER of the test signal is below a certain rate (usually the same level specified in the sensitivity test).

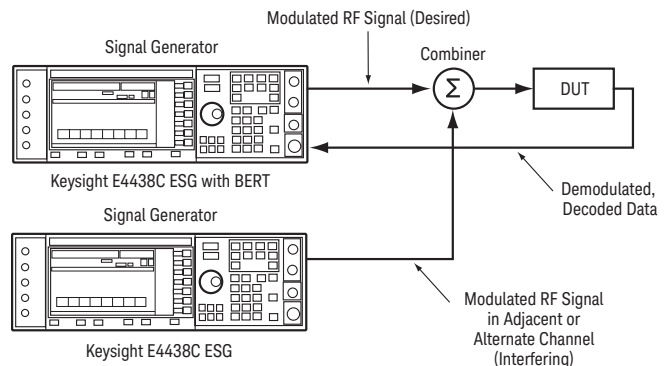

Figure 14. Adjacent and Alternate Channel Selectivity Test Setup

For example, the sensitivity of an NADC base station receiver is specified at -110 dBm with a BER of 10^{-3} , or 0.1%. The adjacent channel specification requires that the BER be no worse than 10^{-3} with the in-channel signal set to -107 dBm, a 3 dB increase, and the adjacent channel signal set to -94 dBm, or 13 dB above the in-channel signal level. This implies that the adjacent channel signal cannot increase the receiver noise floor by more than 3 dB. For alternate channel selectivity, the alternate channel signal is set to -65 dBm, or 42 dB above the in-channel signal level. Figure 17 displays the specified NADC adjacent and alternate channel selectivity spectrum.

In addition to level accuracy, the spectral characteristics of the test and interfering signals are important. For many receivers, the single sideband (SSB) phase noise of the signal generator used to produce the interfering signal is a critical spectral characteristic. If the phase noise energy inside the passband of the IF filter is excessive, the receiver may appear to fail the test. This is illustrated in Figure 15.

The required signal generator SSB phase noise may be calculated from:

$$\Phi_n = P_{ac} - 10 * \log(1/B_e) + P_{mar}$$

where

Φ_n = signal generator SSB phase noise (dBc/Hz) at the channel spacing offset

P_{ac} = adjacent or alternate channel selectivity specification (dB)

B_e = receiver noise-equivalent bandwidth (Hz)

P_{mar} = test margin (dB)

Since P_{ac} and B_e are fixed by the specifications or design, the test margin determines the power that the signal generator phase noise will be allowed to contribute to the IF passband of the receiver. A large test margin increases the confidence that the receiver operates properly in the presence of SNR degradation due to fading in the channel or due to imperfections in receiver components. For a system using a new technology or new operating frequencies, a large test margin should be used to compensate for uncertainties.

For a receiver with a noise-equivalent bandwidth of 14 kHz, a P_{ac} at the adjacent channel of 70 dB, a margin of 10 dB, and a channel spacing of 25 kHz, the required SSB phase noise is -122 dBc/Hz at a 25 kHz offset. This is typical for an analog FM receiver. Unlike the FM receiver in this example, most digital communications receivers have adjacent channel selectivity values less than 15 dB. For a GSM receiver with a noise-equivalent bandwidth of 200 kHz, a P_{ac} at the adjacent channel of 9 dB, a margin of 10 dB, and a channel spacing of 200 kHz, the required SSB phase noise is -72 dBc/Hz at a 200 kHz offset. The required SSB phase noise is driven primarily by P_{ac} .

Table 1 lists the values of adjacent and alternate channel selectivity for various communications systems as well as the required signal generator SSB phase noise. A 10 dB test margin was used. Clearly, for the digital RF communications formats, the signal generator SSB phase noise is not as important as for analog FM systems.

For selectivity tests the spectral shape of the signal is the special characteristic that is of primary importance. The digital modulation formats used by GSM, CDMA, NADC, and PDC characteristically leak a small amount of power into the adjacent channels. Figures 16–18 plot amplitude versus frequency for the selectivity values specified in Table 1. The impact of the spectral shape on the adjacent and alternate channels of the receiver is evident. To properly test your digital radio receiver, the Adjacent Channel Power (ACP) of your signal generator must be below the required system specification plus the desired test margin.

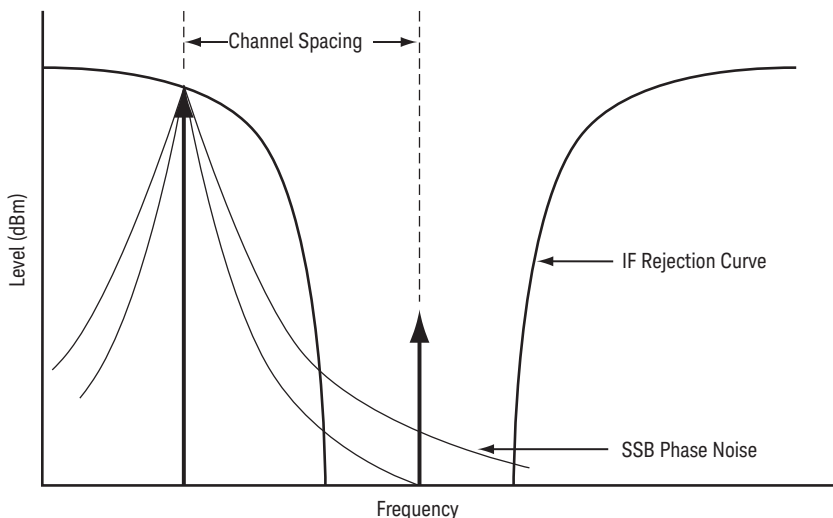

Figure 15. Phase Noise in Adjacent Channel Selectivity

Table 1. Maximum Tolerable SSB Phase Noise

SystemType	Channel Spacing	Approximate Reciever Noise Bandwidth	Adjacent Channel Selectivity	Maximum SSB Phase Noise @ Offset	Alternate Channel Selectivity	Maximum SSB Phase Noise @ Offset
Analog FM	25 kHz	14 kHz	70 dB	-122 dBc/Hz @ 25 kHz		
GSM	200 kHz	200 kHz	9 dB	-72 dBc/Hz @ 200 kHz	41 dB	-104 dBc/Hz @ 400 kHz
NADC	30 kHz	35 kHz	13 dB	-68 dBc/Hz @ 30 kHz	42 dB	-97 dBc/Hz @ 60 kHz
PDC	25 kHz	33 kHz	1 dB	-56 dBc/Hz @ 25 kHz	42 dB	-97 dBc/Hz @ 50 kHz

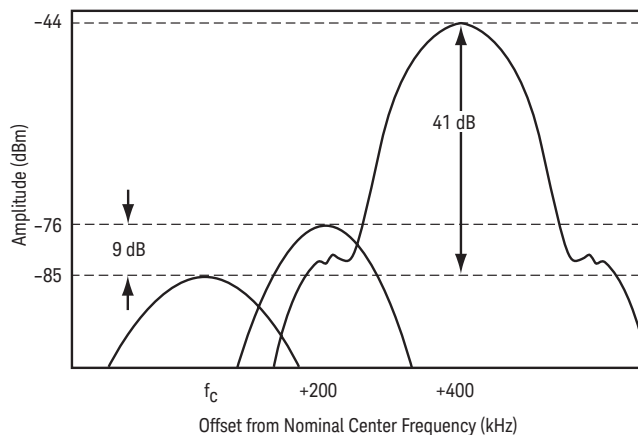

Figure 16. GSM Adjacent and Alternate Channel Selectivity Spectrum

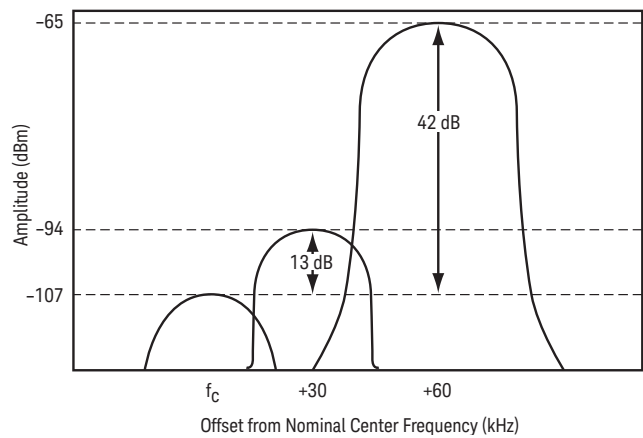

Figure 17. NADC Adjacent and Alternate Channel Selectivity Spectrum

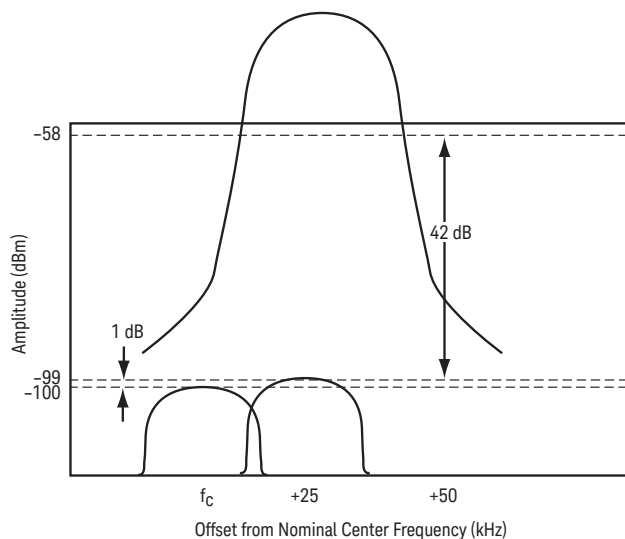

Figure 18. PDC Adjacent and Alternate Channel Selectivity Spectrum

2.5 Fading Tests

A unique challenge for the receiver is to overcome the random effects of the radio channel. In a cellular environment, a radio signal may take a number of paths en route from the transmitter to the receiver. These multipath signals may add up constructively (in phase) or destructively (out of phase) at the receiver as a function of the distance each signal travels. The effect of this phenomenon can be fading of the received signal strength, which can greatly stress signal reception. Fast fading distorts the shape of the baseband pulse. This distortion is linear and creates ISI. Adaptive equalization reduces ISI by removing linear distortion induced by the channel. Slow fading results in a loss of SNR. Error-correction coding and receive diversity are used to overcome the effects of slow fading.

Fading tests can be performed by routing the test signal through a radio-channel emulator such as the Keysight 11759C RF channel simulator before the signal is processed by the receiver. This device provides several paths for the signal to travel in the simulated RF channel before being recombined at the receiver. The receiver must be able to process fading signals with an acceptable BER. The fading measurement setup (Figure 19) is similar to the sensitivity measurement setup with the exception of the channel simulator.

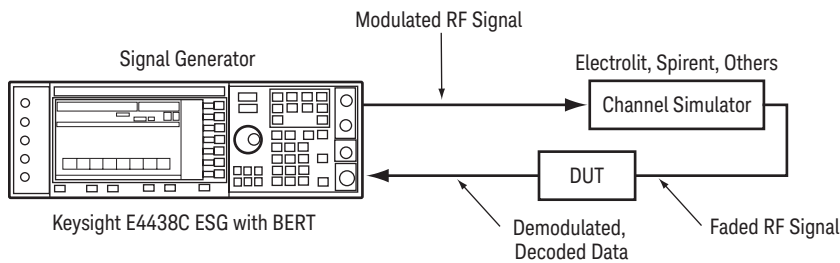

Figure 19. Fading Measurement Setup

2.6 Best Practices in Conducting Receiver Performance Tests

By following certain guidelines in conducting receiver performance verification tests, you can be sure that your test results are valid. Performing in-channel and out-of-channel receiver tests within the confines of a shielded room greatly reduces interference from outside sources. The shielded, or screen room provides isolation from RF signals that could potentially interfere with the receiver. Also, impedance mismatches between the signal generator and the receiver create reflections that degrade measurement accuracy. The test equipment used to conduct receiver tests should be carefully chosen to reduce measurement uncertainties and increase confidence in proper receiver operation.

When making a sensitivity measurement, the level accuracy of the signal generator is extremely important. The measurement system will introduce some amount of error, and the amplitude level accuracy of the signal generator is the main source of this error. In addition to level accuracy, the signal generator must also have accurate modulation. Distortion in the signal modulation will degrade the sensitivity of the receiver being tested.

When measuring the adjacent channel selectivity performance of an analog radio receiver, the phase noise of the out-of-channel test signal is extremely important. Conversely, when making out-of-channel tests on digital radio receivers, the phase noise of the test signal is much less important. The power in the modulation sidebands of the test signal greatly exceeds the power contribution from the phase noise sidebands. The portion of the test signal that spills over into the adjacent channel has the greatest impact on the out-of-channel testing of digital radio receivers. Because of this, ACP is the most important specification for out-of-channel test signals.

3. Troubleshooting Receiver Designs

Digital RF communications systems require complex digital radio transmitters and receivers. Complex designs challenge engineers in the isolation of system problems. Most physical impairments can be traced back to a component, device, or subsystem. Successful receiver design often depends upon the ability to find the source of error. This section suggests some basic techniques for troubleshooting a receiver that does not pass a certain test. Also, a table that links measurement characteristics to possible causes of error in the different sections of the receiver is provided.

3.1 Troubleshooting Steps

If the receiver under test fails any of the performance tests, you should attempt to isolate the source of the error in the receiver. The following is a suggested troubleshooting procedure to follow if your receiver does not meet the expected performance criteria.

Test Failed:

1. Sensitivity. Measure the BER versus the input power. If the BER is high at high input powers, check for I/Q impairments (see section 3.2.1), excessive group delay in analog components, or phase noise from an LO. If the BER is high at low input powers, measure the noise figure of the analog front end (from the antenna port to the ADC). If the noise figure is higher than expected, measure the noise figure and gain (or loss) of each stage of the receiver. If no noise figure problems are detected, the gain of the front end may be low, there could be a detection algorithm problem in the digital portion of the receiver, or a spur may be desensitizing the receiver (see section 3.2.2).
2. Co-channel immunity. Check for compression occurring in the analog components or check for an algorithm implementation problem in the digital realm.
3. Spurious immunity. Look for any interfering tone (see section 3.2.2). If no interfering tone is found, perform a Fast Fourier Transform (FFT) on the data from the ADC to convert to the frequency domain. Then check for spurs generated by the ADC.
4. Intermodulation immunity. Measure the third-order intercept (TOI) of the RF front end. If it meets the expected value, measure the TOI and gain of each analog stage.
5. Selectivity. Look at the shape of the IF filter (see section 3.2.5), and check for excessive LO phase noise or sidebands.

Specific guidelines should be followed when connecting to the receiver during troubleshooting. When connecting to analog nodes of the receiver, the test probe alters signal characteristics to a certain degree, which increases uncertainty in the test results. In a conventional analog receiver there are many accessible test points, such as the outputs of the LNA, the LO, the mixers, and the various filters. Accessibility of components in the digital radio receiver depends on the level of circuit integration. Many of the components of receiver subsystems are embedded in Integrated Circuits (ICs). For receivers containing ICs, tests are normally conducted at the subsystem levels of the receiver. To test embedded components, strategic test points must be designed into the IC.

A noise figure measurement on the RF front end, or any analog component or subsystem of the receiver, is a two-port measurement (from input to output). For more information on noise figure measurements, see Keysight Application Note *Fundamentals of RF and Microwave Noise Figure Measurements*⁶. The TOI measurement is also a two-port measurement.⁷ ADC measurements process the digital output of the ADC and are unaffected by probe placement.

3.2 Signal Impairments and Ways to Detect Them

Certain signal impairments appear in specific measurements. In these measurements, variations from the expected results can help locate problems in different parts of the receiver. The following sections explain some common impairments and how to recognize them through their effects on the different measurements. With the exception of the IF filter measurement, the Keysight 89441A vector signal analyzer (VSA) is used to troubleshoot receiver designs in this application note. The IF filter measurement is performed with the Keysight 8753E vector network analyzer (VNA).

3.2.1 I/Q Impairments

Constellation diagrams are useful in displaying the characteristics of signal impairments related to I and Q. Matching problems due to component differences between the I side and Q side of a receiver can cause gain imbalance or quadrature errors. These differences may be attributed to mixers, filters, or ADCs. Subtle imbalances are detectable by viewing the constellation diagram of the symbol time and comparing with the ideal grid of the constellation. These ideal grids indicate where the symbol states should occur.

I/Q gain imbalance results in a distorted measured constellation relative to the reference (see Figure 20). This imbalance may be caused by slightly different conversion losses in the I and Q mixers or by different filter losses in the I and Q signal paths of an I/Q demodulator. Even subtle imbalances are often visually detected by zooming in (magnifying the scale) on the constellation and using the markers. Without the ideal grids it would be difficult to detect small imbalances.

I/Q quadrature errors result in a tipped or skewed constellation (Figure 21). Quadrature errors are caused by a phase shift other than 90° between the I and Q paths. Different group delays in the baseband I and Q filters also create quadrature errors. This distortion of the constellation increases the possibility of errors in the interpretation of the received symbols and will increase the Error Vector Magnitude (EVM).

I/Q offsets are shifts in the origin of the I/Q constellation and can occur when DC offsets are introduced by rounding errors in the DSP or by LO feedthrough in the transmitter (see Figure 22).

3.2.2 Interfering Tone or Spur

An interfering signal can cause the amplitude and phase of the transmitted signal to be different each time the signal passes through the same state. This will result in a spread at the symbol locations in the constellation diagram (Figure 23). Random smearing of the points indicates noise, but a circling of the symbols around the constellation states indicates there may be a spur or interfering tone. The radius of the circle is proportional to the amplitude of the interfering signal, but this display format contains no information about the interfering frequency, which may be the key to identifying the cause.

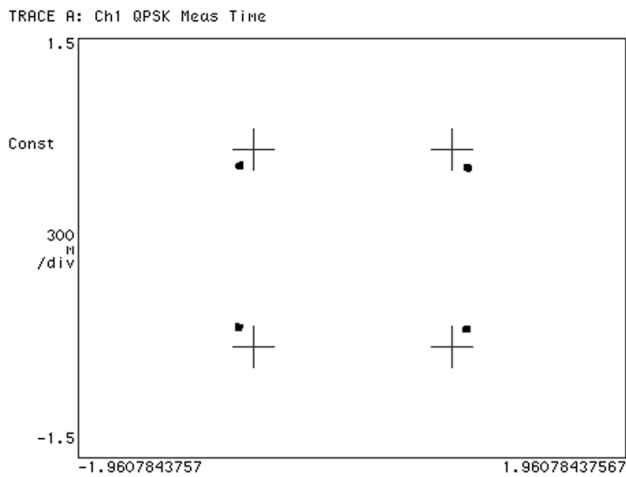

Figure 20. I/Q Gain Imbalance (excess I gain and reduced Q gain relative to the ideal constellation locations)

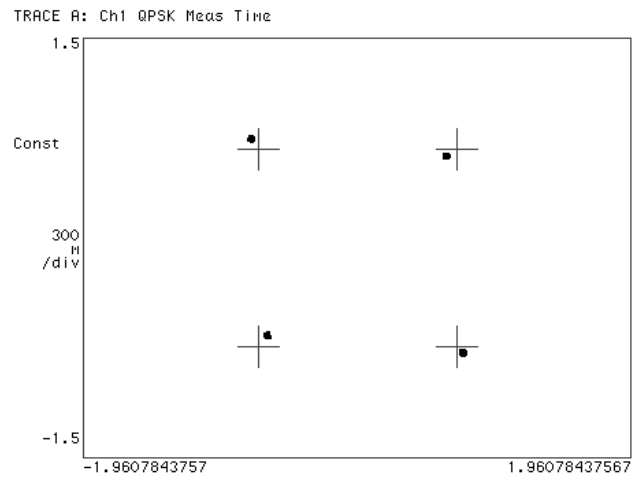

Figure 21. I/Q Quadrature Error

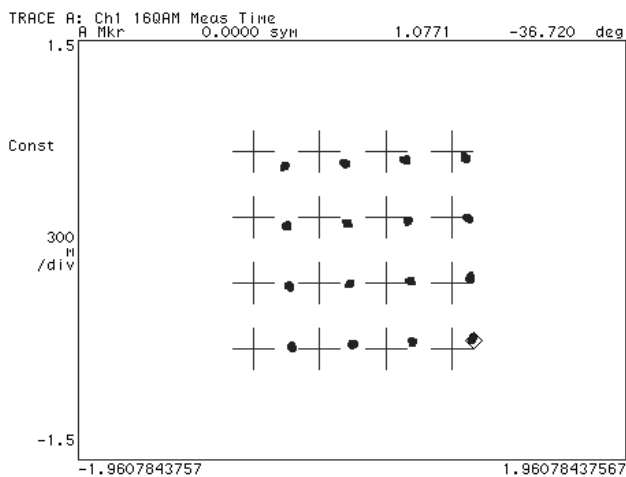

Figure 22. I/Q Offset

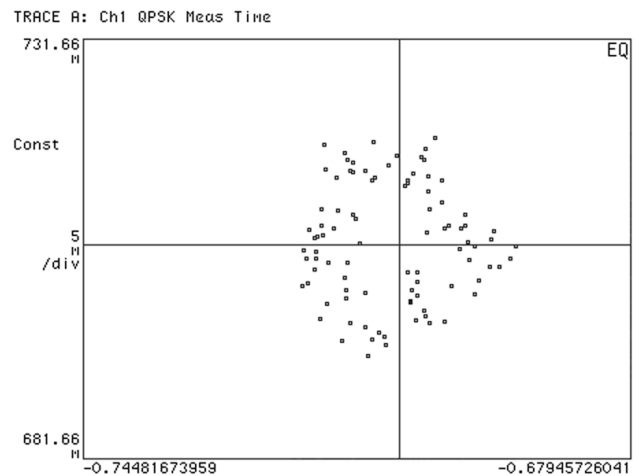

Figure 23. A Sinusoidal Spur Indicated by the Circle Around One of the Constellation Points

The presence of spurs on a modulated signal may be difficult to determine on a constellation display or through spectrum analysis. An alternative parameter can be used to check signal quality: EVM. A description of EVM and how it relates to the BER can be found in the Appendix. The magnitude of the error vector versus time graph may hint that the error observed is sinusoidal in nature, but what is really needed is a method to determine the frequency of the spur.

The error vector spectrum can indicate the frequency of spurious signals that cannot be observed on traditional spectrum analyzers or on a constellation display. In Figure 24, a spur offset from the carrier by approximately 47 kHz is detected at the output of the IF filter. This spur was most likely caused by an in-band CW signal undetectable by traditional spectrum analysis (see Figure 25). This in-band CW interferer could be a harmonic of the processor clock, an intermodulation product, or an internally generated spur. This interfering tone could cause the receiver to fail many of the performance verification tests.

3.2.3 Incorrect Symbol Rate

The symbol clock of a digital radio dictates the sampling rate of the baseband I and Q waveforms required to accurately interpret the symbols and recover the digital data at the receiver. In the transmitter, the symbol rate dictates the creation of the baseband I and Q waveforms to properly put the valid states in the correct locations, ensuring proper encoding of the digital data. It is imperative that the transmitter and receiver have the same symbol rate to be compatible.

An internal clock generator determines the symbol rate of a system. This generator must be set correctly. Symbol rate errors often occur when the wrong crystal frequency is used (for example, if two numbers have been accidentally switched in the frequency specification). If no problem exists with the crystal, the receiver is having a synchronization problem. Either the receiver is not properly recovering the carrier frequency, or the receiver is not achieving symbol lock. To recover the proper carrier frequency, the receiver must lock onto the phase of the carrier. To accurately extract the symbols from the carrier, the receiver must also determine when symbol transitions occur. A timing recovery loop provides the mechanism for the receiver to achieve the necessary symbol lock. When the receiver does not achieve proper phase lock and/or proper symbol lock, symbol rate errors occur. If you suspect an incorrect symbol rate and no problem exists with the crystal, verify proper operation of the carrier and timing recovery circuitry of the receiver.

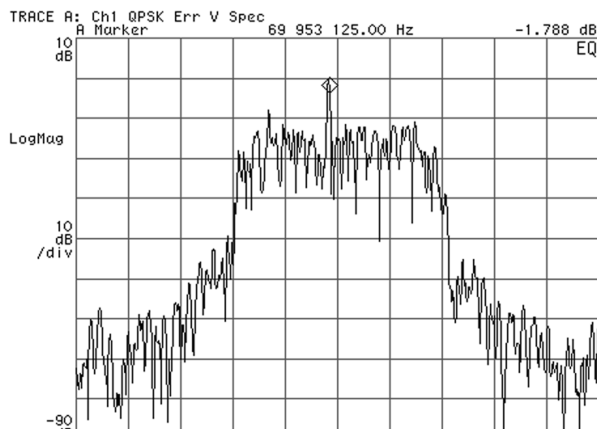

Figure 24. Error Vector Spectrum Reveals Spur

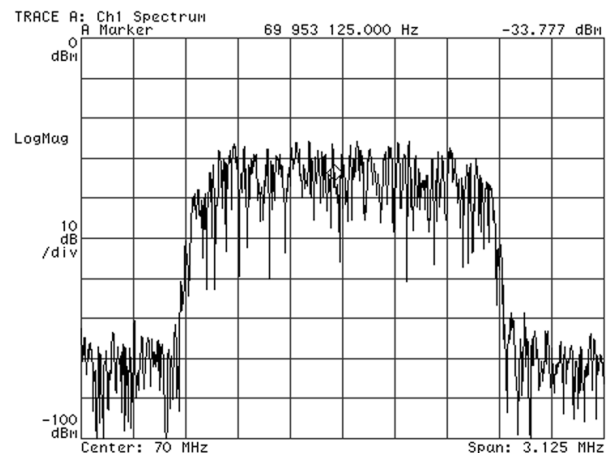

Figure 25. Signal Spectrum Conceals Spur

3.2.4 Baseband Filtering Problems

Baseband filtering must be correctly implemented to provide the desired baseband frequency response and to avoid ISI as well as overshoot of the baseband signal in time. The alpha parameter in a raised-cosine filter defines the shape of the filter in the frequency domain. A low alpha creates a sharp filter shape in the frequency domain, but also creates high overshoot in the time domain, which can be recognized on a vector diagram. It is important to verify that the receiver has the appropriate baseband frequency response and time characteristics for the specified alpha.

In cases where baseband filtering is shared between the transmitter and the receiver, the filters must be compatible and correctly implemented in each. The type of filter and the corresponding roll-off factor (alpha) are the key parameters that must be considered. For raised-cosine filters, an error in the selection of alpha may result in undesirable amplitude overshoot in the signal. It may also result in ISI. Incorrect filtering due to a wrong roll-off factor may affect the amount of interference from an adjacent channel signal. This could cause an otherwise good receiver to fail many of the performance verification tests.

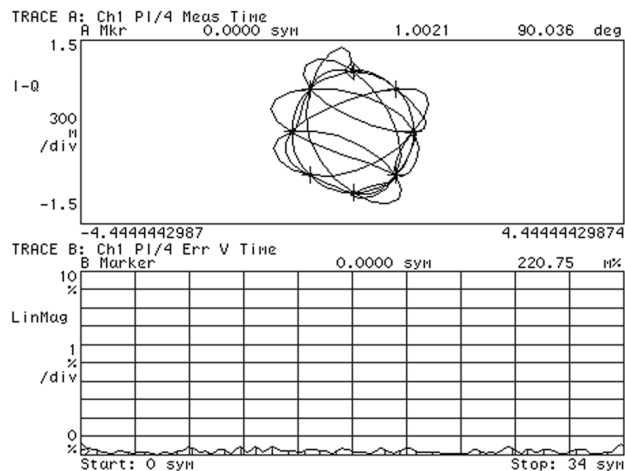

Figure 26. Vector Diagram and Magnitude of the Error Vector Versus Time for Wrong Roll-off Factor

To verify baseband filter performance, examine the vector constellation diagram for excessive overshoot of the signal trajectory between symbol states. The magnitude of the error vector versus time would be a good indicator of roll-off factor discrepancies. If the wrong roll-off factor is used, the magnitude of the error vector will be high between symbol points and low at the symbol points (see Figure 26).

The correct roll-off factor can be found by using different roll-off factors in the VSA while viewing the error vector time display. When the correct value is used, the magnitude of the error vector between symbol decision points will be approximately equal to the magnitude of the error vector at the decision points (Figure 27). Furthermore, equalization can be applied to decrease the errors caused by baseband filtering problems.

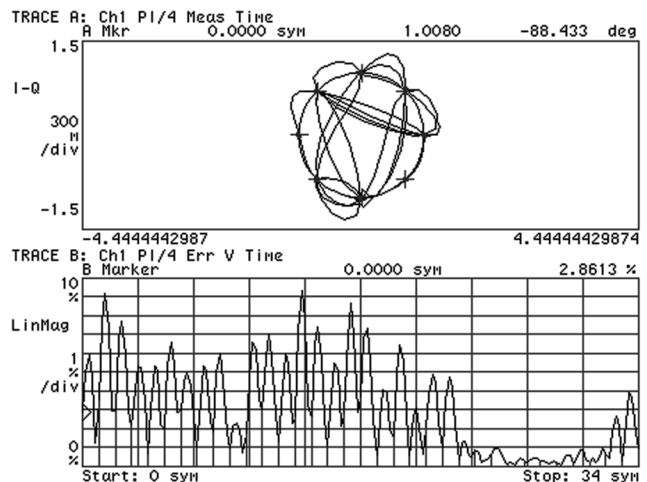

Figure 27. Vector Diagram and Magnitude of the Error Vector Versus Time for Correct Roll-off Factor

3.2.5 IF Filter Tilt or Ripple

The IF filter attenuates out-of-channel interference. Errors in the design of this filter can affect the overall signal. IF filter problems include filter tilt or ripple in the frequency response and variations in group delay. Ideally, the filter should be flat across the frequency band of interest, and its group delay should be constant across the same frequency band. Filter tilt or ripple in the frequency response causes linear distortion in the signal. Improper matching of any component between the antenna and the IF filter also causes tilt or ripple. For example, mismatch between the preselecting filter and the LNA causes reflections that result in distortion of the overall frequency response of the receiver.

Filter tilt or ripple causes distortion on the demodulated baseband signal. This distortion is discernible in the constellation diagram. Also, the magnitude of the error vector will be higher than expected at the symbol points as well as during symbol transitions. Since the IF filter is the main contributor to the frequency response of the receiver, IF filter shape distortion is observed and analyzed by performing a frequency response measurement on the filter alone, as shown in Figure 28.

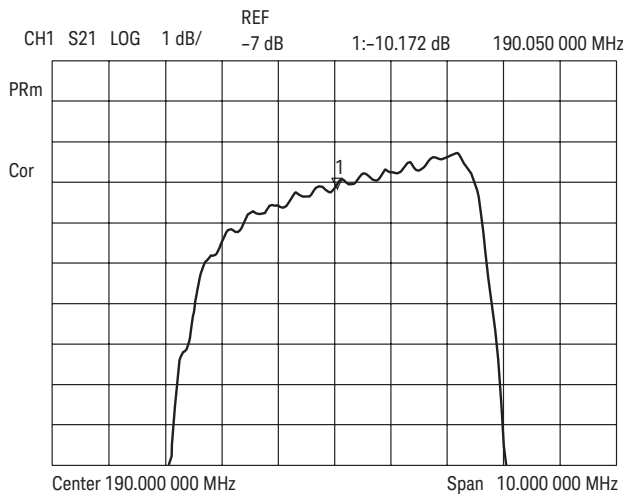

Figure 28. Undesired Tilt and Ripple in the IF Filter

3.3 Table of Impairments Versus Parameters Affected

Table 2 shows the physical impairments encountered with digitally demodulated signals, and the parameters that these impairments affect.

The key to troubleshooting is to identify the impairments that could be causing signal degradation. Each of the different impairments uniquely affects the quality of a digitally demodulated signal. As the table indicates, the I/Q constellation is typically affected by physical impairments. Although the constellation diagram is a good indicator of problems, further analysis may be necessary to isolate the source of the error. EVM is a powerful signal analysis tool that can be scrutinized to pinpoint sources of interference in receiver tests. Frequency response and group delay measurements prove effective in the detection of filtering problems. Phase error analysis can detect sources of unwanted phase noise.

Strategic use of these analysis tools will enhance your ability to track down sources of error in your digital radio receiver designs. The ability to quickly locate design problems can greatly reduce product development and test verification times, and facilitate the type approval of receiver designs.

Table 2. Impairments Versus Parameters Affected

Physical Impairments	Parameters Affected
I/Q Gain Imbalance	I/Q Constellation (Figure 20)
I/Q Quadrature Errors	I/Q Constellation (Figure 21), Average EVM, Magnitude of the Error Vector versus Time, Error Vector Spectrum
I/Q Offsets	I/Q Constellation (Figure 22)
Interfering Tone or Spur	I/Q Constellation (Figure 23), Average EVM, Error Vector Spectrum (Figure 24)
Incorrect Symbol Rate	I/Q Constellation, Phase Error
Baseband Filtering Problems	I/Q Constellation, Average EVM, Magnitude of the Error Vector versus Time (Figures 26 and 27)
IF Filter Tilt or Ripple	I/Q Constellation, Magnitude of the Error Vector versus Time, Frequency Response (Figure 28), Group Delay

4. Summary

Digital RF communications receivers are challenging to design, test, and troubleshoot. Two digital radio receiver designs were discussed in this application note: I/Q demodulator and sampled IF. Receivers must meet strict conformance standards. Common in-channel and out-of-channel tests verify that receiver designs meet these standards. To reduce measurement errors, best practices should be followed, with an awareness of measurement caveats. A basic troubleshooting procedure helps to isolate design problems. Application of these testing and troubleshooting techniques can reduce product cycle times and increase confidence in proper operation after the receiver is manufactured and put into use.

5. Appendix: From Bit Error Rate (BER) to Error Vector Magnitude (EVM)

Error Vector Magnitude (EVM) BER is the best measurement to verify receiver performance, but BER testing is not always possible in the subsystems of a digital radio receiver. Also, BER can indicate a problem exists, but it may not help identify the source of the problem. An alternative to BER testing is to examine the quality of a demodulated signal. The most widely used modulation quality metric in digital RF communications systems is the EVM. EVM provides a way to quantify the errors in digital demodulation and is sensitive to any signal impairment that affects the magnitude and phase trajectory of a demodulated signal.

As shown in Figure 29, the error vector is the vector difference between the reference signal and the measured signal. The error vector is a complex quantity that contains a magnitude and phase component. Expressed another way, the error vector is the residual noise and distortion remaining after an ideal version of the signal has been stripped away. EVM is the root-mean-square (rms) value of the error vector over time at the instants of the symbol clock transitions. By convention, EVM is usually normalized to the outermost symbol magnitude at the symbol times and expressed as a percentage:

$$\text{EVM} = (\text{rms error vector} / \text{outermost symbol magnitude}) \times 100\%$$

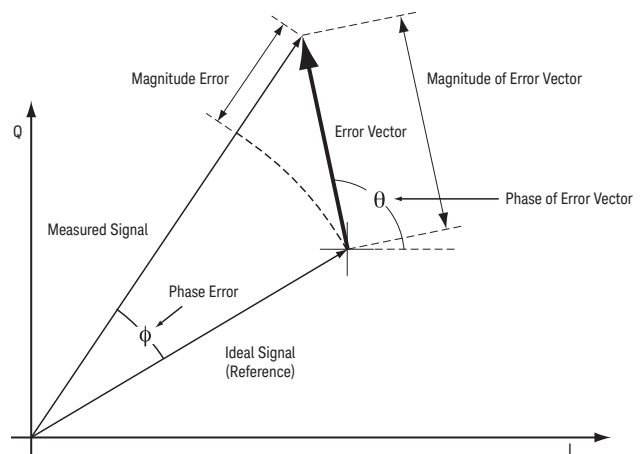

Figure 29. EVM and Related Quantities

The error vector information of the trajectory between the points (viewable in the magnitude of the error vector versus time display of the 89441A VSA) helps you troubleshoot baseband filtering problems in your receiver design (see section 3.2.4). Also, the spectrum of the error vector can help you locate sources of interference (see section 3.2.2). The magnitude error and phase error between the two vectors provide a way to view unwanted phase and amplitude modulation that may occur in your receiver.

EVM may also be normalized to the square root of the average symbol power. In this way, EVM can be related to the SNR:

$$\text{SNR} = -20 * \log (\text{EVM} / 100\%)$$

The importance of the above equation is that it relates EVM to BER through the SNR.

Many textbooks have standard curves that relate BER to SNR, as in Figure 30⁸. Generally, these curves assume that the noise is Additive White Gaussian Noise (AWGN) with a finite peak-to-average ratio, or crest factor. The assumptions made in generating textbook plots of BER versus SNR will not necessarily apply to a particular receiver. The noise in a receiver under test, for example, may not be AWGN but may instead have a strong spectral component. In addition, the steep slope of BER curves makes BER estimations from measured SNR (or EVM) more prone to error.

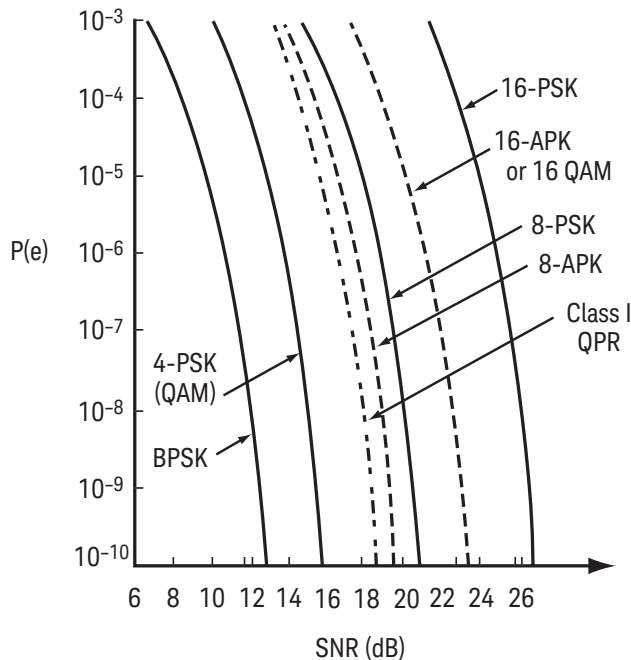

Figure 30. Probability of Error Versus SNR

However, EVM provides an easily measured figure-of-merit that can be used to monitor design changes, locate design problems and, when baselined against a BER measurement, indicate the likelihood that a design will meet the required specifications. Hence, the connection of BER to EVM is through the SNR, the more general indicator of likely signal quality (see Figure 31).

Measurements of EVM and related quantities can provide powerful insight into the performance of a digital radio receiver. When properly applied, these signal quality measurements can pinpoint sources of error by identifying the exact type of degradation in a signal. For more detail on using EVM measurements to analyze and troubleshoot vector-modulated signals, see Keysight Application Notes *Using Vector Modulation Analysis in the Integration, Troubleshooting, and Design of Digital RF Communications Systems*⁴ and *Ten Steps to a Perfect Digital Demodulation Measurement*⁵.

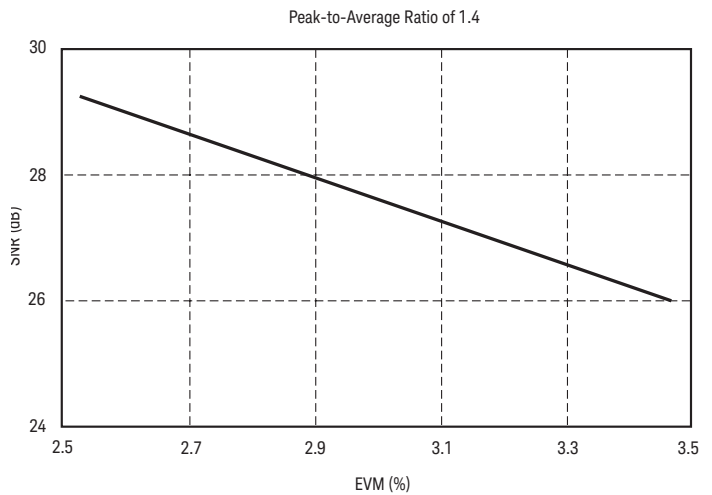

Figure 31. SNR Versus EVM for Crest Factor of 1.4

6. Symbols and Acronyms

α	Alpha (roll-off factor) of a Nyquist filter
ACP	Adjacent Channel Power
ADC	Analog-to-Digital Converter
AGC	Automatic Gain Control
ALC	Automatic Level Control
ASIC	Application-Specific Integrated Circuit
AWGN	Additive White Gaussian Noise
BER	Bit Error Rate
BERT	Bit Error Rate Tester
BT	Bandwidth-Time product (roll-off factor) of a Gaussian filter
CDMA	Code Division Multiple Access
CW	Continuous Wave
DDC	Digital Down Converter
DSP	Digital Signal Processor
DUT	Device Under Test
ETSI	European Telecommunications Standard Institute
EVM	Error Vector Magnitude
FER	Frame Erasure Rate
FFT	Fast Fourier Transform
GSM	Global System for Mobile communications
I	In-phase
IC	Integrated Circuit
IF	Intermediate Frequency
ISI	Inter-Symbol Interference
ITU	International Telecommunications Union
LNA	Low-Noise Amplifier
LO	Local Oscillator
NADC	North American Digital Cellular
PDC	Pacific Digital Cellular
PHS	Personal Handyphone System
PRBS	Pseudo-Random Binary Sequence
Q	Quadrature-phase
RBER	Residual Bit Error Rate
RF	Radio Frequency
SMR	Specialized Mobile Radio
SAW	Surface Acoustic Wave
SNR	Signal-to-Noise Ratio
TDMA	Time Division Multiple Access
TIA	Telecommunications Industry Association
TOI	Third-Order Intercept
UUT	Unit Under Test
VNA	Vector Network Analyzer
VSA	Vector Signal Analyzer

7. References

- 1 *Testing and Troubleshooting Digital RF Communications Transmitter Designs*, Keysight Application Note 1313, literature number 5968-3578E.
- 2 *Digital Modulation in Communications Systems—An Introduction*, Keysight Application Note 1298, literature number 5965-7160E.
- 3 *Measuring Bit Error Rate using the Keysight ESG-D Series RF Signal Generators Option UN7*, Application Note literature # 5966-4098E.
- 4 *Using Vector Modulation Analysis in the Integration, Troubleshooting, and Design of Digital RF Communications Systems*, Keysight Application Note 89400-8, literature number 5091-8687E.
- 5 *Ten Steps to a Perfect Digital Demodulation Measurement*, Keysight Application Note 89400-14A, literature number 5966-0444E.
- 6 *Fundamentals of RF and Microwave Noise Figure Measurements*, Keysight Application Note 57-1, literature number 5952-8255.
- 7 *Measuring Third-Order Intermodulation, N dB Bandwidth, and Percent AM with Built-in Functions*, Keysight Application Note 8590-8, literature number 5091-4052E.
- 8 K. Feher, *Digital Communications*, Prentice Hall 1981: Englewood Cliffs, New Jersey.
- 9 Theodore S. Rappaport, *Wireless Communications: Principles and Practices*, Prentice Hall 1996: Upper Saddle River, New Jersey.
- 10 Bernard Sklar, *Rayleigh Fading Channels in Mobile Digital Communication Systems Part I: Characterization*, IEEE Communications Magazine, July 1997, Vol. 35 No. 7.
- 11 Robert H. Walden, *Performance Trends for Analog-to-Digital Converters*, IEEE Communications Magazine, February 1999, Vol. 37 No. 2.

myKeysight

myKeysight

www.keysight.com/find/mykeysight

A personalized view into the information most relevant to you.



www.axiestandard.org

AdvancedTCA[®] Extensions for Instrumentation and Test (AXIe) is an open standard that extends the AdvancedTCA for general purpose and semiconductor test. Keysight is a founding member of the AXIe consortium. ATCA[®], AdvancedTCA[®], and the ATCA logo are registered US trademarks of the PCI Industrial Computer Manufacturers Group.



www.lxistandard.org

LAN eXtensions for Instruments puts the power of Ethernet and the Web inside your test systems. Keysight is a founding member of the LXI consortium.



www.pxisa.org

PCI eXtensions for Instrumentation (PXI) modular instrumentation delivers a rugged, PC-based high-performance measurement and automation system.



Three-Year Warranty

www.keysight.com/find/ThreeYearWarranty

Keysight's commitment to superior product quality and lower total cost of ownership. The only test and measurement company with three-year warranty standard on all instruments, worldwide.



Keysight Assurance Plans

www.keysight.com/find/AssurancePlans

Up to five years of protection and no budgetary surprises to ensure your instruments are operating to specification so you can rely on accurate measurements.



www.keysight.com/go/quality

Keysight Technologies, Inc.
DEKRA Certified ISO 9001:2008
Quality Management System

Keysight Channel Partners

www.keysight.com/find/channelpartners

Get the best of both worlds: Keysight's measurement expertise and product breadth, combined with channel partner convenience.

This document was formerly known as application note 1314.

www.keysight.com/find/assist

For more information on Keysight Technologies' products, applications or services, please contact your local Keysight office. The complete list is available at: www.keysight.com/find/contactus

Americas

Canada	(877) 894 4414
Brazil	55 11 3351 7010
Mexico	001 800 254 2440
United States	(800) 829 4444

Asia Pacific

Australia	1 800 629 485
China	800 810 0189
Hong Kong	800 938 693
India	1 800 112 929
Japan	0120 (421) 345
Korea	080 769 0800
Malaysia	1 800 888 848
Singapore	1 800 375 8100
Taiwan	0800 047 866
Other AP Countries	(65) 6375 8100

Europe & Middle East

Austria	0800 001122
Belgium	0800 58580
Finland	0800 523252
France	0805 980333
Germany	0800 6270999
Ireland	1800 832700
Israel	1 809 343051
Italy	800 599100
Luxembourg	+32 800 58580
Netherlands	0800 0233200
Russia	8800 5009286
Spain	0800 000154
Sweden	0200 882255
Switzerland	0800 805353
	Opt. 1 (DE)
	Opt. 2 (FR)
	Opt. 3 (IT)
United Kingdom	0800 0260637

For other unlisted countries:
www.keysight.com/find/contactus
(BP-09-04-14)

