

Keysight Technologies

Concepts of High Speed Downlink Packet Access: Bringing Increased Throughput and Efficiency to W-CDMA

Application Note

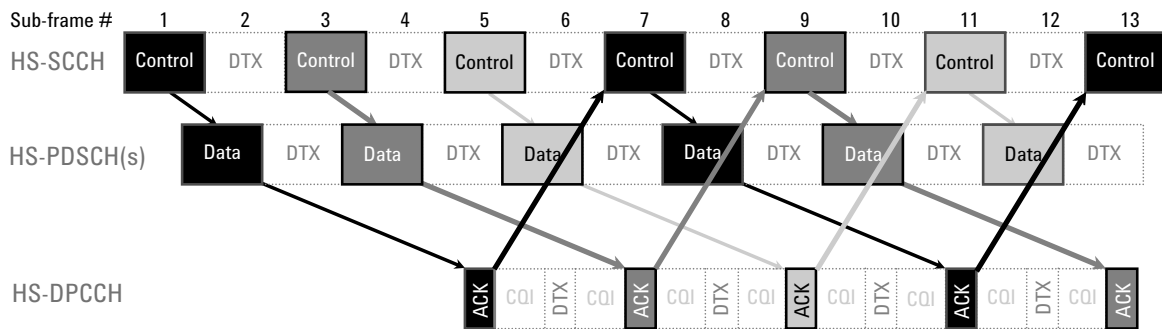



Introduction

The wideband-CDMA (W-CDMA) specifications are the most ambitious and complex radio standards ever written. Thus it comes as no surprise that new features are being continuously added to improve W-CDMA system performance.

One of the most significant additions to the W-CDMA specifications is the incorporation of high speed downlink packet access (HSDPA). Standardization of this new technology began in 2002 in W-CDMA Release 5. HSDPA increases downlink peak data rates and packet data efficiency, making the system more competitive with other high data rate wireless technologies in use today, such as 1xEV-DO.

This application note discusses the major changes that HSDPA introduces in the W-CDMA physical and transport layers, including new link adaptation techniques and modifications to the structure of the physical channels, modulation, and coding.

Also included is a brief overview of the Keysight Technologies, Inc. products that can be used to design and test W-CDMA base stations (BTS) and user equipment (UE) that incorporate HSDPA.

You can find additional information about W-CDMA and other 3G technologies at www.keysight.com/find/3g.

Table of Contents

HSDPA Concepts.....	4
Changes introduced by HSDPA	4
HSDPA frame structure	5
New channels	5
Downlink physical channel structure: HS-PDSCH.....	6
Modulation schemes for HS-PDSCH.....	7
Downlink transport channel coding.....	8
Example of channel coding.....	9
Downlink physical channel structure: HS-SCCH	10
Downlink physical channel timing	11
Use of CDM and TDM in the downlink.....	11
Uplink physical channel structure	12
Uplink spreading and scrambling.....	13
Radio frame timing of downlink and uplink physical channels.....	14
Transparent versus non-transparent data services.....	14
Adaptive modulation and coding.....	15
Effective code rate and nominal data rate	16
Maximum data rate	16
Hybrid ARQ	17
HARQ re-transmission.....	17
Use of incremental redundancy	18
Inter-TTI interval	19
HARQ processes	19
MAC layer packet-scheduling functionality	21
HSDPA test models and reference channels.....	21
What comes next?.....	22
Keysight Solutions for HSDPA Design and Testing	23
Design simulation and verification using dynamically linked solutions.....	23
Baseband design simulation and verification.....	24
ADS W-CDMA design library	24
ESG with Signal Studio for HSDPA over W-CDMA	25
HSDPA personality for signal analyzers	27
Manufacturing test solutions: HSDPA test application for the 8960 series test set.....	28
Power supplies and software for battery-drain analysis.....	29
Pre-conformance and conformance RF test solutions.....	30
Development, conformance, and interoperability signaling test solutions....	32
Summary.....	33
References	33

HSDPA Concepts

W-CDMA technology, which provides the air interface for UMTS, the 3G system defined by the 3GPP (Third Generation Partnership Project), can in perfect conditions deliver peak data rates of up to 2 Mbps. But in typical network deployment, a cell will have a maximum capacity of around 1 Mbps shared between the cell's users. Peak user data rates are limited to 384 kbps.

Release 5 of the 3GPP W-CDMA specification adds HSDPA in an effort to make the system more efficient for packet data applications by increasing peak data rates and reducing packet latency. Although the theoretical peak data rate for HSDPA is approximately 14 Mbps, the actual rates achieved will be much lower than that. The performance of HSDPA depends largely on the cell size. In macro cell applications, HSDPA may improve on W-CDMA data capacity only by perhaps 30 percent, with sustainable peak data rates for one user of maybe 1 Mbps. But in micro and pico cell deployments where co-channel interference is minimal, HSDPA is capable of delivering much higher performance over basic W-CDMA. The exact improvement is very hard to predict since it depends on actual channel conditions and the real-time capabilities of the BTS – neither of which are standardized. However, some credible estimates for Release 5 suggest a cell capacity of up to 3 Mbps rising to 5 Mbps in Release 6, which includes a more advanced UE receiver and improved BTS packet scheduling. Peak user data rates might reach 3.6 Mbps for short periods of time but are unlikely to be sustainable.

HSDPA technology is backwards-compatible with 3GPP Release 99, so voice and data applications developed for W-CDMA can still run on the upgraded networks, and the same radio channel will support W-CDMA and HSDPA services simultaneously.

The result of adding HSDPA to W-CDMA is similar to that of adding E-GPRS to GSM: that is, the improvement in peak data rates and the overall increase in system capacity, particularly in small cells. Network operators are pushing for quick adoption of HSDPA, which means that design and test engineers require suitable test equipment to enable them to develop and test new HSDPA features in the BTS and UE.

Changes introduced by HSDPA

To improve W-CDMA system performance, HSDPA makes a number of changes to the radio interface, which mainly affect the physical and transport layers:

- Shorter radio frame
- New high-speed downlink channels
- Use of 16QAM modulation in addition to QPSK modulation
- Code multiplexing combined with time multiplexing
- A new uplink control channel
- Fast link adaptation using adaptive modulation and coding (AMC)
- Use of hybrid automatic-repeat-request (HARQ)
- Medium access control (MAC) scheduling function moved to Node B

Because this application note focuses on the physical layer aspects of HSDPA, the MAC functionality is covered only briefly.

HSDPA frame structure

The HSDPA radio frame (actually a sub-frame in the W-CDMA architecture) is 2 ms in length—equivalent to three of the currently defined W-CDMA slots. There are five HSDPA sub-frames in a 10 ms W-CDMA frame, as shown in Figure 1. The shorter frame size allows user data transmissions to be assigned to one or more physical channels for a shorter duration, thus allowing the network to readjust its resource allocation in time as well as in the code domain.

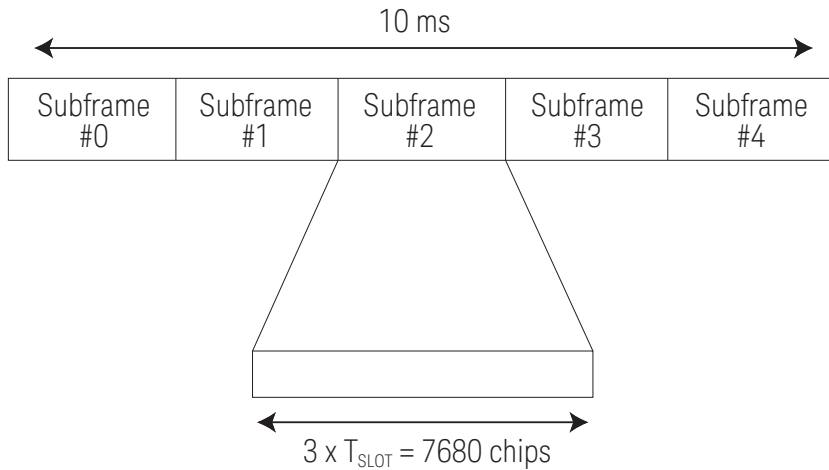

Figure 1. There are five HSDPA sub-frames in a 10 ms W-CDMA frame

New channels

HSDPA introduces new physical channels and a new transport channel to W-CDMA.

Two new types of physical channel are added to the downlink:

- A high speed physical downlink shared channel (HS-PDSCH) that carries the payload data
- A high speed shared control channel (HS-SCCH) that carries the UE identity and channel parameters of the associated HS-PDSCH(s)

A new transport channel, the high speed downlink shared channel (HS-DSCH), is also added in the downlink.

HSDPA adds one new uplink physical channel, the high speed dedicated physical control channel (HS-DPCCH), for carrying the HARQ acknowledge (ACK) and channel quality indicator (CQI) information.

With these enhancements, Layer 2 (the MAC layer) can map existing W-CDMA logical channels (DCCH and DTCH) onto the high-speed transport channel (HS-DSCH). Layer 1 in turn maps the transport channel (HS-DSCH) onto one or more physical channels (HS-PDSCH), up to 15. The physical layer then creates the HS-SCCH and HS-DPCCH to control and assist with HS-DSCH transmission.

Downlink physical channel structure: HS-PDSCH

The HS-PDSCH is used to carry the HS-DSCH. As shown in Figure 2, it occupies a 2 ms sub-frame. Two slot formats (bit rates) are possible, based on the type of modulation used.

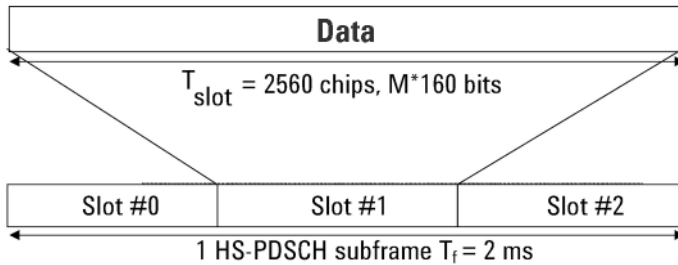

M is the number of bits per modulation symbol i.e. M=2 for QPSK and M=4 for 16 QAM.

Slot format #i	Channel bit rate (kb/s)	Channel symbol rate (ks/s)	SF	Bits/HS-DSCH subframe	Bits/slot
0(QPSK)	480	240	16	960	320
1(16QAM)	960	240	16	1920	640

Figure 2. Structure of the HS-PDSCH (Ref: 3GPP TS 25.211 5.3.3.13)¹

Each HS-PDSCH is assigned one channelization code of a fixed spreading factor of 16 (SF = 16) from the set of channelization codes reserved for HS-DSCH transmission. The HS-PDSCH code number is configurable. Because HSDPA technology allows multi-code transmission, a UE may be assigned multiple channelization codes (multiple HS-PDSCHs) in the same HS-PDSCH subframe, to the extent of the UE's capability.

The symbol rate of the HS-PDSCH is fixed at 240 ksps, but the code number is variable. An HS-PDSCH may use quadrature phase shift keying (QPSK) modulation or 16 quadrature amplitude modulation (QAM), so its channel bit rate can vary (480 kbps or 960 kbps) based on its modulation scheme (QPSK or 16QAM). The channel bit rate corresponds to the data rate after coding is applied. Originally, 8PSK and 64QAM were considered for use in HSDPA, but they are not part of the Release 5 specifications.

The HS-PDSCH itself does not carry any Layer 1 information. All relevant Layer 1 information is transmitted in the associated HS-SCCH.

1. Figure references here and throughout this application note relate to 3GPP Release 5 specifications. For complete titles, please see the References section at the end of this document.

Modulation schemes for HS-PDSCH

The HS-PDSCH is modulated, spread, scrambled, and summed as are other W-CDMA downlink physical channels. The only difference is that the modulation mapping in the HS-PDSCH can represent either QPSK or 16QAM modulation, and the SF is always fixed at 16. The IQ constellation in Figure 3 shows the correspondence of symbols to bits, as described in the specifications.

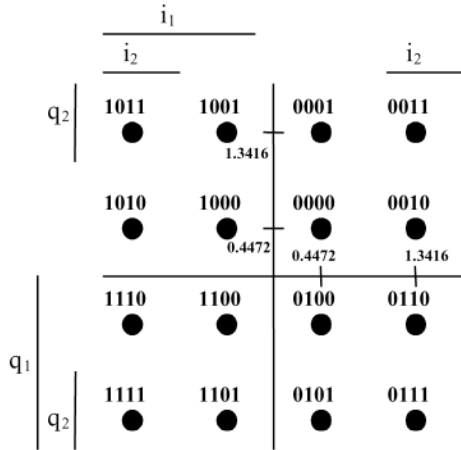

Figure 3. IQ constellation shows the correspondence of symbols to bits (Ref: 3GPP TS 25.213 5.1)

The code domain displays for two signals, each with four assigned HS-PDSCHs, are shown in Figure 4. The signal on the left uses 16QAM modulation and the signal on the right uses QPSK modulation. The constellation display for one HS-PDSCH of each signal type is also presented.

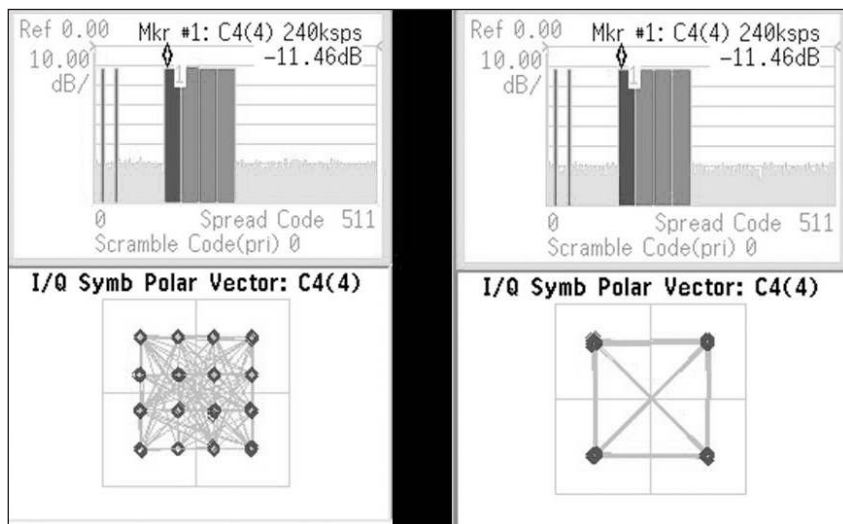

Figure 4. Code domain displays for 16QAM (left) and QPSK (right) modulated signals

Downlink transport channel coding

The HS-DSCH is evolved from the downlink shared channel (DSCH) introduced in W-CDMA Release 99 to enable time-multiplexing of different user transmissions. To obtain higher data rates and greater spectral efficiency, the fast power control and variable spreading factor of the DSCH are replaced in Release 5 by short packet size, multi-code operation, and techniques such as AMC and HARQ on the HS-DSCH.

The coding blocks for the HS-DSCH are shown in Figure 5. The channel coding is always 1/3 rate (for every bit that goes into the coder, three bits come out), based on the Release 99 1/3 turbo encoder. The effective code rate varies, however, depending on the parameters applied during the two-stage HARQ rate-matching process.

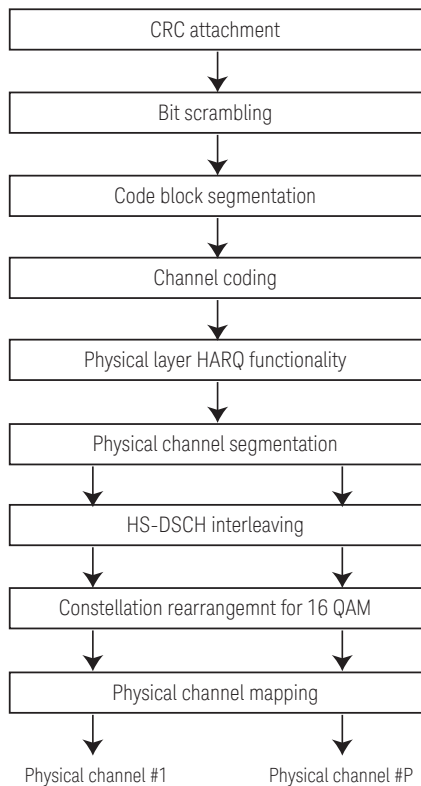

Figure 5. Downlink transport channel coding process (Ref: 3GPP TS 25.212 4.5)

During this process, the number of bits at the output of the channel coder are matched to the total number of bits of the HS-PDSCH set to which the HS-DSCH is mapped. The HARQ functionality is controlled by the redundancy version (RV) parameter. This parameter essentially defines the puncturing scheme. The exact set of bits at the output depends on the number of input bits, the number of output bits, and the RV parameter.

Physical channel segmentation divides the bits among the different physical channels when more than one HS-PDSCH is used. Interleaving is done separately for each physical channel.

As noted previously, HSDPA uses both QPSK modulation (the technique specified in W-CDMA) and 16QAM. The latter technique is preferred when radio conditions are good. Constellation rearrangement applies only to 16QAM modulation, in which two of the four bits in a symbol have a higher probability of error than the other two bits. The rearrangement occurs during re-transmission and disperses the error probability equally among all the bits in the average, after the re-transmission combining.

Example of channel coding

An example HS-DSCH channel coding is shown in Figure 6. The coding corresponds to a fixed reference channel (FRC H-Set 4) that is used for testing the UE receiver. The first rate-matching stage matches the number of input bits to a virtual incremental redundancy (IR) buffer. The second rate-matching stage matches the resulting number of bits to the number of physical channel bits available in the HS-PDSCH set during the transmission time interval (TTI). This stage is controlled by the RV parameter. Rate-matching involves data puncturing, so each RV parameter defines a different puncturing scheme.

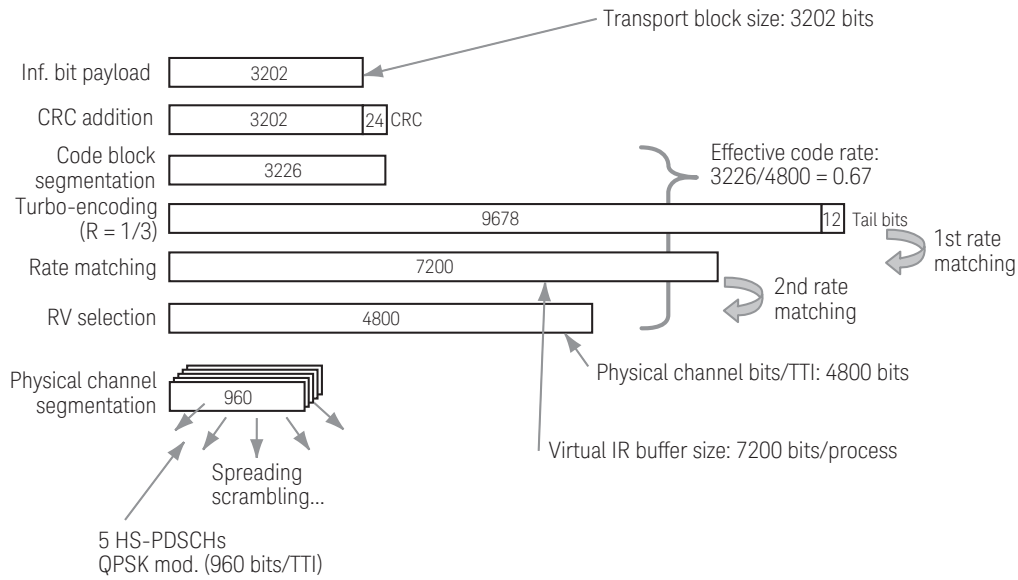

Figure 6. Channel coding example (Ref: 3GPP TS 25.101 A.7.1.4)

The number of HS-PDSCHs (five in this example) and the modulation format define the number of physical channel bits after RV selection (960 bits for QPSK modulation x 5 = 4800 bits). The turbo-encoding code rate is fixed at 1/3, but the effective code rate is the combination of turbo-encoding and the rate matching stages. The effective code rate for any HS-DSCH configuration thus can be calculated if the transport block size, the number of HS-PDSCH's, and the modulation format are known. In this case the effective code rate is 0.67, or $(3202 + 24) \text{ bits} / (960 \text{ bits} \times 5)$.

Downlink physical channel structure: HS-SCCH

The HS-SCCH carries signaling information related to the HS-DSCH transport channel transmission. The HS-SCCH bit rate is fixed at 60 kbps, but its code number is configurable. A basestation (BTS) can transmit four or more HS-SCCHs, to a maximum of 32 per cell. Each UE monitors up to four of these channels (known as the HS-SCCH set) simultaneously.

The HS-SCCH is spread and summed as are other downlink physical channels.

Figure 7 illustrates the physical channel structure of the HS-SCCH. The first slot carries critical information for HS-PDSCH reception, such as the channelization code set (7 bits) and the modulation scheme (1 bit). After receiving the first slot, the UE has just one time slot for decoding the information and preparing to receive the HS-PDSCH.

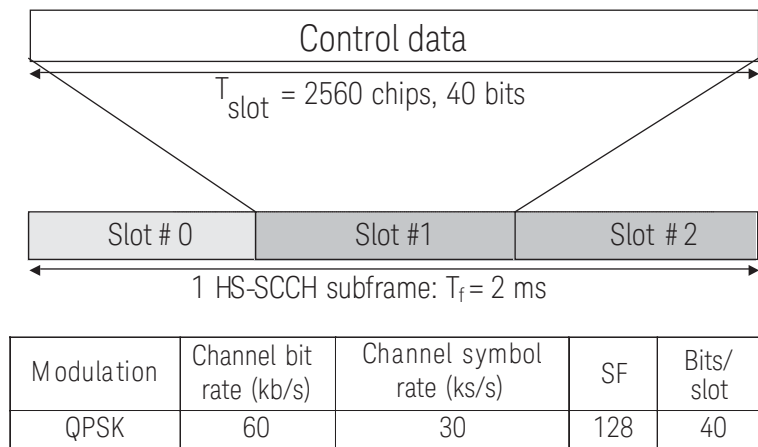

Figure 7. Structure of the HS-SCCH (Ref: 3GPP TS 25.212 4.6)

The number of HS-PDSCHs (or code channels) that map onto a single HS-DSCH can vary dynamically between 1 and 15. Orthogonal variable spreading factor (OVSF) codes are used. The number of multi-codes and the corresponding offset for the HS-PDSCH's mapped from a given HS-DSCH are signaled on the HS-SCCH. The multi-codes (P) at offset (O) are allocated as follows: Cch, 16, $O \dots$ Cch, 16, $O+P-1$.

The second and third slots carry the HS-DSCH channel coding information, such as the transport block size (6 bits), HARQ information (3 bits), the redundancy and constellation version (3 bits), and the new data indicator (1 bit). The data of the three slots are covered with the 16-bit UE identity.

Downlink physical channel timing

Figure 8 illustrates how a BTS sends control information associated with an HS-PDSCH subframe—for example, the modulation scheme—on an HS-SCCH subframe.

The BTS transmits two slots (or 5,120 chips) of the HS-SCCH subframe before it begins transmitting the HS-PDSCH. The HS-SCCH and HS-PDSCH thus overlap during a slot (the third slot of the HS-SCCH).

Information pertaining to the demodulation of the HS-PDSCH subframe must be transmitted at the beginning of the HS-SCCH subframe, and the UE must quickly decode the HS-SCCH, so that that UE does not miss the HS-PDSCH.

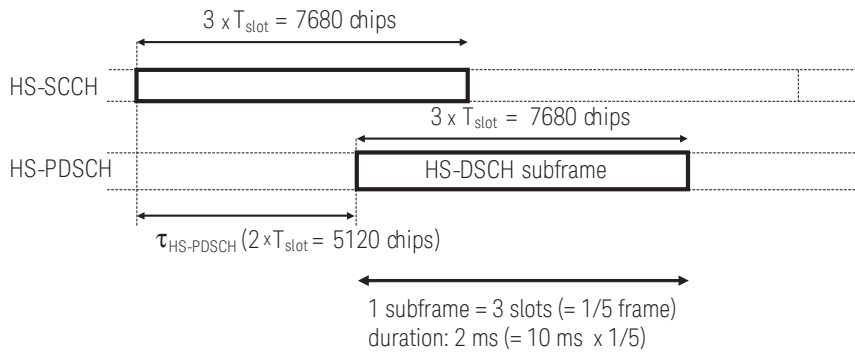

Figure 8. Timing of the downlink physical channels (Ref: 3GPP TS 25.211 7.8)

Use of CDM and TDM in the downlink

As noted earlier, both code domain multiplexing (CDM) and time domain multiplexing (TDM) are used in HSDPA.

As shown in Figure 10, multiple UEs can receive information in the same subframe by using different parts of the orthogonal variable spreading factor (OVSF) code space.

The main difference between a dedicated channel such as the DPCH used in W-CDMA Release 99 and a shared packet channel such as the HS-PDSCH used in HSDPA is that the shared packet channel can also multiplex several users in the time domain.

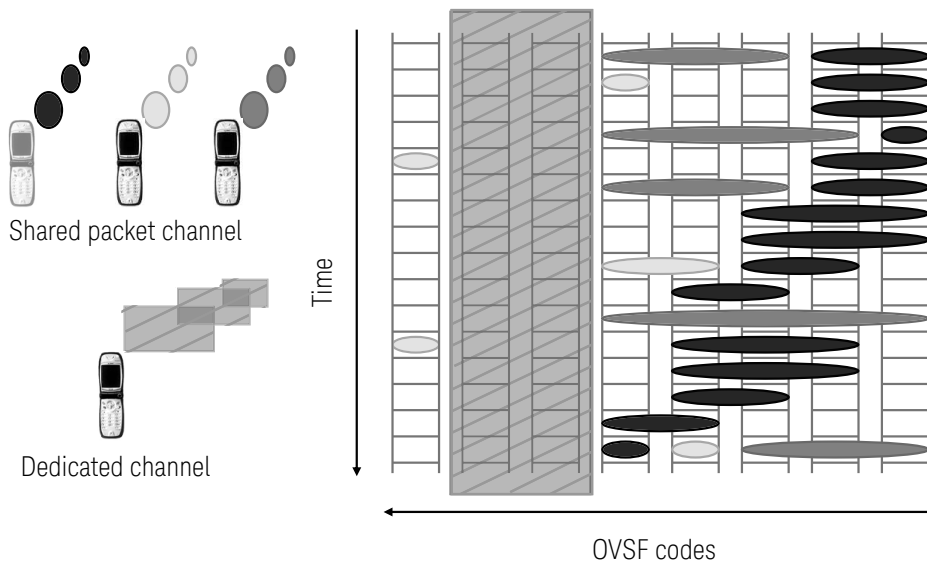
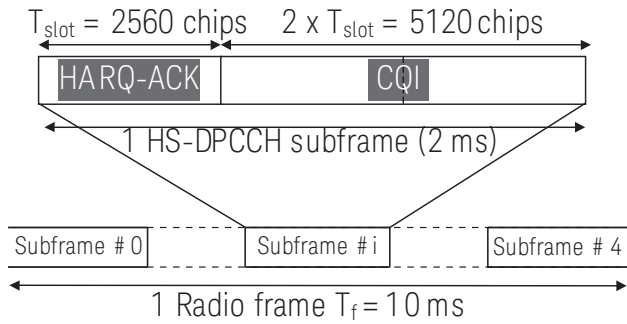

Figure 9. Downlink code and time multiplexing

Uplink physical channel structure

The HS-DPCCH carries uplink feedback signaling related to the downlink HS-DSCH transmission. This signaling consists of HARQ acknowledgement (HARQ-ACK) and channel-quality indication (CQI), shown in Figure 10. Each 2 ms sub-frame—like those of the downlink physical channels—consists of 3 slots, each slot of 2,560 chips. The HARQ-ACK is carried in the first slot of the HS-DPCCH sub-frame, and the CQI in the second and third slots.



Slot format #i	Channel bit rate (kb/s)	Channel symbol rate (ks/s)	SF	Bits/subframe	Bits/slot	Transmitted slots per subframe
0	15	15	256	30	10	3

Figure 10. Structure of the HS-DPCCH (Ref: 3GPP TS 25.211 5.2.1)

There is at most one HS-DPCCH on each radio link. The HS-DPCCH can exist only in association with a W-CDMA uplink DPCCH.

Two different paths are used for HARQ-ACK and CQI coding. The HARQ-ACK information (1 bit) is coded to 10 bits, with ACK coded as 1, and NACK coded as 0. The CQI information is coded using a (20,5) code. The coded bits are mapped directly to the HS-DPCCH.

The feedback cycle of the CQI can be set as a network parameter in predefined steps from 2 ms to infinity (disabled). Note that an active HS-DPCCH may have slots in which no HARQ-ACK or CQI information is transmitted. The HS-DPCCH is thus a bursted channel.

Uplink spreading and scrambling

Figure 11 illustrates the process that enables uplink spreading and scrambling.

There are two possible HS-DPCCH positions on the IQ summation block. If the number of DPDCHs used in transmission is even, the HS-DPCCH takes the path of I-summation. If the number of DPDCHs is odd, the HS-DPCCH takes the Q-summation path.

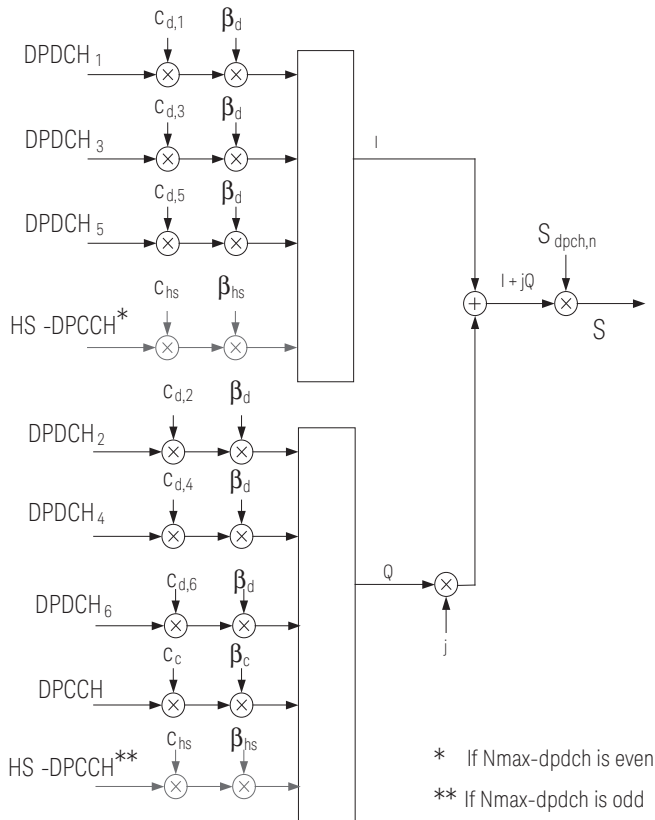

Figure 11. I and Q summations for HS-DPCCH (Ref: 3GPP 25.213 4.2.1)

In order to balance the total power on the I and Q axes, the HS-DPCCH channelization code varies according to the activity status of the DPDCH channel. As Table 1 shows, for example, when one DPDCH only is being used, the HS-DPCCH is on the Q path with a channelization code of 64. When three DPDCHs are used, the HS-DPCCH is on the I path with a code of 32.

Table 1. HS-DPCCH channelization code (Ref: 3GPP TS 25.213 4.3.1.2)

Channelization code of HS-DPCCH	
$N_{max-dpdch}$	Channelization code C_{ch}
1	$C_{ch,256,64}$
2, 4, 6	$C_{ch,256,1}$
3, 5	$C_{ch,256,2}$

The power level of the HS-DPCCH is established as an offset to the uplink DPCCH. The β_{hs} value is derived from the power offsets of the HARQ-ACK and CQI fields, which are signalled by the higher layers.

Radio frame timing of downlink and uplink physical channels

The radio frame timing for the downlink and uplink physical channels is shown in Figure 12. The HS-SCCH subframe 0 aligns with the W-CDMA 10 ms radio frame.

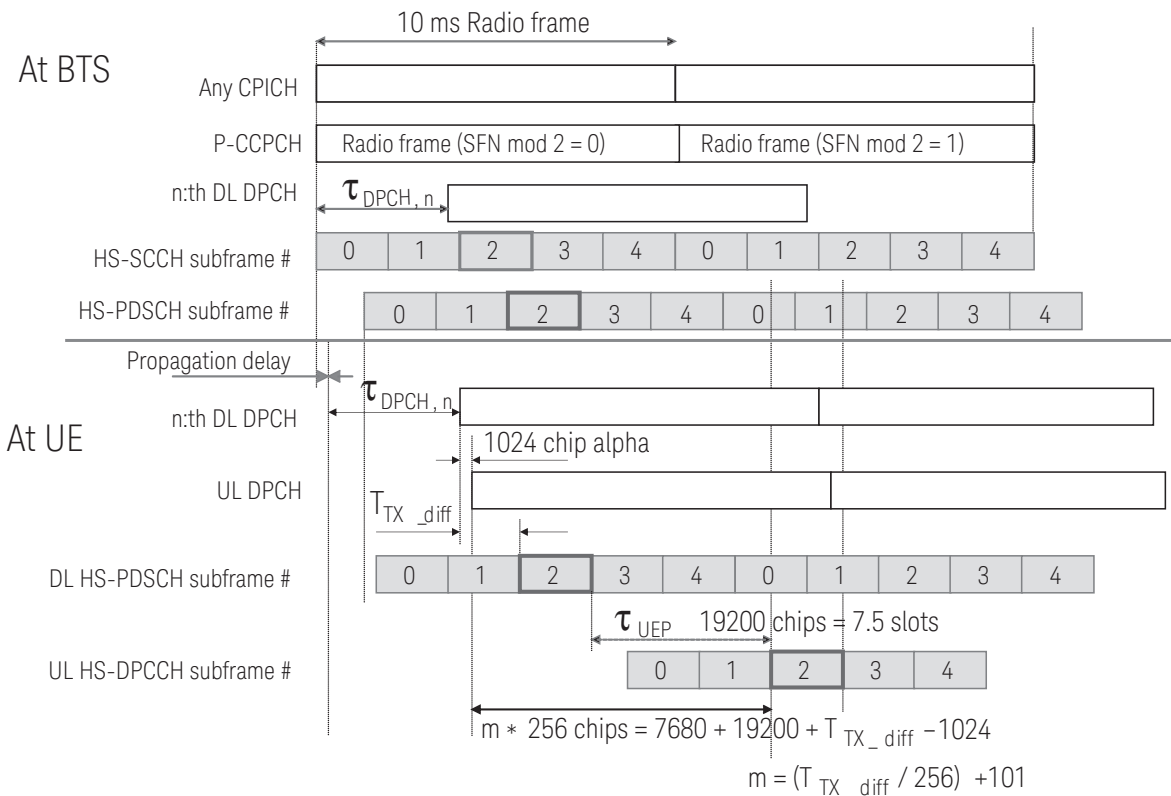

Figure 12. Timing of the downlink and uplink physical channels (Ref: 3GPP TS 25.211 7.7 and 7.8)

The HS-DPCCH is transmitted approximately 7.5 slots (19,200 chips) after its corresponding downlink HS-PDSCH subframe. The timing of the ACK/NACK response from the UE on the HS-DPCCH is defined explicitly, so that the BTS will know when to expect the response for each sub-frame it has transmitted.

The HS-DPCCH transmission time is referenced to the uplink DPCH and to the transmit time difference between the downlink DPCH and the subframe of interest.

The overall time from the beginning of the downlink HS-PDSCH subframe until the beginning of the uplink HS-DPCCH subframe is somewhat greater than three subframes.

This downlink and uplink timing information will be considered again later in this application note in reference to the HARQ processes.

Transparent versus non-transparent data services

In wireless communications, there are two main types of data transmission

- Transparent—constant rate, variable errors (no re-transmissions)
- Non-transparent—variable rate, zero errors (re-transmissions)

HSDPA uses non-transparent data transmission. Coding varies in real time. Throughput is unpredictable and depends on RF conditions. The goal is to transmit as much data as fast as possible using the least radio resources. Two different link adaptation techniques are used to achieve this goal: adaptive modulation and coding (AMC) and hybrid automatic repeat request (HARQ).

Adaptive modulation and coding

Link adaptation is one important way in which HSDPA improves data throughput. The technique used, AMC, varies the downlink modulation-coding scheme depending on the channel conditions for each user. The power of the transmitted signal is held constant over a sub-frame interval, and the modulation and coding format are changed to match the current received signal quality or channel conditions at the receiver. In this scenario, users close to the BTS are typically assigned higher order modulation with higher code rates (for example, 16QAM with an effective code rate of 0.89), but the modulation-order and code rate will decrease as the distance from the BTS increases. As mentioned earlier, 1/3 rate turbo coding is used and different effective code rates are obtained through various rate-matching parameters.

In HSDPA, the UE reports the channel conditions to the BTS via the uplink channel CQI field in the HS-DPCCH. The CQI value can be 0 to 30, with a value of 0 indicating “out-of-range.” Each CQI value corresponds to a certain transport block size, number of HS-PDSCHs, modulation format, reference power adjustment, virtual IR buffer size, and RV parameter for a certain UE category. See the examples in Table 2.

Table 2. Coding parameters from CQI table for UE Categories 1 to 6 (Ref: 3GPP TS 25.214 6A.2)

CQI Value	Transport block size	Number of HS-PDSCH	Modulation	Reference power adjustment Δ dB	N_{IR}^1	RV
0			Out of range			
1	137	1	QPSK	0	9600	0
15	3319	5	QPSK	0	9600	0
16	3565	5	16QAM	0	9600	0
30	7168	5	16QAM	-8	9600	0

1. N_{IR} is the virtual incremental redundancy buffer size per HARQ process

The UE reports the maximum CQI value whose corresponding parameters would theoretically provide an acceptable block error ratio (BLER) for the current link conditions.

The reported CQI value is then used by the BTS in combination with other parameters to determine the appropriate coding configuration for the next packet transmission to the UE. To fully define the coding configuration for a certain transmission, the BTS must select the following parameters:

- Transport block size (254 from which to choose)
- Modulation type—QPSK or 16QAM
- Number of physical downlink codes (1 to 15)
- Rate-matching parameters: virtual IR buffer size and RV (or data puncturing scheme)

So, even though there are a limited number of CQI values, there are literally thousands of configurations from which the BTS can choose for a certain transmission.

Effective code rate and nominal data rate

The transport block size, modulation type, and number of physical downlink codes determine the effective code rate as shown earlier in Figure 6. The nominal data rate can be directly calculated from the transport block size divided by the transmission time interval (TTI), which in HSDPA is fixed at 2 ms.

Therefore, in HSDPA many nominal data rates (or transport block sizes) are possible by varying the modulation type, effective code rate, and number of multicodes. These parameters can be adjusted every sub-frame (2 ms).

Maximum data rate

For example, the largest transport block size is 27,952 bits, which corresponds to the highest data rate of 13.976 Mbps (27,952 bits/2 ms = 13.976 Mbps). This data rate is obtained by using 16QAM, an effective code rate of 0.9714, and 15 HS-PDSCHs.

In real life, the 14 Mbps headline figure for HSDPA is not achievable. It is physically possible to configure such a channel but there is nowhere it could be used. The channel configuration requires close-to-perfect link conditions. In Figure 13, the code domain display that shows the 15 HS-PDSCHs with the 16QAM constellation display for one of the HS-PDSCHs illustrates that most of the cell's capacity would be consumed by this high data rate HS-DSCH configuration.

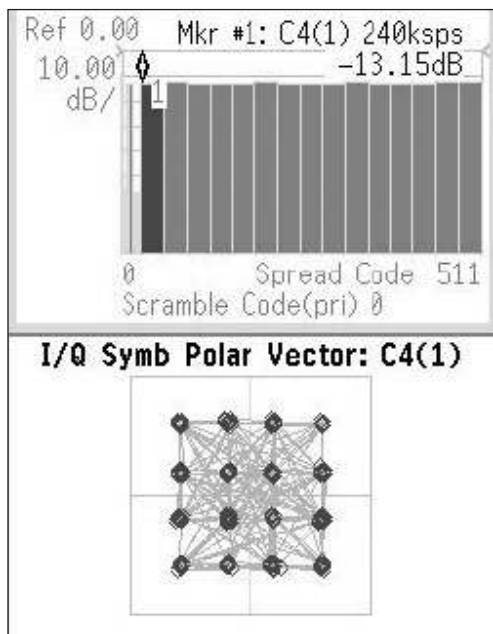

Figure 13. Code domain display of 15 HS-PDSCHs (top) and 16QAM constellation display of a single HS-PDSCH (bottom)

Realistic peak data rates are likely to be much lower than 14 Mbps. As an example, the most stringent “single link” conformance test requirement for the UE in Release 5 is based on a five-code QPSK channel with nominal data rate of 1.6 Mbps. The required throughput is 1.269 Mbps. The most stringent “closed loop diversity” conformance test requirement for the UE in Release 5 is based on a four-code 16QAM channel with nominal data rate of 2.332 Mbps. The required throughput in this case is 1.5 Mbps. In both these test cases the signal needs to be 10 dB above the noise and the UE consumes half the cell power.

Hybrid ARQ

Hybrid automatic repeat request (HARQ) is a technique combining feed-forward error correction (FEC) and ARQ methods that save information from previous failed attempts to be used in future decoding.

HARQ is an implicit link-adaptation technique. Whereas AMC uses explicit C/I or similar measurements to set the modulation and coding format, HARQ uses link-layer acknowledgements (ACK/NACK) for re-transmission decisions. Put another way, AMC provides the coarse data-rate selection, while HARQ provides fine data-rate adjustment based on channel conditions. See Figure 14.

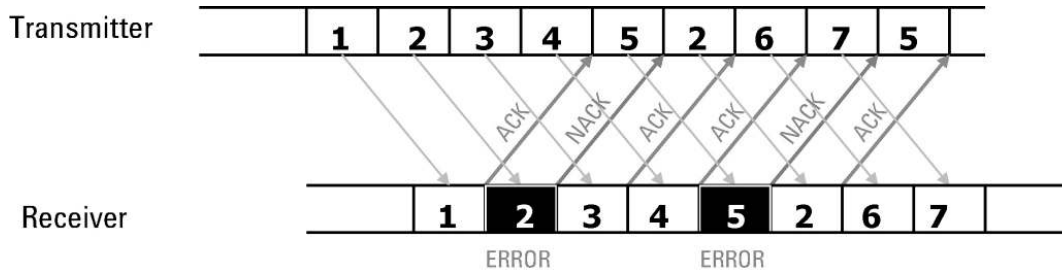

Figure 14. HARQ uses link-layer acknowledgments to make re-transmission decisions

HARQ re-transmission (Ref: 25.858 7.1)

For a re-transmission, HARQ uses the same transport-block set—and thus the same number of information bits—as were used in the initial transmission. However, it may use a different modulation scheme, channelization-code set—including the size of the channelization-code set—or transmission power.

As a result, the number of channel bits available for a re-transmission may differ from that of the initial transmission. (Channel bits are the bits actually transmitted over the air.) Moreover, even if the number of channel bits remains the same, the channel-bit set may be different.

To minimize the number of additional re-transmission requests, HARQ uses one of two “soft-combining” schemes to ensure proper message decoding:

- Chase combining (CC) involves sending an identical version of an erroneously detected packet; received copies are combined by the decoder prior to decoding
- Incremental redundancy (IR) involves sending a different set of bits incrementally to be combined with the original set, thus increasing the amount of redundant data and the likelihood of recovering from errors introduced on the air

Use of incremental redundancy

Figure 15 illustrates how the IR scheme works.

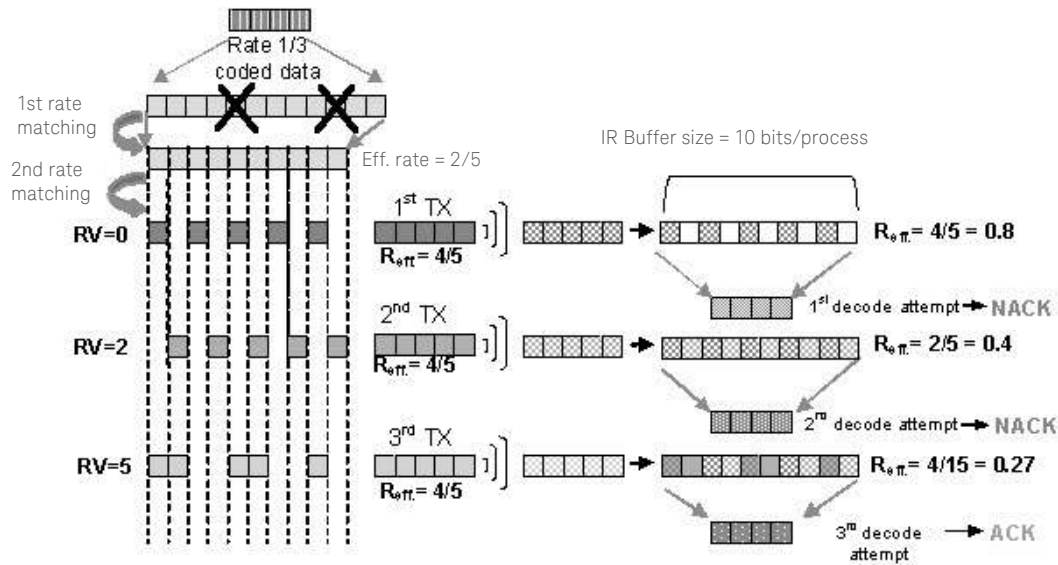

Figure 15. Use of incremental redundancy for HARQ re-transmission

For simplicity, a theoretical IR buffer size of 10 bits/process and a single process are assumed in this example. The original data (4 bits) corresponds to the data block after the CRC has been added. The data is encoded at the 1/3 rate, and it then gets punctured as part of the first rate-matching stage. At this stage the number of output bits are matched to the IR buffer size, which is 10 bits in this case.

The second rate-matching stage (redundancy version selection) punctures the data again. The data can be punctured into different data sets, each corresponding to a different RV. These are indicated here as three shades of gray—dark, medium, and light. Only one of these data sets will be sent in any given transmission.

The five dark gray bits (RV = 0) are sent on the air (OTA), resulting in an effective code rate of 4/5. That is, for every original data bit, 1 + 1/4 bits are transmitted OTA. The data arrives at the UE, is demodulated, is padded with dummy bits, and stuffed into the IR buffer. The data is then decoded, with some possibility of error, to provide the four striped (original data) bits shown at the top left in Figure 15. This block is checked against the CRC, and if it is found to be in error, it is stored and a NACK is sent to request a re-transmission.

When the re-transmission is sent, it employs a different RV or puncture scheme, and sends the five medium gray bits OTA. At the UE, the medium gray bits are recombined with the original transmission's dark gray bits to provide an effective code rate of 2/5. Now for every data bit there are 2 1/2 bits available for decoding, which increases the likelihood of success. However, when the results are checked against the CRC, if the block is still in error, the re-transmission process begins again.

Yet another RV or puncture scheme is used, appearing now as the light gray bits that are sent OTA and recombined at the UE with the dark and medium gray bits from the first and second transmission. Note that the new RV provides additional redundant data, even if some or all of the encoded bits are repetitions of encoded bits sent earlier. After the third transmission, the effective code rate is 4/15—for every data bit there are now 3 + 3/4 bits. The data is at last correctly decoded and an ACK is sent back. If the block were still in error, a NACK would be sent and still more RVs could be transmitted, depending on the maximum number of transmissions allowed for a block.

In the case of 16QAM formats, the different RVs may correspond not only to different puncturing schemes, but also to different constellation versions or rearrangements.

Inter-TTI interval

The HSDPA transmission time interval (TTI) is always 2 ms, so it is equivalent to 1 subframe. The inter-TTI interval refers to the number of TTIs (or subframes) between transmissions to the same UE, as shown in Figure 16.

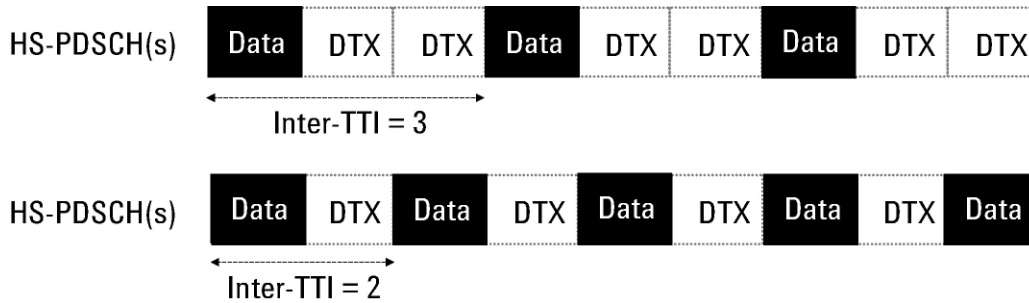

Figure 16. Inter-TTI interval is the number of subframes between transmissions to a UE

The minimum inter-TTI interval that a UE must support is either 1, 2, or 3. This value depends on the HS-DSCH category (defined next). UE with a minimum inter-TTI interval of 1 should be capable of receiving data every sub-frame, a value of 2, every other sub-frame; and a value of 3, every third sub-frame. Therefore, the most capable UEs have a minimum inter-TTI interval of 1.

HARQ processes

The HSDPA system does not re-transmit a data block until it receives an ACK or NACK for that data. It takes the length of time of about five subframes for the BTS to get the associated ACK/NACK response indicating whether the UE correctly received the BTS transmission. Therefore, the inter-TTI interval for a single HARQ process is at least six.

To avoid wasting the time between transmission of the data block and reception of the ACK/NACK response (that is, during the latency period), which would impede throughput, multiple independent HARQ processes can be run in parallel. This increases the data rate to a specific UE.

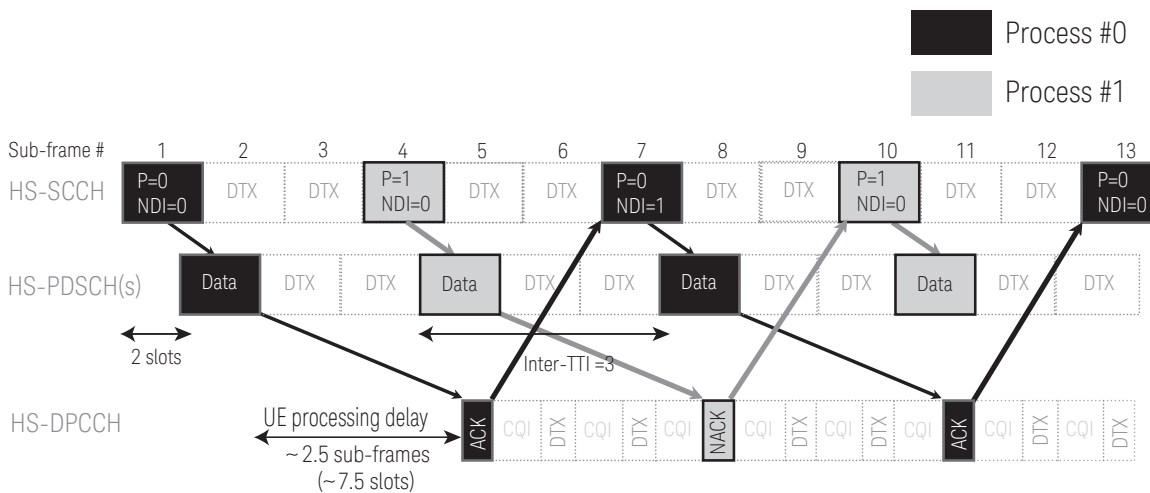

Figure 17. Independent HARQ processes can run in parallel

Figure 17 shows two HARQ processes and an inter-TTI of three. Each HARQ process is assigned an identifier (P = 0 or 1 in the figure), which is used to couple the processes in the transmitter and the receiver. The new data indicator (NDI) is used to distinguish between data blocks. The HS-SCCH indicates new data being transmitted by toggling the NDI value between 0 and 1 within the same process. In this example, process one receives a NACK, which results in retransmission of a packet. The NDI value stays 0.

With an inter-TTI interval equal to two, and three HARQ processes (shown in Figure 18), the throughput is 1.5 times the throughput with an inter-TTI interval of three, and two HARQ processes (shown in Figure 17).

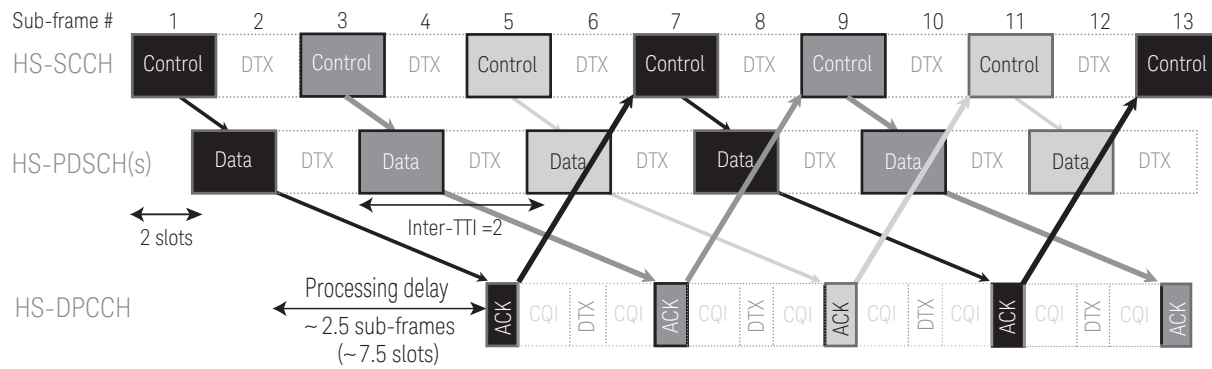

Figure 18. Throughput can be increased by reducing the TTI interval

A UE with a minimum inter-TTI interval of three must be able to support two HARQ processes. A UE with a minimum inter-TTI interval of two must be able to support three HARQ processes. A UE with minimum inter-TTI interval of one must be able to support six HARQ processes, which are the maximum number of processes that can be transmitted in parallel. Soft memory is partitioned across HARQ processes. The BTS chooses any number of processes up to the maximum that the UE class can handle.

Which minimum interval value a UE can support depends on the HS-DSCH category, described in Table 3. Note that UE in Categories 11 and 12 support QPSK only.

Table 3. User equipment categories (Ref: 3GPP TS 25.306 4.5.3 and table 5.1a)

HS-DSCH category (FDD)	Maximum number of HS-DSCH codes received	Minimum inter-TTI interval	Maximum number of bits of an HS-DSCH transport block received within an HS-DSCH TTI	Total number of soft channel bits
Category 1	5	3	7298	19200
Category 2	5	3	7298	28800
Category 3	5	2	7298	28800
Category 4	5	2	7298	38400
Category 5	5	1	7298	57600
Category 6	5	1	7298	67200
Category 7	10	1	14411	115200
Category 8	10	1	14411	134400
Category 9	15	1	20251	172800
Category 10	15	1	27952	172800
Category 11	5	2	3630	14400
Category 12	5	1	3630	28800

UEs of Categories 11 and 12 support QPSK only.

MAC layer packet-scheduling functionality

In addition to the channel coding and physical and transport layer changes, HSDPA implements another change to support fast packet transfer. It relocates the packet scheduling functionality from the network controller to the MAC layer in the Node B (BTS).

The packet scheduling algorithm takes into account the radio channel conditions (based on the CQI from all the UE involved) and the amount of data to be transmitted to the different users. Throughput gains can be maximized by serving the UE that is experiencing the best radio channel conditions, but obviously some degree of fairness in scheduling is required. In addition, there are other factors that the scheduling algorithm could take into account, such as quality of service. The actual throughput will depend heavily on the packet-scheduling algorithm used.

Scheduling, modulation and coding adaptation, and HARQ re-transmissions in HSDPA are fast because they are performed as close to the air interface as possible and because a short frame length is used. Fast scheduling makes it possible to track the fast-channel variations.

HSDPA test models and reference channels

A new test model for BTS transmission testing, Test Model 5, has been added to the conformance specifications. It is used to test the error vector magnitude (EVM) in BTS that support HSDPA with 16QAM modulation, and it includes 8, 4, or 2 HS-PDSCHs depending on the capability of the BTS (Ref: 3GPP TS 25.141 6.1.1.4A).

For testing UE receiver and performance requirements, HSDPA defines five fixed reference channels (FRCs) sets in Release 5 that are similar to the reference measurement channels (RMC) in Release 99 (Ref: 3GPP TS 25.101 9). A sixth FRC set has been in Release 6. Use of the different HSDPA FRCs depends on the UE category:

- FRC H-Set 1 for UE of HS-DSCH categories 1 and 2
- FRC H-Set 2 for UE of HS-DSCH categories 3 and 4
- FRC H-Set 3 for UE of HS-DSCH categories 5 and 6
- FRC H-Set 4 for UE of HS-DSCH category 11
- FRC H-Set 5 for UE of HS-DSCH category 12
- FRC H-Set 6 for UE of HS-DSCH category 7 and 8

A table from the specifications describing FRC H-Set 3 is shown below.

Table 4. FRC H-Set 3 (Ref: 3GPP TS 25 101 A.7.1.3)

Parameter	Unit	Value	
Nominal avg. inf. bit rate	kbps	1601	2332
Inter-TTI distance	TTIs	1	1
Number of HARQ processes	processes	6	6
Information bit payload (NINF)	bits	3202	4664
Number code blocks	blocks	1	1
Binary channel bits per TTI	bits	4800	7680
Total available SMLs in UE	SMLs	57600	57600
Number of SMLs per HARQ processes	SMLs	9600	9600
Coding rate		0.67	0.61
Number of physical channel codes	codes	5	4
Modulation		QPSK	16QAM

Figure 19 shows the corresponding coding.

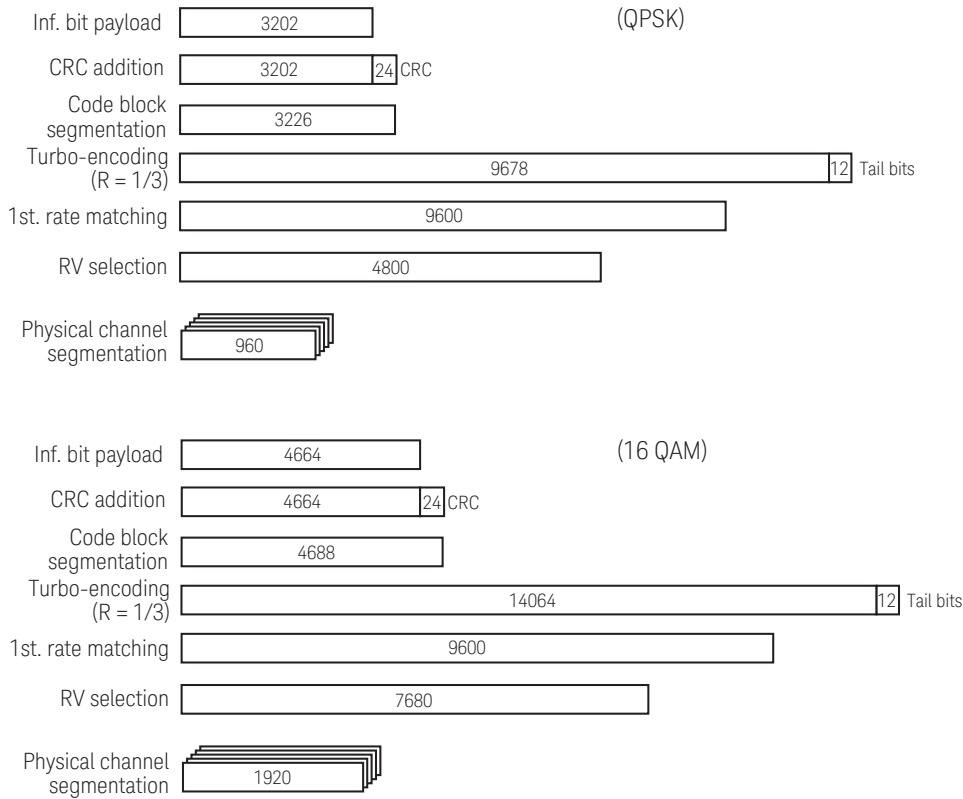

Figure 19. Coding for FRC H-Set 3 (Ref: 3GPP TS 25 101 A.7.1.3)

What comes next?

HSDPA technology is incorporated in W-CDMA Release 5 to increase data throughput and improve the efficiency of the system for downlink data traffic. The main changes introduced by HSDPA are new high speed data channels, the combination of time-division multiplexing with code-division multiplexing, the use of adaptive modulation and coding and hybrid ARQ techniques, and the relocation of MAC layer scheduling to the Node B. With a thorough understanding of these changes, design and test engineers can begin to successfully implement HSDPA into base stations and UE.

Looking forward to Release 6, the content of which is still being finalized, the most significant feature targeted for the radio interface is the enhanced uplink for dedicated channels (EUDCH), more commonly known as high speed uplink packet access (HSUPA). This feature will introduce techniques similar to HSDPA to improve coverage, increase throughput, and reduce delay on the uplink this time. Release 7 will likely include multiple input multiple output (MIMO) antennas, which support higher data rates and are considered an enhancement to HSDPA.

All of these features are documented in the 3GPP Project Plan (www.3gpp.org), which also initiates feasibility studies to improve the radio interface.

Keysight Solutions for HSDPA Design and Testing

Keysight provides technology expertise and comprehensive, flexible, multi-format verification products that can be scaled and upgraded to meet the needs of design and test engineers throughout the R&D lifecycle, from early design to final conformance testing.

Keysight uses common algorithms and user interfaces between simulation software and test hardware to enable real-world verification of designs by relating test data back to theoretical models. This approach helps reduce design costs and cycle times.

HSDPA capabilities are available today on many Keysight design, verification, and testing products, including the Advanced Design System (ADS) communication system designer and W-CDMA library, E4438C vector signal generator, 89600 VSA Series vector signal analyzers, PSA Series spectrum analyzers, and E4406A vector signal analyzer.

These powerful tools give design engineers the ability to design, troubleshoot, and evaluate the performance of HSDPA-capable transmitters and receivers. Keysight also offers seamless analysis between HSDPA and W-CDMA.

Design simulation and verification using dynamically linked solutions

Figure 20 illustrates the Keysight process for simulating and verifying the HSDPA performance of a W-CDMA BTS, UE, or component design.

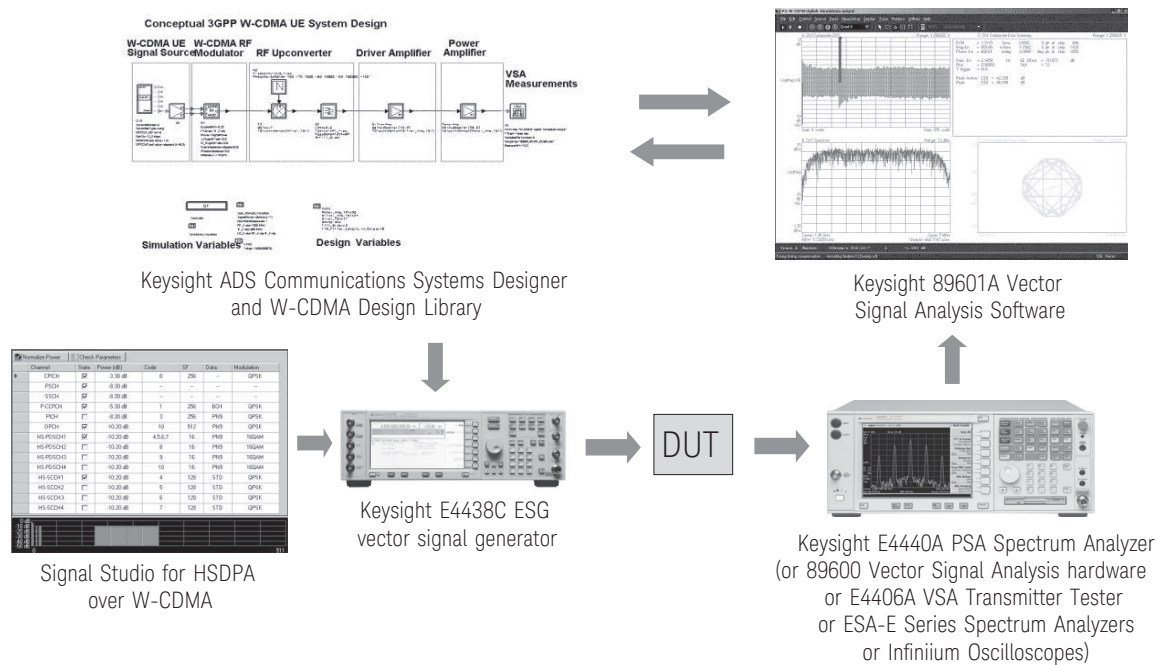

Figure 20. Design simulation and verification process

First, a system design is created and simulated using Keysight's ADS Communication Systems Designer and W-CDMA design library. The simulated signal is analyzed using the 89601A VSA software, which is dynamically linked with the ADS simulation tool on the PC platform, and system design parameters are adjusted accordingly until the design meets specifications.

Once the simulation design phase is complete, different hardware prototype sections can be tested as they return from fabrication. By downloading the simulated signal at various stages of the design to a Keysight E4438C ESG vector signal generator, you can obtain a stimulus signal for the hardware prototype on the bench that has the same characteristics as the signal used in the simulation. Note that Keysight Signal Studio for HSDPA over W-CDMA, software that works with the E4438C, can be used as an alternative to ADS for configuring fully coded downlink and uplink HSDPA channels if intermediate access to signals at various stages of the system design is not required.

The next stage of the process utilizes a Keysight 89600 Series VSA or Keysight E4440 PSA spectrum analyzer. The device under test (DUT) output test signal can be captured with a VSA or PSA and read back into the ADS simulation environment using the 89601A VSA software's simulation signal source capability. This capability enables you to verify the DUT hardware prototype performance at a system level, before all of the hardware sections have been built—which helps minimize design rework later in the development cycle. Once all the hardware prototype sections have been verified using this process, they can be physically integrated and tested together. The whole transmitter system can then be verified on the bench using the Keysight 89600 Series VSAs or E4440A.

The 89601A VSA software will run in the ADS with the same powerful post-processing algorithms used by the VSA/PSA on the bench for measurement-algorithm consistency between simulation and test results. Hardware alternatives include the E4406A VSA (used primarily in manufacturing) and the ESA-E Series spectrum analyzers (used for general-purpose spectrum analysis). These models can be used in place of the 89600 Series VSA or E4440A PSA.

Baseband design simulation and verification

For DUTs with digital inputs and outputs, a similar process applies. In this case, the Baseband Studio digital signal interface module (N5102A) provides fast digital inputs and outputs for the E4438C ESG vector signal generator. The N5102A also connects with a PC platform by using an N5101A Baseband Studio PCI card installed into the PC, allowing an ADS or custom signal to be transferred directly to the DUT. Through the N5110B Baseband Studio for waveform capture and playback software, the N5102A module also provides direct connectivity with the 89601A VSA software.

As an alternative, Keysight 1680, 1690, or 16900 logic analyzers can be used to capture the digital signal and transfer it to ADS or the 89601A VSA software for further analysis. The 16900 pattern generator option provides connectivity to ADS that can be used for digital stimulus of the DUTs digital inputs. See Figure 21.

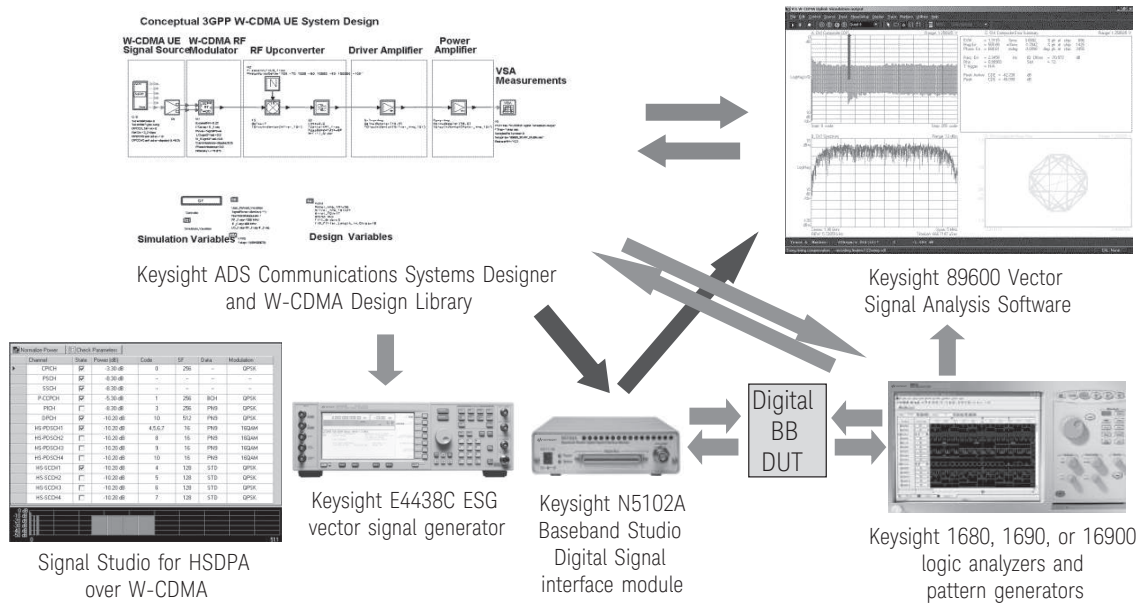

Figure 21. Baseband design simulation and verification process

ADS W-CDMA design library

Keysight’s ADS is a powerful electronic design automation software environment. It offers a complete, front-to-back, high-frequency design, simulation, layout, and verification solution in a single, integrated design flow. The W-CDMA design library for ADS makes it possible to develop and verify 3GPP designs rapidly.

Test Model 5—the channel configuration defined in the specifications that is used to verify the modulation quality performance of an HSDPA BTS transmitter or component—was added to the W-CDMA design library for the ADS 2003C release.

Subsequently, the W-CDMA design library for the ADS 2004A release added both an HSDPA-coded uplink source and an HSDPA-coded uplink receiver. The uplink BTS receiver is particularly useful during the process of simulating and verifying the HSDPA functionality in the UE to ensure that this functionality meets the HSDPA performance requirements given in the conformance test specifications. The receiver can be used to decode the ACK/NACK and CQI responses from the UE, which are necessary to calculate BLER and other performance requirement metrics.

ESG with Signal Studio for HSDPA over W-CDMA

With the E4438C ESG vector signal generator and Signal Studio for HSDPA over W-CDMA software (Option 418), you can perform receiver testing, on HSDPA-capable BTS and UE.

Figure 22 illustrates some of the features of the Signal Studio for HSDPA over W-CDMA software. Most important in testing UEs is the ability to create downlink-transport and physical-layer-coded HSDPA signals, which are needed for BLER analysis. The transport-layer coding can be turned off for troubleshooting applications.

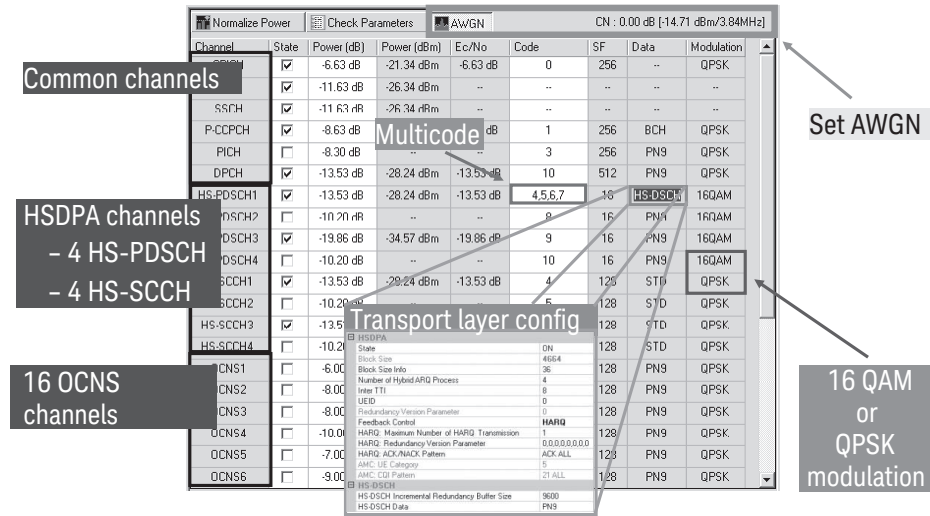

Figure 22. Features of Signal Studio for HSDPA over W-CDMA

The software lets you generate up to 15 multicodes on the downlink transmissions and select either QPSK or 16QAM for the downlink HSDPA transmissions. This capability is useful for testing the demodulation and decoding algorithms present in the baseband section.

Another important feature is the software’s ability to configure the W-CDMA common control channels. Although these channels are not part of the HSDPA architecture, they are needed to establish a radio link between the mobile and the ESG.

The software can generate up to 16 OCNS channels. These are channels that simulate the interference observed by a mobile when the BTS simultaneously transmits to other users in a particular cell. A related feature is the AWGN capability, which simulates the interference caused by other transmitters (TV stations, radio stations, other cellular communications) in the vicinity of the cell area.

The software also can generate up to four downlink HSDPA data channels and corresponding HSDPA control channels. This feature can be used to determine whether the mobile can correctly identify the appropriate HSDPA channel to demodulate and decode.

Signal Studio for HSDPA over W-CDMA enables functional and performance testing of the AMC and HARQ features associated with HSDPA transmissions. Each packet is coded with different parameters, depending on the CQI or ACK/NACK information. Working in an “open loop” mode, Signal Studio simulates the CQI or ACK/NACK information by means of a pattern that you configure. These CQI or ACK/NACK patterns can be as long as 1,280 subframes, which gives you the ability to create sophisticated AMC or HARQ scenarios.

Signal Studio also can generate the basic W-CDMA signal used in establishing a radio link between the ESG and the BTS, and the new HSDPA uplink control channel. Most important for BTS testing is Signal Studio’s ability to create ACK/NACK and CQI patterns that are used to determine how well the BTS ability responds to different scenarios.

Note that Signal Studio is not suitable for testing amplifiers with the HSDPA channels. Instead, the E4438C with the 3GPP W-CDMA FDD personality (Option 400) should be used. Option 400 tests both amplifiers and receivers for the primary W-CDMA FDD communications channels, and it also contains Test Model 5 for testing amplifiers with the HSDPA channels. Option 400 does not, however, test BER/BLER in HSDPA receivers.

HSDPA personality for signal analyzers

The HSDPA measurement personality (Option 210) adds dedicated measurements to the Keysight E4440A PSA spectrum analyzer and the E4406A VSA transmitter tester over W-CDMA measurement personality (Option BAF). These measurement personalities support both BTS (downlink) and UE (uplink) transmitter tests with one license.

The HSDPA personality enables BTS developers to automatically detect HSDPA signals in adaptive modulation and coding (AMC) in signal analysis for modulation quality. For HSDPA downlink development, 16QAM modulated code channels can be correctly detected for the EVM measurement in modulation accuracy and code domain analysis.

Figure 23 shows an example of code domain analysis of HS-PDSCH in 16QAM. Without the HSDPA personality, the HS-PDSCHs with 16QAM modulation would be demodulated assuming a QPSK constellation—resulting in large errors.

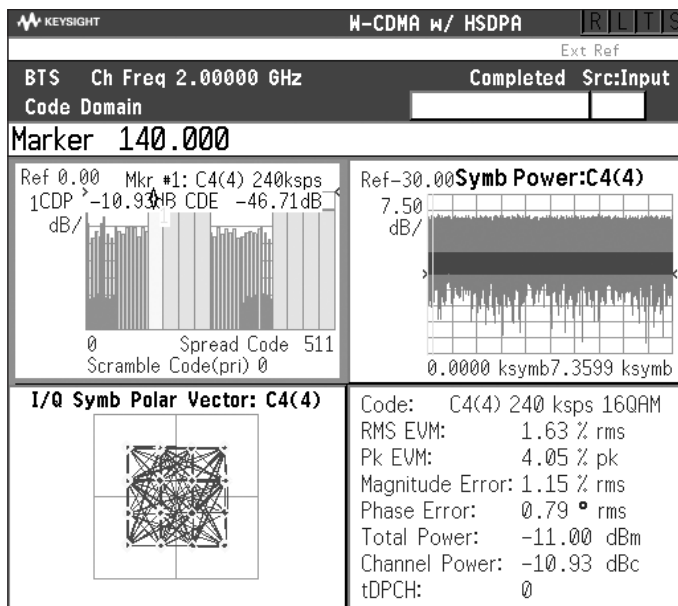

Figure 23. HSDPA personality detects HS-PDSCH as active channel in 16QAM

In addition to symbol EVM and symbol constellations in the code domain, the HSDPA measurement personality can provide other meaningful information for demodulation analysis. For example, IQ error quad view shows magnitude error, phase error, and EVM over the captured interval to make unexpected errors more visible. Demodulated bits (coded bits) stream of the code channel can be represented in both binary and hexadecimal formats.

The HSDPA measurement personality also supports HSDPA uplink signals for modulation quality in composite EVM and code domain analysis.

The Keysight 89601A software with Option B7N, 3G modulation analysis, offers code domain power, code domain error tools, and more to evaluate and troubleshoot W-CDMA/HSDPA signals at the composite level. Alternatively, select any of the automatically-identified active layers and analyze it all the way down to the symbol level. The demodulated bits (coded bits) stream is also provided in both binary and hexadecimal formats.

Power supplies and software for battery drain analysis

Keysight 66319B/D and 66321B/D single- and dual-DC output high performance power supplies provide fast transient output response with an advanced, built-in DSP-based digitizing measurement system. When these power supplies are combined with the 14565A device characterization software, they create a solution for recording, viewing, and analyzing battery drain current over periods from microseconds to weeks in duration.

For testing digital wireless devices, the 66319B/D and 66321B/D power supplies provide the following functions:

- Replace the main battery (single- or dual-output) and power adapter (dual-output)
- Emulate battery characteristics through fast output response and programmable-output resistance
- Minimize transient voltage drop over long wiring resulting from the pulsed current drain
- Provide source/sink capability on the main output for testing and calibrating battery charger circuitry
- Accurately measure battery current drains for all operating modes (off, sleep, standby, and active modes)
- Capture, visualize, and analyze current drain waveforms down to 15.6 μs resolution (with 14565A software)
- Record long-term battery drain up to 1,000 hours; visualize and analyze results by either data log or CCDF display (with 14565A software)

Pre-conformance and conformance RF test solutions

The GS-8800 is an RF design verification system for multiple radio technologies. It supports W-CDMA, HSDPA, GSM, GPRS, EGPRS, cdma2000, 1xEVDO, and AMPS on a single hardware (8960 series) and software platform.

Based on this platform, the GS-8800 plus is a W-CDMA/HSDPA RF conformance system that supports the 3GPP TS 34.121 UE RF conformance test cases in Release 5. The GS-8800 plus enhances the standard system with baseband processors and other instruments used in conformance testing. These are located within the dotted lines in the block diagram shown in Figure 25.

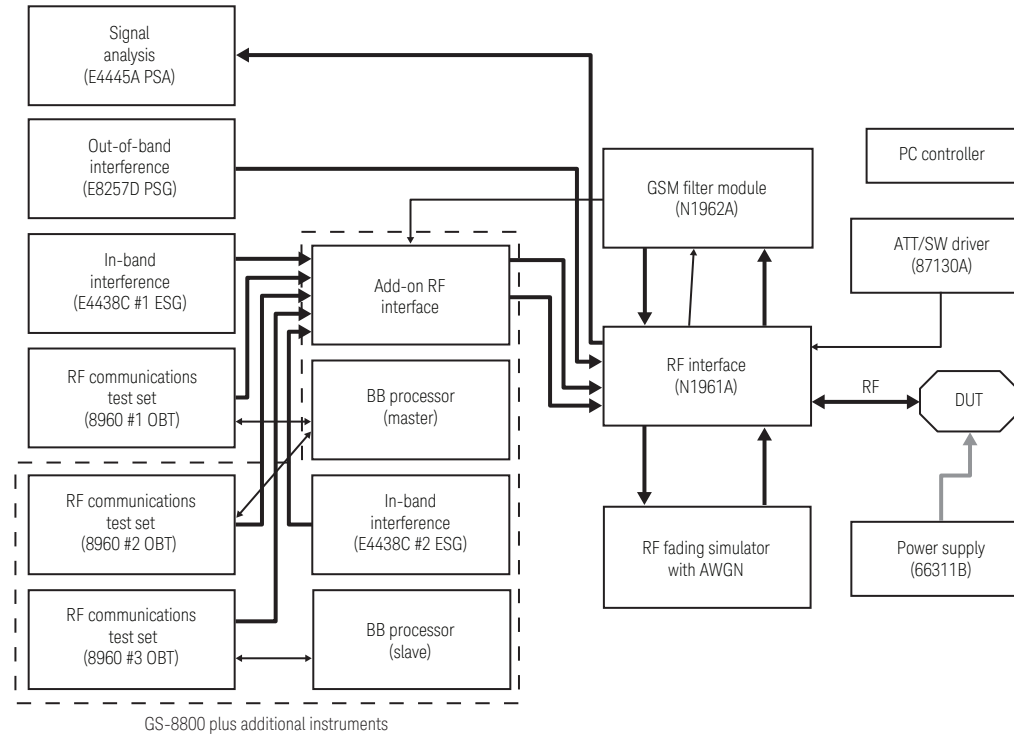

Figure 25. GS-8800 standard and plus systems

Two configurations are available for GS-8800 plus system. The first is the plus1 system for W-CDMA/HSDPA RF pre-conformance testing. The system is called “pre-conformance” because it limits test coverage to those cases that require only one 8960 test set in the system.

A second configuration, the plus2 system, is an RF conformance test system for W-CDMA and HSDPA. The system includes open loop and closed loop diversity test cases. See Figure 26.

GS-8800 TS 34.121 HSDPA tests

Section	Test description	
5.2A	Maximum output power with HS-DPCCH	Standard system
5.9A	Spectrum emission mask with HS-DPCCH	
5.10A	Adjacent channel leakage power ratio (ACLR) with HS-DPCCH	
5.13.1A	Error vector magnitude (EVM) with HS-DPCCH	
6.3A	Maximum input level for HS-PDSCH Reception (16 QAM)	plus1
9.2.1	Demodulation of HS-DSCH - single link performance	
9.2.2	Demodulation of HS-DSCH - open loop diversity performance	
9.2.3	Demodulation of HS-DSCH - closed loop diversity performance	plus2
9.3.1	Reporting of channel quality indicator - AWGN propagation conditions	plus1
9.3.2	Reporting of channel quality indicator - fading propagation conditions	
9.4	HS-SCCH detection performance	plus1

Figure 26. The HSDPA test cases supported by the GS-8800 standard, plus1, and plus2 systems

Development, conformance, and interoperability signaling test solutions

The Anite SAT test system provides functional verification of HSDPA UEs and a complete Release 5 development test system. The Anite SAT system consists of multiple test units (up to 12) with an industry-standard PC controller. The test units are connected to the PC controller by a LAN interface. Each test unit comprises an 8960 test set and an Anite add-on module (the Anite Baseband Processor (ABP)). Multiple test units provide support for simulation of multiple cells and allow testing of handover procedures. The RF paths are combined by means of a power splitter/combiner. Other channel impairments such as co-channel or adjacent channel interferers can be introduced using an external directional coupler or power splitter/combiner.

For HSDPA testing, this solution includes both MAC and RLC functionality in accordance with 3GPP TS 25.321 and TS 25.322, respectively. The following components of the MAC architecture are implemented:

- MAC-hs, which manages flow control, scheduling and priority control, per-user HARQ processes, and transport format/resource combination selection
- MAC-d, which implements transport channel switching, C/T multiplexing, and low control with transport channel routing to MAC-hs

RLC entities can be activated in transparent mode, unacknowledged mode, or full-acknowledged mode and routed to logical channels as needed.

The Anite SAT test system can be controlled in three ways:

- A C/C++ programmable API allows you to write test programs or simulation scenarios in C/C++ using Anite's full Programmer's Toolset (PT) for W-CDMA and HSDPA. In addition to the functions of the test system itself, you have access to the underlying facilities of the host computer such as file and I/O systems. You can, for example, develop programs to control external equipment, to control the UE under test, or to store and retrieve large amounts of test data.
- A test case manager uses Anite's Conformance Toolset (CT) to run conformance test scripts for both W-CDMA and HSDPA.
- For HSDPA, a graphical user interface (GUI) is available to allow control via MAC-hs/RLC or baseband for development testing.

The Anite SAS system is a 2-12 cell signaling test solution for interoperability test (IOT) using 8960 with ABP. It is controlled by a GUI that allows channels to be activated and deactivated. Test configurations can also be stored and reloaded. The system can be used to create complex cell or network simulations to enable thorough interoperability testing.

Summary

HSDPA is a new technology incorporated in W-CDMA Release 5 to increase data throughput and improve the efficiency of 3GPP W-CDMA systems for downlink data traffic.

Some of the major changes introduced in HSDPA are the addition of new channels, the combination of TDM and CDM techniques, the use of adaptive modulation and coding, the use of hybrid ARQ techniques, and the move of the MAC layer scheduling to the BTS.

Keysight supplies the industry with powerful, flexible solutions to help equipment designers and manufacturers keep pace with this evolving technology. Keysight is committed to providing connected solutions that merge simulation and measurement to improve the design process, require fewer design turns, reduce costs, and improve time to market. Current solutions include connected software and hardware solutions for HSDPA component and device modeling and characterization, verification, and testing of BTS and UE. Keysight is committed to expanding its product families with upgrades and new offerings, including solutions for protocol testing and RF conformance testing.

References

The following documents contain the 3GPP Release 5 specifications for HSDPA that were discussed in this application note. They can be found at www.3gpp.org. Also listed are two Keysight application notes that provide background information on W-CDMA, and a third application note that provides information on the HSDPA RF conformance tests for UE.

- [1] 3rd Generation Partnership Project. Technical Specification Group Radio Access Network; UE Radio Transmission and Reception (FDD). Release 6. 3GPP TS 25.101 (V.6.8.0).
- [2] 3rd Generation Partnership Project. Termination Performance Specification; Radio Transmission and Reception (FDD). Release 6. 3GPP TS 34.121 (V.6.1.0).
- [3] 3rd Generation Partnership Project. Technical Specification Group Radio Access Network; BS Radio Transmission and Reception (FDD). Release 6. 3GPP TS 25.141 (V.6.a.0).
- [4] 3rd Generation Partnership Project. Technical Specification Group Radio Access Network; Physical Channels and Mapping of Transport Channels onto Physical Channels (FDD). Release 5. 3GPP TS 25.211 (V.5.7.0).
- [5] 3rd Generation Partnership Project. Technical Specification Group Radio Access Network; Multiplexing and Channel Coding (FDD). Release 5. 3GPP TS 25.212 (V.5.a.0).
- [6] 3rd Generation Partnership Project. Technical Specification Group Radio Access Network; Spreading and Modulation (FDD). Release 5. 3GPP TS 25.213 (V.5.6.0).
- [7] 3rd Generation Partnership Project. Technical Specification Group Radio Access Network; Physical Layer Procedures (FDD). Release 5. 3GPP TS 25.214 (V.5.b.0).
- [8] 3rd Generation Partnership Project. Technical Specification Group Radio Access Network; UE Radio Access Capabilities. Release 5. 3GPP TS 25.306 (V.5.b.0).
- [9] 3rd Generation Partnership Project. Technical Specification Group Radio Access Network; HSDPA Overall Description. Release 5. 3GPP TS 25.308 (V.5.7.0).

- [10] 3rd Generation Partnership Project. Technical Specification Group Radio Access Network; Medium Access Control (MAC) Protocol Specification. Release 5. 3GPP TS 25.321 (V.5.b.0).

- [11] 3rd Generation Partnership Project. Technical Specification Group Radio Access Network; High Speed Downlink Packet Access Physical Layer Aspects. Release 5. 3GPP TR 25.858 (V.5.0.0).

- [12] 3rd Generation Partnership Project. Technical Specification Group Radio Access Network; High Speed Downlink Packet Access: lub/lur Protocol Aspects. Release 5. 3GPP 3GPP TR 25.877 (V.5.1.0).

- [13] 3rd Generation Partnership Project. Technical Specification Group Radio Access Network; UTRA High Speed Downlink Packet Access. Release 4. 3GPP TR 25.950 (V.4.0.0).

- [14] Designing and Testing 3GPP W-CDMA Base Transceiver Stations, Application Note 1355, literature number **5980-1239E**.

- [15] Designing and Testing 3GPP W-CDMA User Equipment, Application Note 1356, literature number **5980-1238E**.

- [16] HSDPA RF Measurements for User Equipment, Application Note, literature number **5989-4099EN**.



myKeysight

www.keysight.com/find/mykeysight

A personalized view into the information most relevant to you.



www.axiestandard.org

AdvancedTCA® Extensions for Instrumentation and Test (AXIe) is an open standard that extends the AdvancedTCA for general purpose and semiconductor test. Keysight is a founding member of the AXIe consortium. ATCA®, AdvancedTCA®, and the ATCA logo are registered US trademarks of the PCI Industrial Computer Manufacturers Group.



www.lxistandard.org

LAN eXtensions for Instruments puts the power of Ethernet and the Web inside your test systems. Keysight is a founding member of the LXI consortium.



www.pxisa.org

PCI eXtensions for Instrumentation (PXI) modular instrumentation delivers a rugged, PC-based high-performance measurement and automation system.



Three-Year Warranty

www.keysight.com/find/ThreeYearWarranty

Keysight's commitment to superior product quality and lower total cost of ownership. The only test and measurement company with three-year warranty standard on all instruments, worldwide.



Keysight Assurance Plans

www.keysight.com/find/AssurancePlans

Up to five years of protection and no budgetary surprises to ensure your instruments are operating to specification so you can rely on accurate measurements.



www.keysight.com/go/quality

Keysight Technologies, Inc.
DEKRA Certified ISO 9001:2008
Quality Management System

Keysight Channel Partners

www.keysight.com/find/channelpartners

Get the best of both worlds: Keysight's measurement expertise and product breadth, combined with channel partner convenience.

For more information on Keysight Technologies' products, applications or services, please contact your local Keysight office. The complete list is available at: www.keysight.com/find/contactus

Americas

Canada	(877) 894 4414
Brazil	55 11 3351 7010
Mexico	001 800 254 2440
United States	(800) 829 4444

Asia Pacific

Australia	1 800 629 485
China	800 810 0189
Hong Kong	800 938 693
India	1 800 112 929
Japan	0120 (421) 345
Korea	080 769 0800
Malaysia	1 800 888 848
Singapore	1 800 375 8100
Taiwan	0800 047 866
Other AP Countries	(65) 6375 8100

Europe & Middle East

Austria	0800 001122
Belgium	0800 58580
Finland	0800 523252
France	0805 980333
Germany	0800 6270999
Ireland	1800 832700
Israel	1 809 343051
Italy	800 599100
Luxembourg	+32 800 58580
Netherlands	0800 0233200
Russia	8800 5009286
Spain	800 000154
Sweden	0200 882255
Switzerland	0800 805353
	Opt. 1 (DE)
	Opt. 2 (FR)
	Opt. 3 (IT)
United Kingdom	0800 0260637

For other unlisted countries:
www.keysight.com/find/contactus
(BP-09-23-14)

