

# Keysight Technologies

## Calibrating Signal Paths in RF/Microwave Test Signals

Increasing Measurement Accuracy  
With Vector and Scalar Technology

Application Note





## Introduction

In any RF test system the ability to achieve instrument-port accuracy at the device under test (DUT) will enhance measurement accuracy and repeatability. Unfortunately, the non-ideal nature of the cables, components and switches in the paths between the instruments and the DUT can degrade measurement accuracy. Vector or scalar calibration is usually required to characterize and correct for this loss of accuracy.

The proper calibration method depends on both the type of measurement and the signal path. For example, measurements of gain and phase require complex-valued vector calibration, which is typically performed with a network analyzer. As another example, measurements of power levels and frequency content may be vector measurements of modulated signals (accurate phase information is essential) or scalar measurements of continuous wave (CW) signals. In these cases, vector measurements are performed with a network analyzer while the scalar measurements are typically performed with a signal generator and a power meter or spectrum analyzer.

This application note provides an overview of three approaches that can be used to calibrate RF signal paths and produce accurate, repeatable measurements. It's important to note that these calibrations are a complement to—and not a substitute for—the calibration of individual instruments within a system.

## Understanding Vector and Scalar Calibration

Within any test system, common elements such as fixturing, switching and cabling will introduce offsets and errors that will affect measurement accuracy. The two types of calibrations used to account for and correct these errors are vector and scalar calibration.

### Vector calibration

This method requires measurements of both the magnitude and phase characteristics of the RF path. This can be done by either performing a network analyzer calibration at the DUT's input and output ports, or by using a calibrated network analyzer to measure the S-parameters of an RF path (see sidebar). The latter method provides a complete, complex-valued characterization of the signal path.

### Scalar calibration

This approach characterizes only the magnitude characteristic of the RF path, which is equivalent to measuring only the magnitude portion of the  $S_{21}$  transmission coefficient in a vector calibration. A common technique involves driving one end of the path with a signal generator and measuring the signal at the other end with a power meter. The magnitude portion of the path response is determined by subtracting the source power level setting (in dBm) from the measured power level (also in dBm). This is repeated at multiple frequencies across the band of interest to determine the overall magnitude characteristic.

Scalar calibrations can achieve very good results as long as high quality components, adapters and cables are used in the system. This helps minimize measurement uncertainty and increase measurement repeatability. However, when compared to a full vector calibration, scalar calibration is less likely to detect any changes in impedance match along a signal path.

## Reviewing S-parameters

“Scattering parameters” or S-parameters are used to describe the way any device, component or path modifies an applied signal. The computed S-parameter coefficients are ratios of measured and applied signals at the ports of the device.

In S-parameter annotation, subscripts are used to indicate the ports of the device: the first number specifies the port that is measured; the second number specifies the port where the signal is applied. For example,  $S_{21}$  indicates a ratio of the signal measured at port 2 versus the signal applied to port 1. In the case of a two-port device (Figure 1) there are four S-parameters, each one describing the reflection or transmission of an applied signal:

- $S_{11}$ , Reflection Coefficient:  
The ratio of the reflected signal measured at port 1 to the signal applied to port 1.
- $S_{21}$ , Transmission Coefficient:  
The ratio of the transmitted signal measured at port 2 to the signal applied to port 1.
- $S_{22}$ , Reverse Reflection Coefficient: The ratio of the reflected signal measured at port 2 to the signal applied to port 2.
- $S_{12}$ , Reverse Transmission Coefficient: The ratio of the transmitted signal measured at port 1 to the signal applied to port 2.

To learn more, please see Application Notes 1287-3, *Applying Error Correction to Network Analyzer Measurements* (pub. no. **5965-7709E**), and 1364-1, *De-embedding and Embedding S-Parameter Networks Using a Vector Network Analyzer* (pub. no. **5980-2784EN**).



Figure 1. Modeling the RF signal path as a two-port device provides the S-parameters needed for calibration and correction

## Comparing the two methods

The best choice of calibration method depends on factors such as the test specification and its measurement and accuracy requirements, the likelihood of inaccuracies internal to the measurement instruments, and the availability of a network analyzer. The advantages and disadvantages of each method are summarized in Table 1.

## Defining our reference point

We will describe the application of vector and scalar calibration to the types of RF signal paths that are present in most systems. The basic system diagram shown in Figure 2 will be our reference point as we explore three different methods that can be used to characterize RF paths:

- Vector calibration of a network-analyzer path
- Vector calibration of a non-network-analyzer path
- Scalar calibration of a non-network-analyzer path

Table 1. Comparing the advantages and disadvantages of vector and scalar calibration.

Calibration type	Advantages	Disadvantages
Vector	<ul style="list-style-type: none"> <li>– Enables complete characterization of the path and, therefore, more accurate measurements</li> <li>– Allows adapter embedding and de-embedding</li> <li>– Provides excellent confidence in path integrity</li> </ul>	<ul style="list-style-type: none"> <li>– Higher cost than scalar because network analyzer is required</li> <li>– Doesn't account for inaccuracies internal to instruments connected to the signal path</li> </ul>
Scalar	<ul style="list-style-type: none"> <li>– Lower cost approach (network analyzer not required)</li> <li>– Can compensate for inaccuracies internal to instruments connected to the path, which may result in better overall accuracy</li> </ul>	<ul style="list-style-type: none"> <li>– Not a complete characterization of the path (magnitude only)</li> <li>– Doesn't support adapter embedding or de-embedding</li> <li>– Provides less confidence in path integrity</li> </ul>

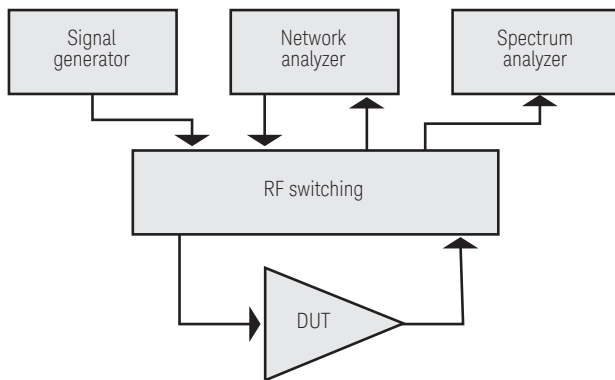

Figure 2. The essential elements of a simplified RF/microwave test system

## Performing Vector Calibration of Network-Analyzer Paths

Network-analyzer paths are those that connect a network analyzer to the DUT. A vector calibration enables the network analyzer to precisely measure the complex-valued S-parameters that fully describe changes in magnitude and phase versus frequency. S-parameter measurements of the DUT are made using a swept continuous wave (CW) signal generated by the network analyzer (Figure 3).

Network analyzers have built-in routines that allow the instrument to compensate for any cabling and RF components that lie between the instrument and the DUT. Mechanical or electronic standards with known characteristics (e.g., shorts, opens, throughs) are used for this purpose. By substituting the standards for the DUT and measuring the response, the network analyzer can generate and store error terms that are recalled as needed to correct measurements of the DUT. In this case, the path data is retained in a set of error terms stored in the analyzer's memory.

When calibrating network-analyzer paths it is important to use the same conditions that will be used to test the DUT: all switch settings, power levels, frequency ranges and so on should be identical. This is especially important if the DUT is an active device that has linear and nonlinear operating modes.

### Removing adapter effects with embedding

The connection of a mechanical standard or electronic calibration module to the DUT cables will often require an adapter on one or both ports of the DUT cables. The addition of these adapters may induce errors such as impedance mismatches, reflections and delays.

You can remove these effects by using a process called “adapter embedding,” which moves the calibration plane towards the network analyzer (Figure 4) and ensures characterization of just the signal paths of interest. In this example, the embedding process moves the calibrated reference plane to the end of the DUT cable from the end of the adapter, where the calibration standards are attached during network analyzer calibration.

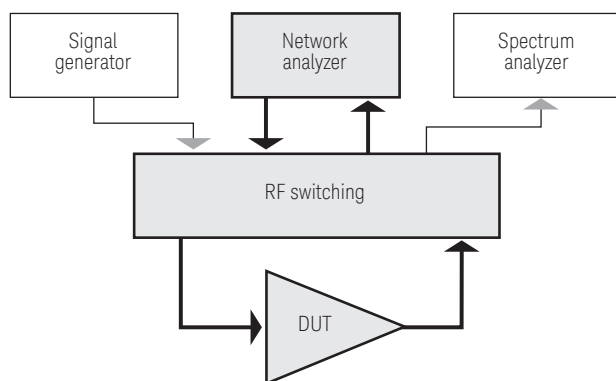

Figure 3. Network-analyzer paths to and from the DUT

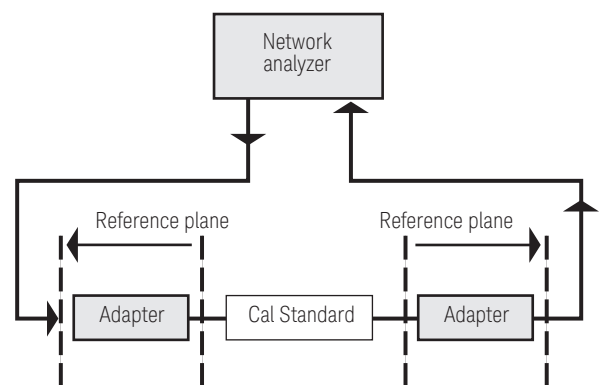

Figure 4. Adapter embedding moves the reference plane closer to the network analyzer, ensuring characterization of just the signal paths of interest

## Performing Vector Calibration of Non-Network-Analyzer Paths

Non-network-analyzer paths connect instruments other than a network analyzer—signal generators, spectrum analyzers, power meters—to the DUT. The measured signals may be either modulated or CW.

Vector calibration of these paths is accomplished by connecting a calibrated network analyzer to the path and measuring its S-parameters. Prior to measuring the RF path, the network analyzer is calibrated in a standalone configuration with special calibration cables. The results of these path-calibration measurements are stored in the system controller for later recall and application.

### Removing adapter effects with de-embedding

Adapters may be required to connect the network analyzer to each system path during the calibration process. The effect of these adapters is usually very small if high quality adapters are used; however, if their effect is significant it can be removed using a process called “adapter de-embedding.” Adapter de-embedding effectively moves the calibration plane away from the network analyzer (Figure 5) to ensure characterization of just the signal path of interest. In this example, the de-embedding process moves the calibrated reference plane from the end of the calibration cable (where the calibration standards are attached during network analyzer calibration) to the end of the adapter where the system path is connected.

### Deriving additional benefits

In addition to high accuracy, two additional benefits come from network-analyzer characterization of the system paths used for modulated DUT measurements. One is greater confidence in path integrity, which comes from the ability to easily measure characteristics such as the return loss of the path ( $S_{11}$  and  $S_{22}$ ). This allows for a more comprehensive self-test of the system and helps minimize the uncertainties caused by input and output mismatches.

The other noteworthy advantage is the ability to modify the path data after a system calibration is completed. This makes it possible to account for separately characterized adapters such as test fixtures or circuit boards that interface to the DUT. Combining these elements with existing path data requires that all S-parameters be known for both the adapter and the path.

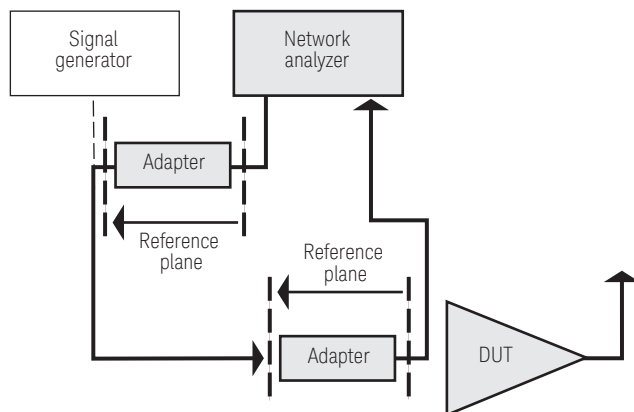

Figure 5. When calibrating paths such as signal-generator-to-DUT-input, adapter de-embedding moves the reference plane away from the network analyzer, ensuring characterization of just the signal path

## Performing Scalar Calibration of Non-Network-Analyzer Paths

While the primary measurement instrument for vector calibration is a network analyzer, the main instrument used for scalar calibration is a power meter, which is the most accurate way to measure absolute power. Scalar calibration also requires a signal generator, which is used to provide signals of known frequency and power. This method typically requires a two-part process that first characterizes the pathway to the DUT input then the signal path from the DUT output.

### Characterizing the path to the DUT input

The first path to measure is the one that connects the signal generator output to the DUT input (Figure 6). You can characterize the loss through this path using a power meter connected to the end of the DUT cable (in place of the DUT input).

The signal generator is configured to provide signals at the range of frequencies and power levels that will be used when testing the DUT. The power meter measures the power output at each frequency and power level, and the offsets (in dB) are calculated and stored in the system controller for later use. The calculated offset accounts for path loss as well as some inaccuracies internal to the signal generator.

This is a scalar measurement because only the magnitude is calculated—there is no phase information. This is usually acceptable because the absolute phase of the signal incident at the DUT input is not important as long as the magnitude response is relatively flat and the phase response is linear over the frequency band of interest.

Assumption: The accuracy of this method depends on minimal mismatch between the input impedance of the DUT and the input impedance of the power meter. It is important to verify these impedances because a large difference will cause significant measurement errors.

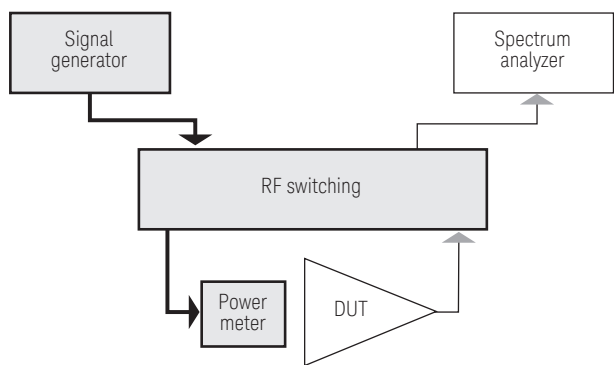

Figure 6. By substituting a power meter at the DUT input, you can measure loss through the input path.

## Characterizing the path from the DUT output

To complete the scalar calibration, we measure the signal path from the DUT output to the spectrum analyzer (Figure 7). The loss through this path can be characterized by applying a known signal source, reading the power level measured by the spectrum analyzer then subtracting the path to the DUT input (described in the previous section).

You can do this by (1) using a feed-through to connect the DUT input cable directly to the DUT output cable, (2) setting up the signal generator to output the required range of frequencies and power levels, and (3) making power measurements with the spectrum analyzer.

The spectrum analyzer should be configured just as it will be for DUT measurements. This is especially true of the input attenuator settings, which often cause wide variations in the spectrum analyzer's input impedance. The resulting calculated offsets will account for path loss as well as some inaccuracies internal to the spectrum analyzer.

Assumption: The accuracy of this calibration depends on the impedance of the DUT output cable being very similar to the input impedance of the power meter. It is important to verify these impedances because a large difference will cause significant measurement errors.

## Measuring adapter effects

Accounting for adapters necessary to perform scalar-path calibrations is usually accomplished by estimating or measuring adapter loss at various frequencies of interest and then accounting for those losses in the offset calculations. However, this is much less accurate than the adapter embedding and de-embedding procedures described in the vector calibration sections.

## Shaping the Future of Test System Development

The use of vector and scalar calibration can increase measurement accuracy by helping you correct for errors in the RF signal paths. The ability to achieve excellent overall accuracy also depends on the instrumentation, I/O connections and software elements you select for your system. Keysight Technologies, Inc. is enhancing your ability to produce accurate, repeatable measurements by offering system-ready instrumentation, PC-standard I/O and open software tools. By creating complementary system elements and supporting continually advancing standards such as LAN, Keysight can help you optimize—and even maximize—system accuracy and performance now and in the future.

To discover more ways to accelerate system development, simplify system integration and apply the advantages of open connectivity, please visit the Keysight Open Web site at [www.keysight.com/find/open](http://www.keysight.com/find/open). Once you're there, you can also sign up for early delivery of future application notes in this series. Just look for the link "Join your peers simplifying test-system integration."

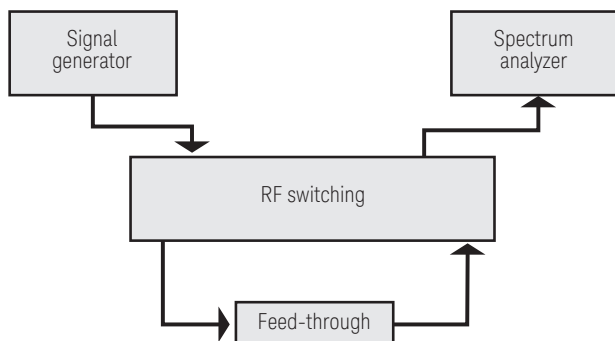

Figure 7. Figure 7: By substituting a feed-through for the DUT, you can measure loss from the DUT output to the spectrum analyzer



## Related Literature

The 1465 series of application notes provides information about the successful use of LAN, WLAN and USB in test systems:

- *Using LAN in Test Systems: The Basics*, AN 1465-9 (pub no. 5989-1412EN)  
<http://literature.cdn.keysight.com/litweb/pdf/5989-1412EN.pdf>
- *Using LAN in Test Systems: Network Configuration*, AN 1465-10 (pub no. 5989-1413EN)  
<http://literature.cdn.keysight.com/litweb/pdf/5989-1413EN.pdf>
- *Using LAN in Test Systems: PC Configuration*, AN 1465-11 (pub no. 5989-1415EN)  
<http://literature.cdn.keysight.com/litweb/pdf/5989-1415EN.pdf>
- *Using USB in the Test and Measurement Environment*, AN 1465-12 (pub no. 5989-1417EN)  
<http://literature.cdn.keysight.com/litweb/pdf/5989-1417EN.pdf>
- *Using SCPI and Direct IO vs. Drivers*, AN 1465-13 (pub no. 5989-1414EN)  
<http://literature.cdn.keysight.com/litweb/pdf/5989-1414EN.pdf>
- *Using LAN in Test Systems: Applications*, AN 1465-14 (pub no. 5989-1416EN)  
<http://literature.cdn.keysight.com/litweb/pdf/5989-1416EN.pdf>
- *Using LAN in Test Systems: Setting Up System I/O*, AN 1465-15 (pub no. 5989-2409EN)  
<http://literature.cdn.keysight.com/litweb/pdf/5989-2409EN.pdf>
- *Next-Generation Test Systems: Advancing the Vision with LXI*, AN 1465-16 (pub no. 5989-2802EN)  
<http://literature.cdn.keysight.com/litweb/pdf/5989-2802EN.pdf>
- *Optimizing the Elements of an RF/Microwave Test System*, AN 1465-17 (pub no. 5989-3321EN)  
<http://literature.cdn.keysight.com/litweb/pdf/5989-3321EN.pdf>
- *6 Hints for Enhancing Measurement Integrity in RF/Microwave Test Systems*, AN 1465-18 (pub no. 5989-3322EN)  
<http://literature.cdn.keysight.com/litweb/pdf/5989-3322EN.pdf>

Earlier notes in the 1465 series provide hints that can help you develop effective low-frequency test systems:

- *Introduction to Test System Design*, AN 1465-1 (pub no. 5988-9747EN)  
<http://literature.cdn.keysight.com/litweb/pdf/5988-9747EN.pdf>
- *Computer I/O Considerations*, AN 1465-2 (pub no. 5988-9818EN)  
<http://literature.cdn.keysight.com/litweb/pdf/5988-9818EN.pdf>
- *Understanding Drivers and Direct I/O*, AN 1465-3 (pub no. 5989-0110EN)  
<http://literature.cdn.keysight.com/litweb/pdf/5989-0110EN.pdf>
- *Choosing Your Test-System Software Architecture*, AN 1465-4 (pub no. 5988-9819EN)  
<http://literature.cdn.keysight.com/litweb/pdf/5988-9819EN.pdf>
- *Choosing Your Test-System Hardware Architecture and Instrumentation*, AN 1465-5 (pub no. 5988-9820EN)  
<http://literature.cdn.keysight.com/litweb/pdf/5988-9820EN.pdf>
- *Understanding the Effects of Racking and System Interconnections*, AN 1465-6 (pub no. 5988-9821EN)  
<http://literature.cdn.keysight.com/litweb/pdf/5988-9821EN.pdf>
- *Maximizing System Throughput and Optimizing System Deployment*, AN 1465-7 (pub no. 5988-9822EN)  
<http://literature.cdn.keysight.com/litweb/pdf/5988-9822EN.pdf>
- *Operational Maintenance*, AN 1465-8 (pub no. 5988-9823EN)  
<http://literature.cdn.keysight.com/litweb/pdf/5988-9823EN.pdf>

Two additional application notes will help you understand and apply error correction, de-embedding and embedding:

- *Applying Error Correction to Network Analyzer Measurements*, AN 1287-3 (pub no. 5965-7709EN)  
<http://literature.cdn.keysight.com/litweb/pdf/5965-7709EN.pdf>
- *De-embedding and Embedding S-Parameter Networks Using a Vector Network Analyzer*, AN 1364-1 (pub no. 5980-2784EN)  
<http://literature.cdn.keysight.com/litweb/pdf/5980-2784EN.pdf>

## Appendix: Hints for Enhanced Performance and Calibration

### Use high quality components

The saying “You get what you pay for” is often true of RF system components. The impedance characteristics of a component are heavily dependent on its mechanical dimensions and tolerances. High quality components will be manufactured with tight control of these characteristics and will be designed to ensure their stability over time. Impedance matching is very important because it dominates the uncertainty of measurements.

### Apply software best practices

The application of object-oriented software design practices can compartmentalize functionality, facilitate code reuse and flexibility, and enhance your ability to respond quickly to system design changes. It will also help minimize the time required to design and develop new or follow-on test systems. As an example, the development of standard methods for measuring, storing and retrieving path data will ensure the availability of consistent, proven calibration methods.

### Define and apply a calibration schedule

As a system ages, changes in four key areas will affect the characteristics of RF signal paths:

- Drift of active components
- Wear and degradation of connectors
- Movement of cables
- Aging of materials, especially dielectrics

The known or expected rate of change in these factors will help determine how often the system paths should be calibrated. Once the system is designed, path calibration should be performed regularly and the data from each calibration should be stored in the system controller. Analysis of this data over time will provide insights into calibration repeatability and will help you determine the required calibration schedule.

Tip: Use RF wear-out connectors for ports that will be used heavily. Also, map out a replacement schedule for these connectors—and re-calibrate the system whenever you change an RF component.

### Utilize additional vector capabilities

Keysight offers vector signal generators (VSGs) and vector signal analyzers (VSAs) that include calibration routines capable of measuring and correcting errors in magnitude and phase. For example, the waveform creation software available with many Keysight VSGs provides the ability to predistort an output signal to correct for errors within both the VSG and a connected signal path. The software for the Keysight 89600 VSA includes a capability called “extended cal” that works with a VSG: the VSA creates a known signal in the VSG, measures the output signal, and then applies vector corrections to achieve the desired output. As with the VSG predistortion capability, this method can correct for errors in the VSG and a signal path.

### Leverage Keysight’s expertise in system design

Keysight has designed numerous custom test systems for a variety of RF and microwave applications. Often the calibration strategy defined for these systems is a core benefit of the design. As an example, the Keysight GS-9200 multi-carrier power amplifier (MCPA) test system is capable of highly accurate and repeatable measurements due largely to its well-defined calibration strategy. The system includes standard routines for adapter embedding and de-embedding; it also provides path data storage and retrieval. Thanks to the system’s flexible software architecture, it has required only modest effort to utilize the core functionality of the GS-9200 as the basis for multiple systems used to test a wide array of RF and microwave DUTs.

**myKeysight**

**myKeysight**

[www.keysight.com/find/mykeysight](http://www.keysight.com/find/mykeysight)

A personalized view into the information most relevant to you.



[www.axiestandard.org](http://www.axiestandard.org)

AdvancedTCA® Extensions for Instrumentation and Test (AXIe) is an open standard that extends the AdvancedTCA for general purpose and semiconductor test. Keysight is a founding member of the AXIe consortium. ATCA®, AdvancedTCA®, and the ATCA logo are registered US trademarks of the PCI Industrial Computer Manufacturers Group.



[www.lxistandard.org](http://www.lxistandard.org)

LAN eXtensions for Instruments puts the power of Ethernet and the Web inside your test systems. Keysight is a founding member of the LXI consortium.



[www.pxisa.org](http://www.pxisa.org)

PCI eXtensions for Instrumentation (PXI) modular instrumentation delivers a rugged, PC-based high-performance measurement and automation system.



**Three-Year Warranty**

[www.keysight.com/find/ThreeYearWarranty](http://www.keysight.com/find/ThreeYearWarranty)

Keysight's commitment to superior product quality and lower total cost of ownership. The only test and measurement company with three-year warranty standard on all instruments, worldwide.



**Keysight Assurance Plans**

[www.keysight.com/find/AssurancePlans](http://www.keysight.com/find/AssurancePlans)

Up to five years of protection and no budgetary surprises to ensure your instruments are operating to specification so you can rely on accurate measurements.



[www.keysight.com/go/quality](http://www.keysight.com/go/quality)

Keysight Technologies, Inc.  
DEKRA Certified ISO 9001:2008  
Quality Management System

**Keysight Channel Partners**

[www.keysight.com/find/channelpartners](http://www.keysight.com/find/channelpartners)

Get the best of both worlds: Keysight's measurement expertise and product breadth, combined with channel partner convenience.

This document was formerly known as Application Note 1465-19

For more information on Keysight Technologies' products, applications or services, please contact your local Keysight office. The complete list is available at: [www.keysight.com/find/contactus](http://www.keysight.com/find/contactus)

**Americas**

Canada	(877) 894 4414
Brazil	55 11 3351 7010
Mexico	001 800 254 2440
United States	(800) 829 4444

**Asia Pacific**

Australia	1 800 629 485
China	800 810 0189
Hong Kong	800 938 693
India	1 800 112 929
Japan	0120 (421) 345
Korea	080 769 0800
Malaysia	1 800 888 848
Singapore	1 800 375 8100
Taiwan	0800 047 866
Other AP Countries	(65) 6375 8100

**Europe & Middle East**

Austria	0800 001122
Belgium	0800 58580
Finland	0800 523252
France	0805 980333
Germany	0800 6270999
Ireland	1800 832700
Israel	1 809 343051
Italy	800 599100
Luxembourg	+32 800 58580
Netherlands	0800 0233200
Russia	8800 5009286
Spain	800 000154
Sweden	0200 882255
Switzerland	0800 805353
	Opt. 1 (DE)
	Opt. 2 (FR)
	Opt. 3 (IT)
United Kingdom	0800 0260637

For other unlisted countries:  
[www.keysight.com/find/contactus](http://www.keysight.com/find/contactus)  
(BP-09-23-14)

