

Keysight Technologies

# Transitioning from GPIB to LXI

Examining Similarities, Differences and Best Practices

Application Note





## Introduction

More than 30 years after its creation, GPIB remains popular due to its ease-of-use and robustness. Today, LAN eXtensions for Instrumentation (LXI) offers capabilities that meet or beat GPIB on both counts. From browser-based configuration and troubleshooting to Ethernet's own 30-year history, LXI enables fast, efficient and cost-effective creation and reconfiguration of test systems. By specifying the interaction of proven, widely used standards, LXI helps you conquer the challenges of product testing without overloading your budget or your team.

*Transitioning from GPIB to LXI* is the third in a series of application notes that will help you manage the shift to LXI from GPIB, PXI or VXI. This note compares GPIB and LXI, sketches hybrid system architectures, outlines a step-by-step approach to system set-up, and describes how to easily modify existing system software to work with LXI devices.

## Comparing System Structures

Every test system depends on four basic elements: measurement hardware, system software, PC-to-instrument connectivity, and cabling to the device under test (DUT). As you consider the transition from GPIB to LXI, it's worthwhile to consider the effects on all four aspects as your preferred system structure evolves from pure GPIB to GPIB/LAN hybrids to all LAN/LXI.

### A typical GPIB system

After more than 30 years of wide-spread use, the basic structure of a GPIB-based system is almost second nature to engineers everywhere: it includes a controller (typically a PC) configured with a GPIB card and up to 14 rack-and-stack instruments daisy-chained together with GPIB cables. The controller and instruments are typically located within a few meters of each other due to the length constraints on GPIB communication.<sup>1</sup>

**Advantages:** From a hardware perspective, GPIB instruments are readily available from either your internal equipment pool or Keysight Technologies, Inc. and numerous other vendors. These highly specialized devices tend to be long-lived because they are generally immune to changes in the system controller. They also include proven measurement routines that provide accurate, reliable and repeatable results. What's more, many of the latest instruments offer enhanced flexibility through downloadable personalities, which provide specialized measurements for applications such as wireless communications.

Connectivity is simple and well-understood with GPIB—and a 30-year history stands as testament to its proven dependability. Routine programming is also relatively simple, whether you choose to use Standard Commands for Programmable Instruments (SCPI), Interchangeable Virtual Instruments (IVI) drivers, or some other type of drivers for communication and control.

**Disadvantages:** The biggest disadvantage may be the need to add a GPIB card to the host PC, increasing both the cost and complexity of the system. This can be especially problematic with notebook computers that need an adapter for the PC Card slot or an available I/O port (e.g., a USB-to-GPIB adapter). Troubleshooting the GPIB card and the associated I/O libraries may take a considerable amount of time. Once everything is up and running, communication may be slower than is possible with LAN and other alternatives.

Depending on your test requirements, GPIB instruments may consume a lot of rack space and add redundant or unnecessary capabilities (e.g., multiple display screens). In some cases, 14 instruments may not be enough to fully test your product. With large multi-instrument systems, bulky GPIB cables and their large connectors can be difficult to route and dress within the confines of a system rack.

System programming has its own challenges, starting with the basic task of tracking down useful, reliable drivers for every instrument in the system. GPIB systems generally require additional trigger lines that you must connect between instruments and then activate via software commands. Timing and synchronization within a system can also complicate programming because GPIB doesn't provide a common clock or trigger line.

### Typical LAN-based systems

Making the transition to LXI doesn't require sweeping changes to your system architecture. Instead, a variety of evolutionary system structures are possible when using LAN communication along with LAN-enabled and LXI-compliant instruments.

In all cases, the starting point is a PC with a built-in LAN port: unlike GPIB-based systems, the PC needs no physical modifications. However, the system structure does require the addition of a switch or gateway (external to the PC) to enable communication with multiple instruments.

1. Longer distances are possible with GPIB bus extenders.

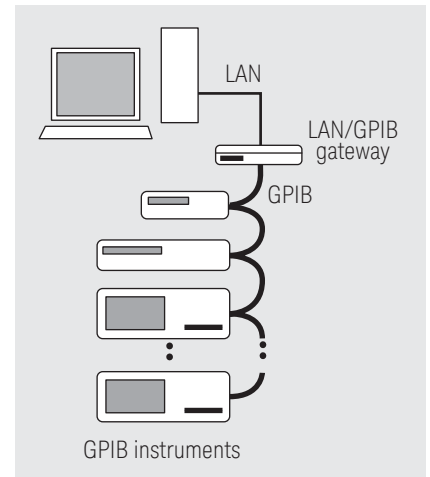

Figure 1. A LAN/GPIB gateway can connect GPIB instruments to a PC's LAN port

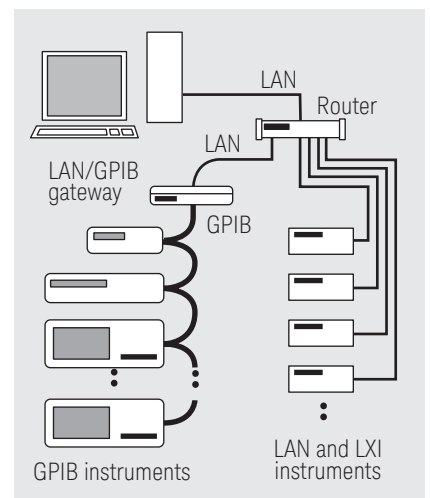

Figure 2. A router plus a LAN/GPIB gateway enables connections of GPIB, LAN and LXI instruments to a PC's LAN port

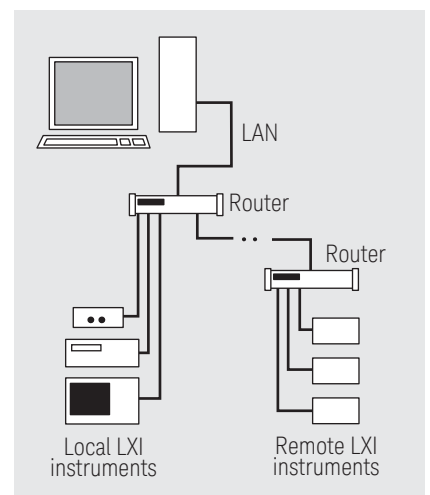

Figure 3. Using multiple routers enables connection of local and remote LXI instruments to a PC's LAN port

**Scenario 1**—GPIB-to-LAN: The easiest initial transition is to use LAN to communicate with an existing GPIB system. A device such as the Keysight E5810A LAN/GPIB gateway enables remote access to GPIB instruments via LAN—and eliminates the need to install a GPIB card in the PC. Addressing remains the same: your system software will see the gateway device as a GPIB interface even though it communicates via LAN. Because your instruments still look like GPIB devices, you can transition your system without changing its software. The E5810A gateway can be mounted in the system rack, which, with a LAN connection, is freed from the distance constraints of GPIB.

**Scenario 2**—GPIB plus LAN: A typical next step in the transition to LXI is the addition of a LAN router between the PC and the LAN/GPIB gateway. This makes it possible to incorporate GPIB, LAN and LXI equipment into a single system by connecting GPIB instruments to a LAN/GPIB gateway and then connecting the gateway and any LAN or LXI instruments to the router.

One important point is worth remembering: although many test instruments are equipped with LAN ports, not all can be controlled via LAN. Some use the LAN port only to communicate with external peripherals—so it's best to check the product manual or built-in help function to verify LAN-specific capabilities. Of course, if an instrument carries the LXI logo, it has passed compliance testing and, at a minimum, can be controlled via LAN, has a browser-accessible Web interface, is provided with an IVI driver, and meets LXI's physical specifications.

**Scenario 3**—All LAN: As more LXI-based products become available, it will be possible to evolve to an all-LAN structure. These systems will include one or more LAN routers as needed to accommodate all of the LXI instruments. Every instrument will be able to take advantage of LAN's speed while utilizing low-cost I/O cabling. The browser-based interface within every LXI instrument will help speed and simplify instrument—or system—configuration and trouble-shooting. The long reach of LAN and the synchronization made possible by the IEEE 1588 precision time protocol (PTP) will enable a variety of new capabilities and applications.

**Advantages of LXI:** In test systems, LXI instruments provide several advantages in hardware, connectivity and programming. From a hardware perspective, there are three key advantages:

- The LXI standard includes classic instruments, modular instruments and building blocks (synthetic instruments or SIs), which means you won't have to sacrifice performance if your system faces size constraints.
- With LXI, the intent is to provide source, measure, power and RF capabilities within one architecture. It has been difficult to provide all of these capabilities in modular architectures such as PXI and VXI.
- The peer-to-peer (instrument-to-instrument) triggering capabilities of Class B and Class A LXI devices allow them to operate and communicate independently, offering the potential to offload many tasks from the system host.

LXI delivers eight important advantages in system connectivity:

- System I/O utilizes the PC-standard LAN port built into most current PCs.
- The number of instruments in a system is limited only by practical considerations such as rack space and the number of available router ports. Every device will have a unique IP address, which can be set manually or automatically.
- It's easy to create a dedicated network for each test system and assign groups of instruments to subnets.
- Instruments can reside near the controller or far away—virtually anywhere on the corporate intranet or the Internet.
- Proven security tools and techniques from the IT world can be used to secure devices and data.

## The recommended configuration

Our suggestion for any LAN-based test system is to create a private, protected network that includes the host PC and the test equipment (each with a private IP address). The simplest approach is built around a LAN router, which provides a buffer between the test system and the corporate intranet. The more advanced approach uses the host PC as the buffer by configuring it with a second network interface card (NIC) and the Internet Connection Sharing (ICS) feature of Microsoft Windows XP.

By adding a second NIC and activating ICS, the host PC serves as the router between the intranet and the local test system. ICS routes traffic from one LAN card to the other and provides network address translation (NAT) capabilities for the private addresses within the system.

As with the router-based approach, this method provides access control, blocks Trojans and worms, and gives the host PC unhindered access to the system network as well as the intranet and Internet. LAN-enabled and LXI instruments can also access the intranet and Internet. However, if the host PC is configured to use DHCP rather than a static IP address then it will have to rely on the corporate intranet being functional and able to provide an IP address.

- The browser-based interface simplifies system configuration and troubleshooting—and many Keysight instruments include interactive set-up, control and monitoring pages.
- The IEEE 1588 PTP enables precise timing and synchronization (Class B and A devices) across local and remote instruments.
- IVI drivers facilitate use of popular test-software development environments.

Finally, Keysight’s approach to LXI provides two advantages in programming:

- The Keysight IO Libraries Suite 14 accelerates the connection and configuration of interfaces and instruments (see “Setting up an LXI system” on pages 4-5).
- Address changes are simple and can be handled in at least three ways: manually, with a declaration of addresses, or through the Keysight IO Libraries.

The cumulative effect of these advantages can help you achieve a faster, smoother transition from GPIB to LAN and LXI.

## Setting Up an LXI System

An actual demonstration is the best way to see how quickly and easily you can configure a LAN-based system. To provide a virtual demo, the following step-by-step procedure outlines the suggested actions and tools that will simplify system configuration during initial setup and future changes.

### Step 1: Connect LAN cables

The first step is to connect all of the instruments to the necessary LAN hardware (router, etc.) using standard LAN cables. The next step is to connect the router to the system’s host PC.

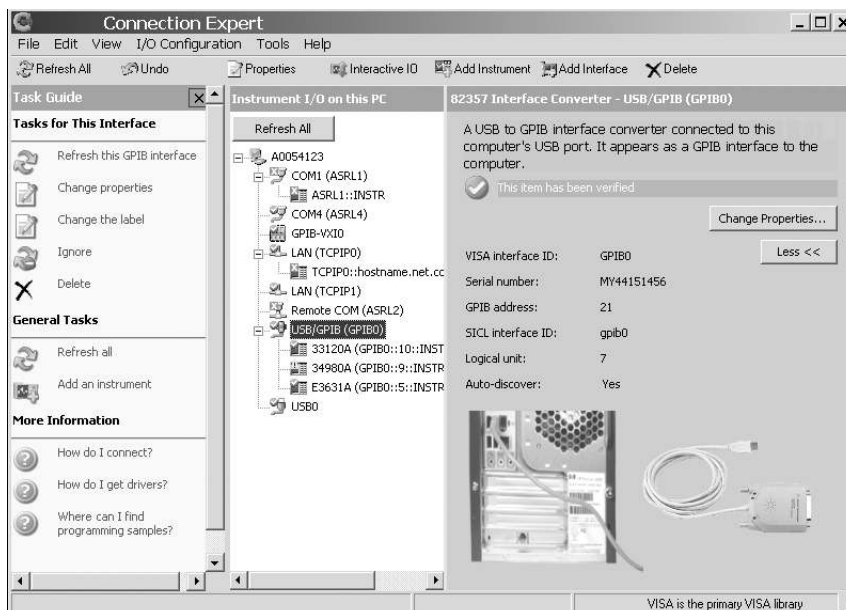

Figure 4. The Keysight Connection Expert simplifies the configuration of PC-to-instrument I/O.

## Step 2: Insert CD into PC

Next, install the Keysight IO Libraries Suite 14 onto the host PC. Provided free with Keysight instruments, Suite 14 works automatically with both Keysight and NI interfaces (fully compatible with NI-488).

It typically takes less than 15 minutes to load the software suite and run the configuration tools. To simplify configuration, Suite 14 recognizes other installed libraries such as NI VISA and configures itself in a compatible manner.

## Step 3: Identify PC interfaces

When you launch Connection Expert, it identifies and configures the various interfaces within the PC—LAN, USB, GPIB and serial (COM). It starts by automatically recognizing the manufacturer, model number and serial number of installed or attached interface cards and converters. Connection Expert completes this step by configuring the appropriate I/O libraries for each interface and converter.

## Step 4: Identify connected instruments

Connection Expert can find and identify instruments from dozens of vendors—not just Keysight—then help you configure them appropriately. One click on any instrument reveals information such as manufacturer, model number, serial number and IP address (or URL). It does this using the “\*IDN?” command.

## Step 5: Test communication links

If you'd like, Connection Expert can automatically test the communication link—LAN, USB or GPIB—with every connected instrument identified in Step 4.

## The LXI Consortium

The LXI Consortium is a not-for-profit corporation initially established by Keysight and VXI Technology, Inc. Its primary purpose is to promote the development and adoption of the LXI standard as an open, accessible standard that identifies specifications and solutions relating to the functional test, measurement and data acquisition industries. The LXI Consortium is open to all test and measurement companies—over 40 are now members—as well as industry professionals, system integrators and government representatives. For more information about The LXI Consortium, please visit [www.lxistandard.org](http://www.lxistandard.org).

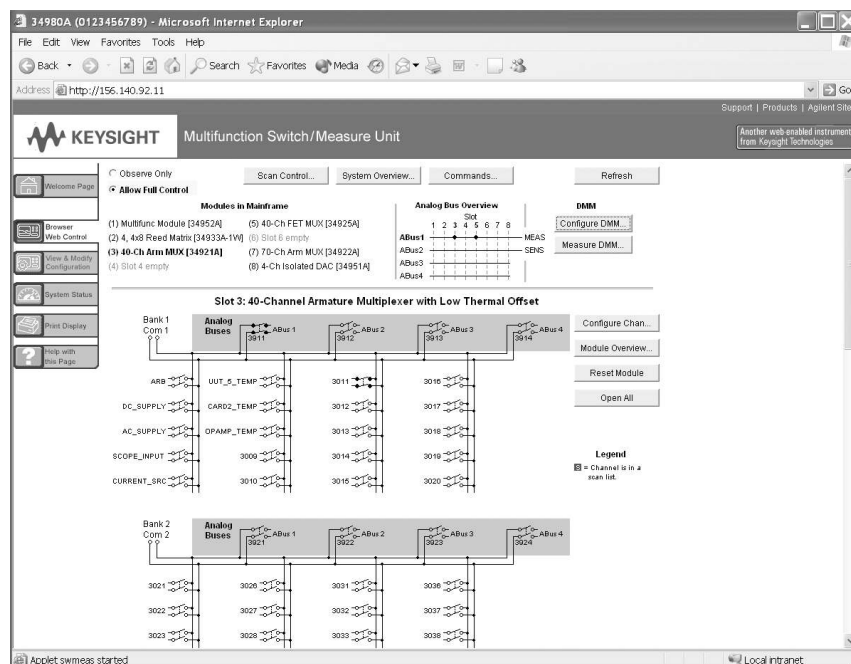

Figure 5. Many of Keysight's LXI instruments include built-in web pages that let you configure the device and make measurements.

## Step 6: Configure LXI instruments

Start any Web browser, type in an LXI instrument's IP address or URL, and view the built-in instrument page. As defined by the LXI Standard, an instrument page includes information such as manufacturer, model number, serial number, firmware revision code and instrument IP address. LXI instruments also provide a configuration page that lets you adjust LAN settings through the Web interface. Keysight instrument pages generally include a product photo and links to additional information. "Intelligent" instruments can also use this page to download firmware revisions or measurement personalities.

Many Keysight instruments provide additional built-in pages that let you interact with the instrument and perform various tasks: make measurements, generate signals, close channels, read values and display results. Some will also let you try program commands or command sequences and verify the instrument's response.

All in all, Keysight IO Libraries Suite 14, Keysight Connection Expert and LXI's browser interface are a powerful combination that can reduce set up time from days to minutes. Best of all, Suite 14 and Connection Expert are designed to work with instruments from virtually every manufacturer. Keysight customers can download Suite 14 at no charge: see [www.keysight.com/find/open](http://www.keysight.com/find/open) for the download link and terms.

## Simplifying Software Changes

Making the transition to LXI doesn't require sweeping changes to your system architecture or your system software. Four important items can simplify the process of modifying your system software to communicate with LXI-compliant devices.

### Dual-interface instruments

Many of Keysight's GPIB instruments that are updated to LXI compliance will have both LAN and GPIB ports. These instruments can be used via the GPIB port without modifying your existing software or through the LAN port with a simple address change in your program. For smaller programs, you can change addresses from GPIB to IP either manually or via search-and-replace. For larger programs or test suites, you can modify the declaration table (aliases) within the program. You can also use Keysight IO Libraries Suite 14, which has its own table of aliases. This approach may cause slightly slower communication but provides a convenient way to get your system up and running.

### VXI-11

From the perspective of a PC application, the VXI-11 communication protocol makes LAN I/O look just like a GPIB connection. In practice, this means applications written for GPIB are likely to work with identical LAN-enabled instruments that implement VXI-11.

### Command-compatible instruments

Instruments that are command-compatible with older instruments can be used with your existing software. As an example, the Keysight 34410A and 34411A digital multimeters have a compatibility mode that mimics the widely used 34401A DMM. The LXI-compliant 34410A and 34411A, equipped with both GPIB and LAN interfaces, can replace a 34401A in a system with either no changes (GPIB) or minor changes (IP addressing for LAN) to the system software.

### Drivers

Many manufacturers are modifying existing instruments to achieve Class C LXI compliance. In most of these cases, the existing driver should work correctly even if you switch to the LXI version of the same model. The IVI drivers required by the LXI standard support another possible solution: "class drivers," which enable instrument substitution.

Instruments within a specific class—such as the DMM class—can be substituted for each other within a test system. The one caveat is the possibility of different results if, for example, you substitute a class-compatible 4½-digit DMM for a 6½-digit model.

## Shifting to the Advantages

With a series of incremental changes to your system architecture and software, you can make the shift to the speed, distance and performance advantages of LAN and LXI. Beyond ease-of-use and robustness that rival GPIB, LXI also includes capabilities such as browser-based configuration and troubleshooting that enable fast, efficient and cost-effective creation and reconfiguration of test systems.

## Transitioning to the Future of Test

LXI solves the key problems faced by system developers: it cuts costs, reduces system size, simplifies integration, accelerates throughput and provides more opportunities for reuse of both hardware and software. These benefits make LXI an architecture for both today and the future.

To help you fully realize those benefits, we've adopted LXI as part of the Keysight Open concept. The strength of Keysight Open is in more than just instruments—it's in the way we help you simplify the entire testing process with PC-standard I/O and open software tools (Figure 6). As technology moves forward, our reliance on widely used standards makes it easy to extend system longevity and incorporate new developments such as LXI.

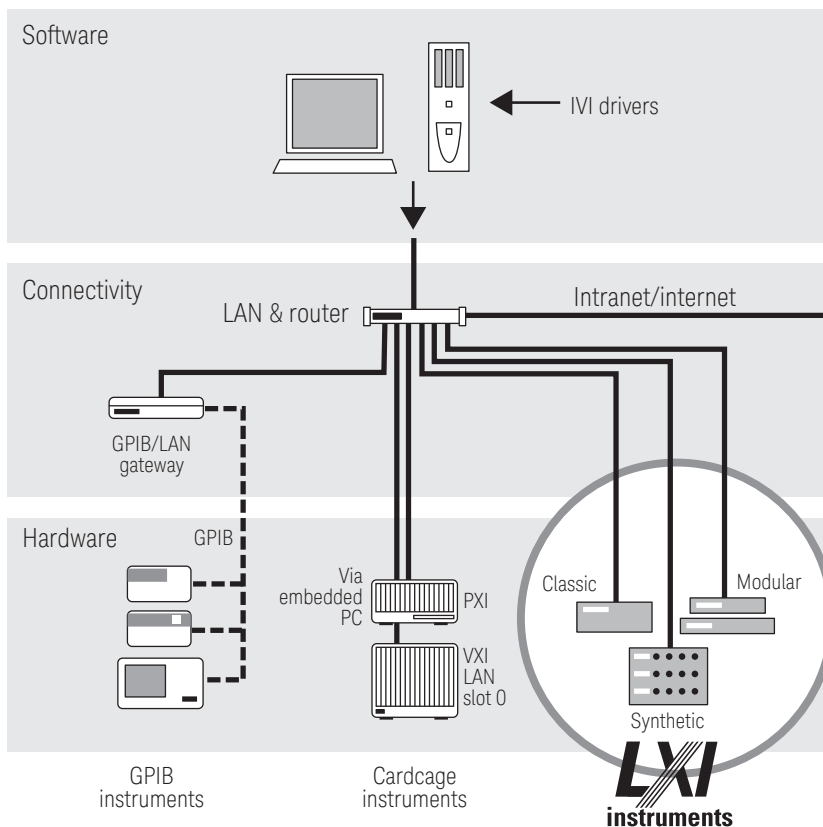

Figure 6. With Keysight Open and LXI, LAN becomes the backbone of test systems that easily incorporate present and future test assets



## Simplify system connectivity

Choose the I/O connection that fits your test requirements: most Keysight Open instruments are available with GPIB, LAN and USB ports. This flexibility lets you select the interface that works best with your system now—and switch to another one in the future. We also make it easy to incorporate GPIB instruments into LAN- and USB-based systems by offering a variety of interface gateways and converters.

## Create versatile measurement solutions

Selecting an Keysight Open instrument for your test system is an easy choice because it's designed for faster throughput as well as easy integration into your test software and your system rack. Whether you choose traditional, modular or building-block instruments, you can connect them quickly and correctly with our IO Libraries Suite. In minutes, its Keysight Connection Expert installs automatically, configures the interfaces, discovers connected instruments from dozens of manufacturers, and verifies communication.

## Achieve efficient development

You shouldn't have to spend time struggling with an unfamiliar programming language just to set up a test. Keysight Open lets you work in the test-software development environment you already know. The key is open software tools such as standard instrument drivers and links to Microsoft Excel or popular programming languages such as Visual Basic, C, Keysight VEE Pro, MATLAB®, LabVIEW, Visual Basic.NET, Visual C++, Visual C# and others. Work where you prefer—and focus on your product, not the code you need to test it.

Through the combined capabilities of Keysight Open and LXI, Keysight can help you and your team open the door to simplified system creation—and new possibilities in testing.

## Related Literature

The 1465 series of application notes provides a wealth of information about the creation of test systems, the successful use of LAN, WLAN and USB in those systems, and the optimization and enhancement of RF/microwave test systems:

- *Introduction to Test System Design*, AN 1465-1 (pub no. 5988-9747EN)  
<http://literature.cdn.keysight.com/litweb/pdf/5988-9747EN.pdf>
- *Computer I/O Considerations*, AN 1465-2 (pub no. 5988-9818EN)  
<http://literature.cdn.keysight.com/litweb/pdf/5988-9818EN.pdf>
- *Understanding Drivers and Direct I/O*, AN 1465-3 (pub no. 5989-0110EN)  
<http://literature.cdn.keysight.com/litweb/pdf/5989-0110EN.pdf>
- *Choosing Your Test-System Software Architecture*, AN 1465-4 (pub no. 5988-9819EN)  
<http://literature.cdn.keysight.com/litweb/pdf/5988-9819EN.pdf>
- *Choosing Your Test-System Hardware Architecture and Instrumentation*, AN 1465-5 (pub no. 5988-9820EN)  
<http://literature.cdn.keysight.com/litweb/pdf/5988-9820EN.pdf>
- *Understanding the Effects of Racking and System Interconnections*, AN 1465-6 (pub no. 5988-9821EN)  
<http://literature.cdn.keysight.com/litweb/pdf/5988-9821EN.pdf>
- *Maximizing System Throughput and Optimizing System Deployment*, AN 1465-7 (pub no. 5988-9822EN)  
<http://literature.cdn.keysight.com/litweb/pdf/5988-9822EN>
- *Operational Maintenance*, AN 1465-8 (pub no. 5988-9823EN)  
<http://literature.cdn.keysight.com/litweb/pdf/5988-9823EN>
- *Using LAN in Test Systems: The Basics*, AN 1465-9 (pub no. 5989-1412EN)  
<http://literature.cdn.keysight.com/litweb/pdf/5989-1412EN.pdf>
- *Using LAN in Test Systems: Network Configuration*, AN 1465-10 (pub no. 5989-1413EN)  
<http://literature.cdn.keysight.com/litweb/pdf/5989-1413EN.pdf>
- *Using LAN in Test Systems: PC Configuration*, AN 1465-11 (pub no. 5989-1415EN)  
<http://literature.cdn.keysight.com/litweb/pdf/5989-1415EN.pdf>
- *Using USB in the Test and Measurement Environment*, AN 1465-12 (pub no. 5989-1417EN)  
<http://literature.cdn.keysight.com/litweb/pdf/5989-1417EN.pdf>
- *Using SCPI and Direct IO vs. Drivers*, AN 1465-13 (pub no. 5989-1414EN)  
<http://literature.cdn.keysight.com/litweb/pdf/5989-1414EN.pdf>
- *Using LAN in Test Systems: Applications*, AN 1465-14 (pub no. 5989-1416EN)  
<http://literature.cdn.keysight.com/litweb/pdf/5989-1416EN.pdf>
- *Using LAN in Test Systems: Setting Up System I/O*, AN 1465-15 (pub no. 5989-2409)  
<http://literature.cdn.keysight.com/litweb/pdf/5989-2409EN.pdf>
- *Next-Generation Test Systems: Advancing the Vision with LXI*, AN 1465-16 (pub no. 5989-2802)  
<http://literature.cdn.keysight.com/litweb/pdf/5989-2802EN.pdf>
- *Optimizing the Elements of an RF/Microwave Test System*, AN 1465-17 (pub no. 5989-3321)  
<http://cp.literature.keysight.com/litweb/pdf/5989-3321EN.pdf>
- *6 Hints for Enhancing Measurement Integrity in RF/Microwave Test Systems*, AN 1465-18 (pub no. 5989-3322)  
<http://literature.cdn.keysight.com/litweb/pdf/5989-3322EN.pdf>
- *Calibrating Signal Paths in RF/Microwave Test Systems*, AN 1465-19 (pub no. 5989-3323)  
<http://literature.cdn.keysight.com/litweb/pdf/5989-3323EN.pdf>
- *LXI: Going Beyond GPIB, PXI and VXI*, AN 1465-20 (pub no. 5989-4371)  
<http://literature.cdn.keysight.com/litweb/pdf/5989-4371EN.pdf>
- *10 Good Reasons to Switch to LXI: Key Advantages that Enable Better Systems*, AN 1465-21 (pub no. 5989-4372)  
<http://literature.cdn.keysight.com/litweb/pdf/5989-4372EN.pdf>

**myKeysight**

**myKeysight**

[www.keysight.com/find/mykeysight](http://www.keysight.com/find/mykeysight)

A personalized view into the information most relevant to you.



[www.axiestandard.org](http://www.axiestandard.org)

AdvancedTCA® Extensions for Instrumentation and Test (AXIe) is an open standard that extends the AdvancedTCA for general purpose and semiconductor test. Keysight is a founding member of the AXIe consortium. ATCA®, AdvancedTCA®, and the ATCA logo are registered US trademarks of the PCI Industrial Computer Manufacturers Group.



[www.lxistandard.org](http://www.lxistandard.org)

LAN eXtensions for Instruments puts the power of Ethernet and the Web inside your test systems. Keysight is a founding member of the LXI consortium.



[www.pxisa.org](http://www.pxisa.org)

PCI eXtensions for Instrumentation (PXI) modular instrumentation delivers a rugged, PC-based high-performance measurement and automation system.



**Three-Year Warranty**

[www.keysight.com/find/ThreeYearWarranty](http://www.keysight.com/find/ThreeYearWarranty)

Keysight's commitment to superior product quality and lower total cost of ownership. The only test and measurement company with three-year warranty standard on all instruments, worldwide.



**Keysight Assurance Plans**

[www.keysight.com/find/AssurancePlans](http://www.keysight.com/find/AssurancePlans)

Up to five years of protection and no budgetary surprises to ensure your instruments are operating to specification so you can rely on accurate measurements.



[www.keysight.com/go/quality](http://www.keysight.com/go/quality)

Keysight Technologies, Inc.  
DEKRA Certified ISO 9001:2008  
Quality Management System

**Keysight Channel Partners**

[www.keysight.com/find/channelpartners](http://www.keysight.com/find/channelpartners)

Get the best of both worlds: Keysight's measurement expertise and product breadth, combined with channel partner convenience.

This document was formerly known as Application Note 1465-22.

For more information on Keysight Technologies' products, applications or services, please contact your local Keysight office. The complete list is available at: [www.keysight.com/find/contactus](http://www.keysight.com/find/contactus)

**Americas**

Canada	(877) 894 4414
Brazil	55 11 3351 7010
Mexico	001 800 254 2440
United States	(800) 829 4444

**Asia Pacific**

Australia	1 800 629 485
China	800 810 0189
Hong Kong	800 938 693
India	1 800 112 929
Japan	0120 (421) 345
Korea	080 769 0800
Malaysia	1 800 888 848
Singapore	1 800 375 8100
Taiwan	0800 047 866
Other AP Countries	(65) 6375 8100

**Europe & Middle East**

Austria	0800 001122
Belgium	0800 58580
Finland	0800 523252
France	0805 980333
Germany	0800 6270999
Ireland	1800 832700
Israel	1 809 343051
Italy	800 599100
Luxembourg	+32 800 58580
Netherlands	0800 0233200
Russia	8800 5009286
Spain	800 000154
Sweden	0200 882255
Switzerland	0800 805353
	Opt. 1 (DE)
	Opt. 2 (FR)
	Opt. 3 (IT)
United Kingdom	0800 0260637

For other unlisted countries:  
[www.keysight.com/find/contactus](http://www.keysight.com/find/contactus)  
(BP-09-23-14)