

Keysight Technologies Medalist i1000D In-Circuit Test System

Data Sheet

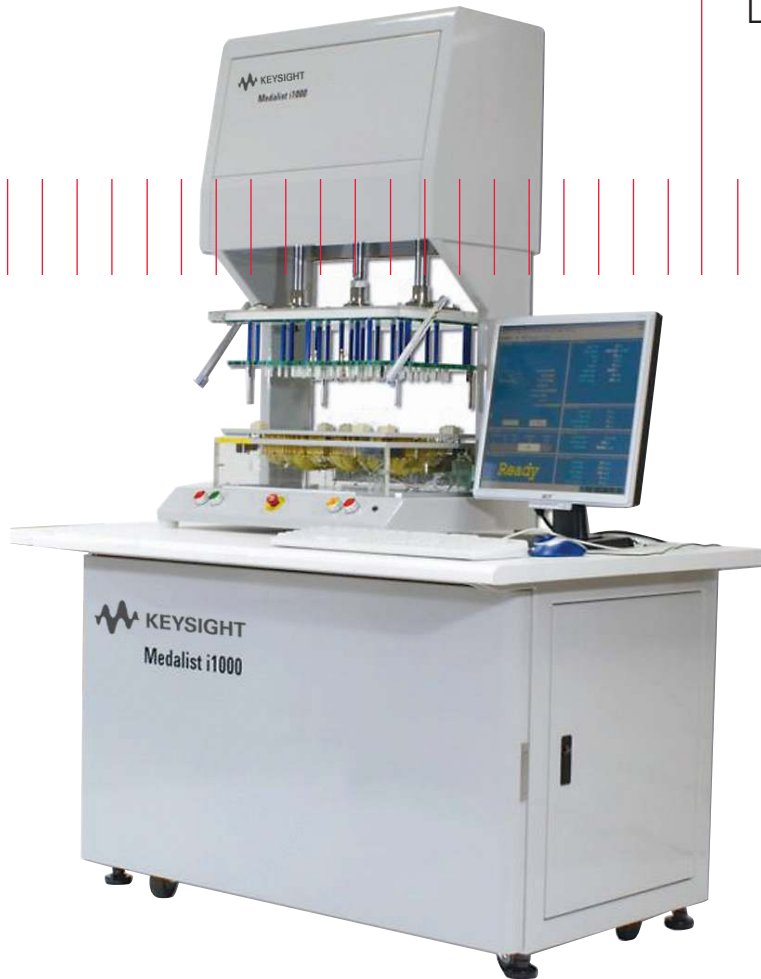

The Keysight Medalist i1000D In-Circuit Tester (ICT) redefines digital testing by bringing electronics manufacturers easy to use and affordable testing for digital devices.

The Keysight Technologies, Inc. Medalist i1000D is now even better. Improving from its previous state of an analog-only ICT, the new digital release of the system now features per pin programmable digital cards and a whole new set of intuitive software graphical user interfaces (GUIs) that makes programming and development effortless.

With its new digital capabilities, the Medalist i1000D now can perform digital PCF/VCL library based testing, Boundary Scan and I²C/SPI serial programming on a simple, low-cost long-wired test fixture. This presents an excellent opportunity for customers who are looking for better test coverage without any increase in cost.

The digital subsystem of the i1000D harnesses the simplicity and power from the industry-leading Medalist i3070 ICT, to bring customers the power to adjust test speeds, drive and receive voltages with just a few clicks of the mouse.

System Highlights

Ease of use

Retaining all the simple yet intuitive features of the earlier U9401/2A model, the new Medalist i1000D software adds on to its arsenal with new features that make development and debugging of digital tests as easy as ABC.

Following the development model of a typical Manufacturing Defects Analyzer, the user can now get a fixture and program up and running in just a few days. When digital test is required, simply assign the test libraries and power supplies using the new Developer GUI and let the i1000D software do the rest.

Simplified GUIs allow the user to quickly make changes to individual tests during debug, with a comprehensive set of menus and buttons, complete with AutoDebug features. This allows inexperienced users to start using the system quickly.

With the Medalist i1000D, unpowered passive analog components can be debugged with the click of a button, so even someone with limited ICT experience can perform a complete analog test debug in a matter of hours.

AutoDebug fine tunes tests so boards pass reliably in production. Statistical measures (CPK) are employed to determine the stability of the test. This automatic feature can reduce the normal debug process which takes days, to just a few hours.

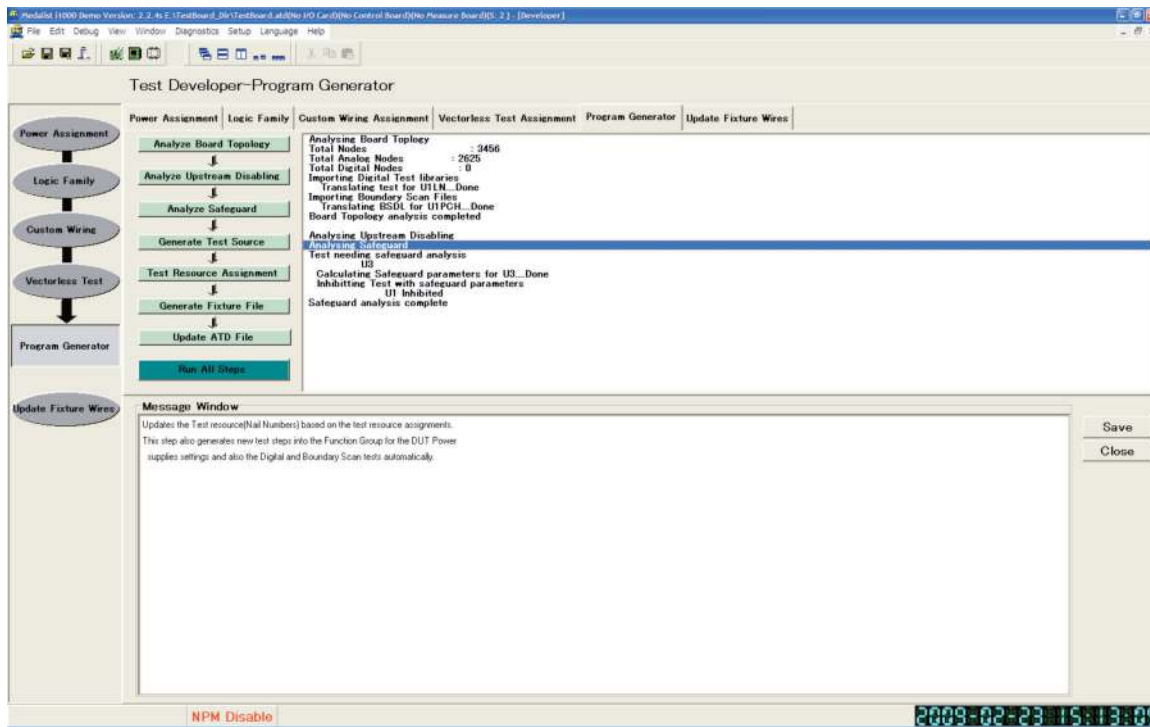

Figure 1. Easy to use Test Developer GUI enables even inexperienced users to deploy a fixture and program in just a few days.

System Highlights

Digital test are usually viewed as complex, difficult to understand and debug by many users. With the i1000D, things are different. The digital debug GUI leverages the control and flexibility of the legendary i3070 PushButton debug GUI, allowing engineers and technicians to have full control of the digital test

parameters and test source codes, yet making it easy to understand. This is achieved by transforming lines of the complicated digital test source codes into simple, easy to understand graphical waveforms. Engineers and technicians performing debug are shielded from the massive lines of codes.

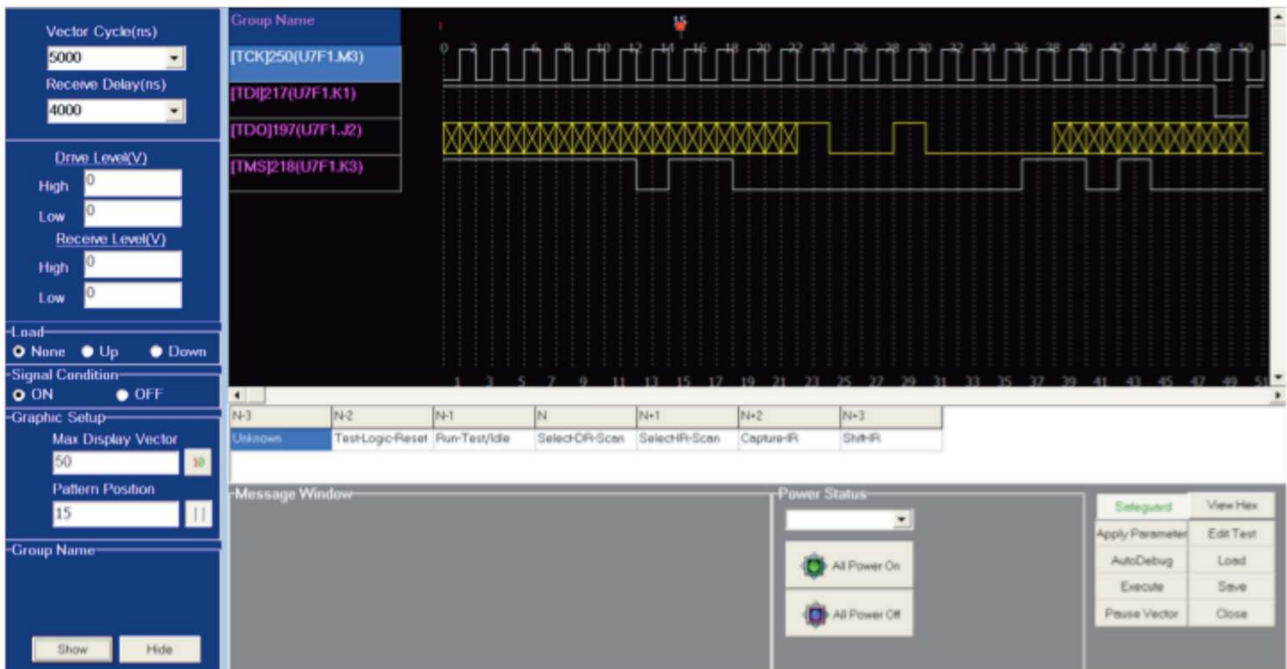

Figure 2. Digital Debugging is made easy on the Medalist i1000D with graphical interface.

VTEP v2.0 Powered Test Suite

Awarded to iVTEP



Manufacturers facing tough time to market pressures can have peace of mind that with the i1000D, they have access to the best vectorless test solutions in the world to help them quickly find defects on digital devices.

The i1000D come with Keysight's award-winning Medalist VTEP v2.0 Powered vectorless test suite. This suite comprises Network Parameter Measurement, iVTEP and the original Medalist VTEP technology. This powerful suite surpasses the traditional Keysight Testjet capabilities and has been proven to provide better test coverage than tradition digital library tests.

And the innovations do not just stop here.

Cover-Extend technology

Awarded to Cover-Extend Technology



The Medalist i1000D is Cover-Extend ready. In Cover-Extend¹ technology, test coverage is no longer limited by test accessibility or library availability. With Cover-Extend, VTEP test can be performed on devices without needing physical test access, thus lowering fixture costs and reducing the number of required test points on the printed circuit board assembly.

Network Parameter Measurement

Awarded to Network Parameter Measurement



Another industry first, Network Parameter Measurement technology detects defects on power and ground pins while iVTEP focuses on ultra low value measurement of signal pins (< 5fF) on Integrated Circuits (ICs). Furthermore, having the original Medalist VTEP as its core means enabling measurements which are 4X more sensitive and 5X better in standard deviation. As technology advances with shrinking packages and faster signaling speeds, VTEP v2.0 is a necessity to meet the challenges of today and beyond.

Automatic guard

The automatic guard feature is a tool for the production test engineer as well as test programmer. It automatically selects different guard points based on board topology for the user during the debug process. This eliminates the need for the user to manually check the schematics for each possible guard point, hence significantly reducing the overall debug time.

Complete Boundary Scan Test Capabilities

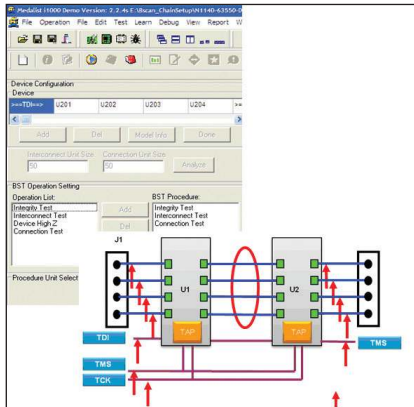

Putting even more ICT power in the hands of its users, Keysight has equipped the i1000D with full boundary scan capabilities, from Standard Boundary Scan and Connect test to Interconnect test. These capabilities help satisfy manufacturers' test needs for Boundary Scan enabled devices, and will ensure manufacturers are geared for the future where there will be increased needs to test Intel®-based peripheral control hubs and processors.

Fixturing

Long-wired MDA Press Down fixtures are not suitable for digital tests. Is this true or false?

While it is commonly perceived to be true, the Medalist i1000D proves this wrong.

The Medalist i1000D runs digital tests using a traditional MDA-style long-wired press down fixture. Boundary Scan tests, Serial Programming, Library-based tests all run without a glitch. Users now have a test solution that is simple and effective, and at the same time keep their operational costs down with the MDA-style fixtures.

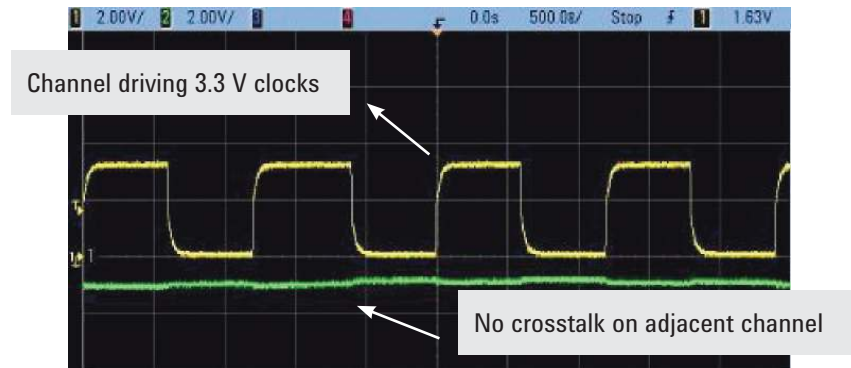

Figure 3. No cross talk on adjacent channels.



Figure 4. Low signal loss.

Fixturing

Standard software and firmware features	
Open/short testing	Shorts pin groups learning
Analog testing	Yes
Vectorless testing	VTEP v2.0
I ² C programming capability	Yes
SPI programming capability	Yes
Boundary scan capability	Yes
Frequency measurement	Yes
AC/DC voltage testing	Yes
Number of analog guarding points	10
First pass yield report	Yes
Quality Test CPK Report	Yes
Component-level coverage report	Yes
Yield enhancement test	Yes
Limited access tools	Keysight Medalist Bead Probe Technology Keysight Cover-Extend
Panel test	Yes
Relay-level diagnostics tool	Built in
SPC quality tool	Yes
Software product	
VTEP v2.0 test suite	Test development software for vectorless test extended performance
Cover-Extend Technology	Extending test coverage to devices without test access using VTEP
Modules and pin cards	
Pin cards	Un-multiplexed analog 128 channel Un-multiplexed hybrid 64 channel
Analog stimulus card	Measurement board
Control card	System control board
Number of modules	Single module design which supports up to a total of 28 pin cards. This supports up to a total of 3456 node count.
64 channel hybrid pin card	
Resource per card	Unmuxed 64 channels per card
Programmable receiver	0 to 4.85 V
Programmable driver	0 to 5 V
Max sink current	Peak 500 mA
Max source current	Peak 500 mA
Pattern rate	Max 2 MPS
Programmable vector cycle	Programmable
Programmable vector cycle resolution	50 ns
Programmable receive delay	Programmable
Programmable receive delay resolution	10 ns

Fixturing

Power supplies		
DUT power supplies	0 V to +20 V 0 V to -14 V	
High voltage DUT power supplies	10 V to +100 V 0 V to -14 V	
Number of supply channel	Normal	High voltage
Programmable 0 to 5 V @ 20 A	Two	One
Programmable 0 to 14 V @ 10 A	None	One
Programmable 0 to 20 V @ 4 A	One	None
Programmable 0 to -14 V @ 5 A	One	One
Programmable 10 to 100 V @ 10 mA	None	One
N6700 DUT Power supply unit	4 x programmable channels 0 to 50 V @ 5 A per channel	
Over-voltage protection	Yes	
Over-current protection	Yes	
System power supplies	AC 200 V – 240 V 10 A	
Software specifications		
Operating system	Windows XP Home Edition	
Support languages	English Simplified Chinese Traditional Chinese (Supports localization)	
Vectorless test technology	VTEP v2.0 Test Suite (Includes VTEP, iVTEP and NPM) Cover-Extend Extest Toggle	
Board/Fixture graphics display	Nails location graphic Pins location graphic Device location graphic	
Probe pin locator	Pin locator with guided probed	
Runtime yield display	Real time FPY (First Pass Yield) display at runtime	
Yield enhancement tool	Auto retest Auto test cycle repeat	
Debug interface	Spreadsheet layout for easy test options selections	
AutoDebug	AutoDebug on analog unpowered test and VTEP v2.0	
Scalability	Single module design of up to 28 slots	
Failure message printer	Uses serial port interface (Printer not included)	
Shipping and installation assistance	Included (Keysight authorized representative)	
Capacitor discharge protection	Yes	
Fixture types supported	Long-wire press-down type	
Hardware specifications		
Maximum nodes	3456	
Pin card	Un-multiplexed analog 128 channels Un-multiplexed hybrid 64 channels	
Printer	Dot-Matrix TM-U220 Series	

myKeysight

myKeysight

www.keysight.com/find/mykeysight

A personalized view into the information most relevant to you.



Three-Year Warranty

www.keysight.com/find/ThreeYearWarranty

Keysight's commitment to superior product quality and lower total cost of ownership. The only test and measurement company with three-year warranty standard on all instruments, worldwide.



Keysight Assurance Plans

www.keysight.com/find/AssurancePlans

Up to five years of protection and no budgetary surprises to ensure your instruments are operating to specification so you can rely on accurate measurements.

Keysight Channel Partners

www.keysight.com/find/channelpartners

Get the best of both worlds: Keysight's measurement expertise and product breadth, combined with channel partner convenience.

www.keysight.com/find/i1000D

For more information on Keysight Technologies' products, applications or services, please contact your local Keysight office. The complete list is available at: www.keysight.com/find/contactus

Americas

Canada	(877) 894 4414
Brazil	55 11 3351 7010
Mexico	001 800 254 2440
United States	(800) 829 4444

Asia Pacific

Australia	1 800 629 485
China	800 810 0189
Hong Kong	800 938 693
India	1 800 112 929
Japan	0120 (421) 345
Korea	080 769 0800
Malaysia	1 800 888 848
Singapore	1 800 375 8100
Taiwan	0800 047 866
Other AP Countries	(65) 6375 8100

Europe & Middle East

Austria	0800 001122
Belgium	0800 58580
Finland	0800 523252
France	0805 980333
Germany	0800 6270999
Ireland	1800 832700
Israel	1 809 343051
Italy	800 599100
Luxembourg	+32 800 58580
Netherlands	0800 0233200
Russia	8800 5009286
Spain	0800 000154
Sweden	0200 882255
Switzerland	0800 805353
	Opt. 1 (DE)
	Opt. 2 (FR)
	Opt. 3 (IT)
United Kingdom	0800 0260637

For other unlisted countries:
www.keysight.com/find/contactus
 (BP-06-09-14)

