

Keysight Technologies

Test Solutions for HDMI

Thorough Characterization

and Validation of HDMI-based Designs

Application Brief



New Challenges

The High-Definition Multimedia Interface (HDMI) is being implemented broadly in devices from high-definition televisions to personal computers to set-top boxes. The overwhelming concern for developers of these products is interoperability. Interoperability starts with the physical layer where the digital content is driven from one device through media such as a cable to a receiving device. Tools to measure the parameters of these devices are required to understand if the device is in compliance, and to how close the device performance is to specification.

When insight is delivered as early as possible in the design cycle, and corrective action is taken on the design, the first condition for success in the market – product quality – is met. Keysight Technologies, Inc. test solutions can provide these insights that help make the right decisions at key moments.

The measurement challenges for HDMI continue to be difficult ones. With the prior release of the HDMI Compliance Test Specification (CTS), data rates were specified to 1.65 Gb/s on each lane, for a composite 5 Gb/s. With CTS 1.3, the highest rate has been increased to 2.25 Gb/s and 3.4 Gb/s, with the possibility of going to 4.5 Gb/s per lane.

It is safe to say that when data rates double the problems you encounter more than double. A simple way to understand this is to consider changing from 1.5 Gb/s to 3.0 Gb/s. The unit interval (UI) changes from 667 ps to 330 ps. If you had 300 ps allowed in your jitter budget for the former device and tried using the same design for the newer requirements, your jitter budget would be gone before you ever got started! The eye would be almost completely closed.

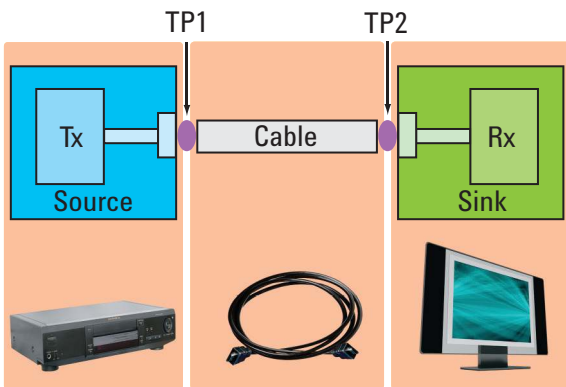

Figure 1. HDMI test points – source, media, and sink

Key tasks

HDMI characterization can be segmented into four areas: source testing, sink testing, media physical layer evaluation, and protocol test. In each of these areas, the HDMI CTS has recommended procedures, methods and equipment to perform these tests. In many cases, there are multiple methods, tools or processes to get the job done. The deciding factors on which method to use may be your comfort level with a particular measurement tool, cost, and/or convenience. Keysight offers solutions in each area to meet your needs from the electrical physical layer to protocol (see Figure 2).

Source test	Media test	Sink test	Protocol test
<p>Source</p> <ul style="list-style-type: none"> ✓ DVD players ✓ Set top boxes ✓ ICs ✓ Cameras 	<p>Cable</p> <ul style="list-style-type: none"> ✓ Cables ✓ PC boards ✓ Connectors 	<p>Sink</p> <ul style="list-style-type: none"> ✓ HDTV monitors ✓ Repeaters ✓ ICs 	<ul style="list-style-type: none"> ✓ Sources ✓ Sinks
<ul style="list-style-type: none"> ■ DSO90000A Infiniium real time oscilloscope ■ N5399A HDMI compliance test software ■ N1080A TPA fixtures 	<ul style="list-style-type: none"> ■ 86100C Infiniium DCA-J/TDR ■ E5071C ENA RF network analyzer 	<ul style="list-style-type: none"> ■ E4887A TMS signal generator ■ N5990A test automation software ■ N1080A TPA fixtures 	<ul style="list-style-type: none"> ■ N5998A HDMI 1.3 protocol analyzer/generator

Figure 2. Keysight HDMI test solutions

Applying expertise

When it comes to quality digital measurements and signal integrity, Keysight has decades of experience in RF, microwave and protocol engineering. We understand the reflections, skin effect, insertion and return loss, impedance profiles as well as jitter budget and tolerance, timing margins, compliance and other issues that digital designers and developers have to face in high data rate standards. As an active member of the HDMI Organization with consistent participation in compliance workshops and specification issues, Keysight has a solid background in the physical, data link, and protocol layers of HDMI.

Thanks to its premier position as a test company, Keysight also has a long history of collaborative innovation with industry leaders. The expertise of Keysight's Application Engineering team reflects these important experiences. But they also put Keysight in a position to develop tools that meet the physical challenges, are customized to the needs of the standard, and are relevant to the way designers and developers need to use them.

Complete, reliable test coverage

But what makes Keysight test solutions so compelling is that they are the best tools, in every category, to meet the challenges presented by HDMI. We developed these tools to match the application's specific needs – real-time and sampling oscilloscopes to verify signal integrity; pattern/protocol generators to create the necessary stimulus signals, BERTs to test jitter tolerance of receivers, time-domain reflectometer (TDR) and a vector network analyzer (VNA) to characterize impedance, and automation software to speed up and simplify the measurement process. That's why most HDMI Authorized Test Centers (ATC) utilize Keysight solutions.

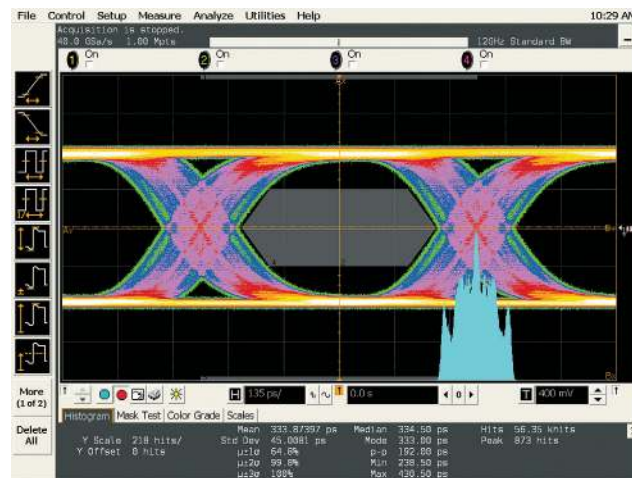

Figure 3. E4887A HDMI TMD5 generator has low intrinsic jitter and controlled jitter injection capability for a quality stimulus signal

Because you can rely on the quality of Keysight equipment, it is the key to easier, faster and more confident testing of your HDMI designs. That takes strain out of engineering and lowers development costs. Accurate results reduce the number of design cycles to help you get to market faster, and they ensure robust products that uphold your hard-won lead in the market.

HDMI Source Test

There are many tests stipulated by the CTS for HDMI Sources (see Table 1). These include measuring standard waveform parameters such as rise and fall times, over and undershoot, but also eye diagrams and jitter analysis where the clock recovery method is stipulated by the HDMI standard. Further, new specified filtering algorithms require equalizing the cable end eye and must be performed to correlate receiver performance.

Table 1. Major HDMI source tests

Test Case	Description
TMDS 7-2	Low Voltage
TMDS 7-4	Transition Time Tests
TMDS 7-6	Inter Pair Skew Test
TMDS 7-7	Intra Pair Skew Test
TMDS 7-8	Clock Duty Cycle Test
TMDS 7-9	Clock Jitter Test
TMDS 7-10	Data Eye Test

Measure with confidence

Whether troubleshooting, capturing contiguous waveforms, ensuring correct operation, or proving compliance, a real-time oscilloscope with active differential probes and test point access fixtures are critical. Noise floor, jitter noise floor, probe accuracy and test fixture quality all affect measurement accuracy. For example, the receiver eye tests examine the minimum level for adequate receiver operation. Poor noise performance in the oscilloscope may deceive you by indicating a lesser level is setup than really is, thereby overestimating receiver performance.

Keysight’s Infiniium 80000B Series Oscilloscopes provide the lowest noise floor, jitter noise floor, and trigger jitter in the industry, enabling more accurate measurements and a better characterization of your device performance. In addition, the InfiniiMax active differential probes provide industry leading noise performance and probe bandwidth and accuracy. Connections to your device are simplified with the N1080A Test Point Access (TPA) plug cable and fixture board, or connect directly to IC pins via the InfiniiMax probes.

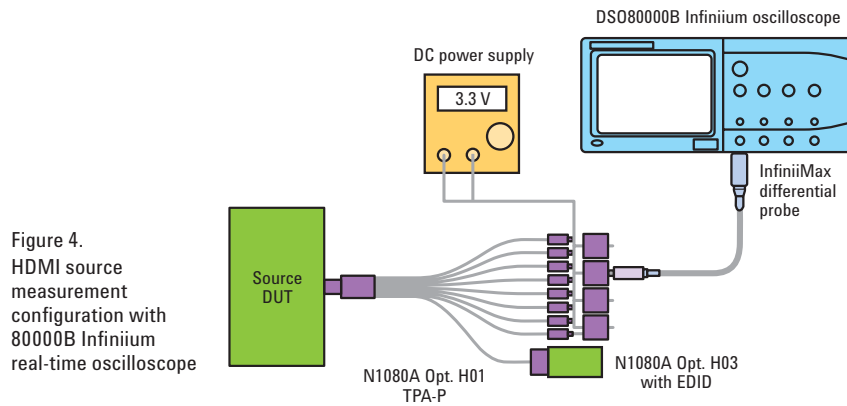

Figure 4. HDMI source measurement configuration with 80000B Infiniium real-time oscilloscope

Automate complex tasks

The N5399A HDMI Electrical Performance Compliance and Validation Software complements the accuracy of the 80000B Series oscilloscopes by simplifying set-up and performing compliance tests (see Figure 5). It runs on the oscilloscope itself, and uses a test framework that has proven value to busy engineers who want quick, accurate answers. This software has the most complete set of HDMI tests, whether you work in an Authorized Test Center or if you are evaluating device performance.

The software brings together Keysight’s intimate knowledge of the oscilloscope and careful interpretation of the specifications to ensure the best results, high repeatability with minimal effort. The software produces an HTML report, complete with screenshots, which makes it easy to share your results, and margin analysis to determine how close you are to the specification (see Figure 6).

If you plan to perform source, sink, and/or media tests, consider using the Keysight N5990A Test Automation Software Platform. It increases the productivity and efficiency of HDMI compliance testing and systematic in-depth characterization. The N5990A provides unprecedented test integration, minimum calibration time and maximum test throughput, as well as ease-of-use for HDMI test.

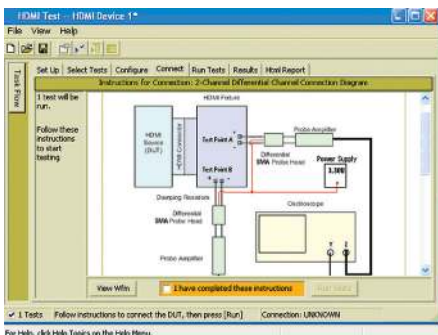

Figure 5. N5399A HDMI electrical test software saves you time by selecting tests, configuring tests, setting up the connection, running the tests, and viewing the results

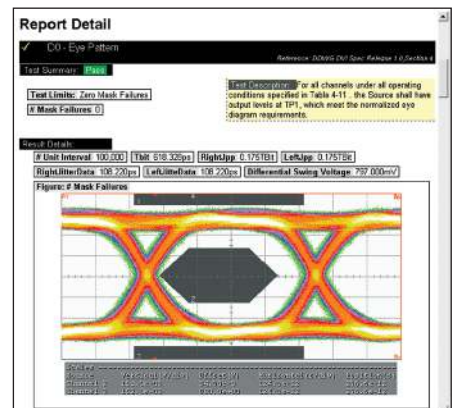

Figure 6. N5399A HDMI electrical test software generates a summary report for your device quickly, including waveforms and the margin of the result to provide further insight

HDMI Sink Test

HDMI sink testing requires a source able to generate a wide range of patterns and the ability to provide a precise jitter signal. The major high-speed tests are sensitivity, skew, jitter tolerance, and timing (see Table 2). Likewise, to maintain compatibility with prior versions of HDMI and the Digital Visual Interface (DVI) standards, interoperability tests are required.

Table 2. Major HDMI sink tests

Test Case	Description
TMDS 8-5	Min/Max Receiver Differential Swing Tolerance
TMDS 8-6	Intra-Pair Skew
TMDS 8-7	Jitter Tolerance
TMDS 8-8	Differential Impedance
TMDS 8-15	Character Synchronization
TMDS 8-19	Pixel Encoding
TMDS 8-20	Video Format Timing
TMDS 8-22	Audio Sample Packet Jitter
TMDS 8-24	Interoperability with DVI
TMDS 8-25	Deep Color

The key to successful sink testing is the ability to inject controlled and calibrated jitter signals to determine jitter tolerance. Since HDMI uses an incoherent design with a TMDS clock rate at 1/10 of the bit rate, this results in different jitter behavior on data and clock. CTS 1.3 recommends using independent clock and data jitter injection to stress sink devices for full characterization. HDMI has other demands on the source, such as video signaling and intra-pair skew which require accurate stimulus signals too.

Measurement accuracy will be determined by the source noise floor (intrinsic jitter), and your ability to control the signal attributes such as injected jitter. The more precise the source, the better the understanding of your receiver designs.

Figure 7. HDMI sink measurement configuration with E4887A HDMI TMDS signal generator

A versatile, precision source

The core of the Keysight HDMI sink test solution is the E4887A HDMI TMDS Signal Generator. It was designed for HDMI CTS 1.3 for testing the jitter tolerance, intra-pair skew and min/max differential swing tolerance of HDMI sink devices as well as conducting cable and video tests. The E4887A provides differential clock and data generation for all TMDS channels. Together with two signal generators, it enables independent clock and data jitter injection for accurate sink characterization. Connections to your device are simplified with the N1080A Test Point Access (TPA) plug adapters.

The E4887A provides clean signals with fast transition times and very low jitter. Many video formats can be generated by the E4887A. Select from more than 50 different IEC/CEA 861 video formats with different color resolutions, or use the frame generator software to control the whole TMDS Signal Generator setup, including jitter injection (see Figure 8). For deep color signal generation, use the E4887A with the Keysight N5990A HDMI 1.3 Protocol/Audio/Video Analyzer and Generator.

An integrated test solution

If you plan to perform source, sink, and/or media tests, consider using the Keysight N5990A Test Automation Software Platform. It increases the productivity and efficiency of HDMI compliance testing and systematic, in-depth characterization. The N5990A provides unprecedented test integration, minimum calibration time and maximum test throughput as well as ease-of-use for HDMI test.

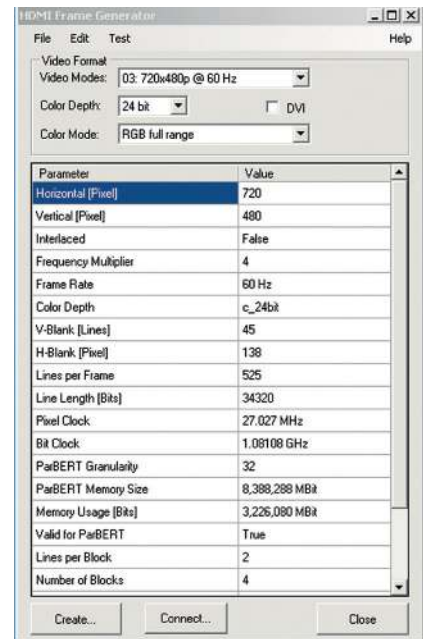
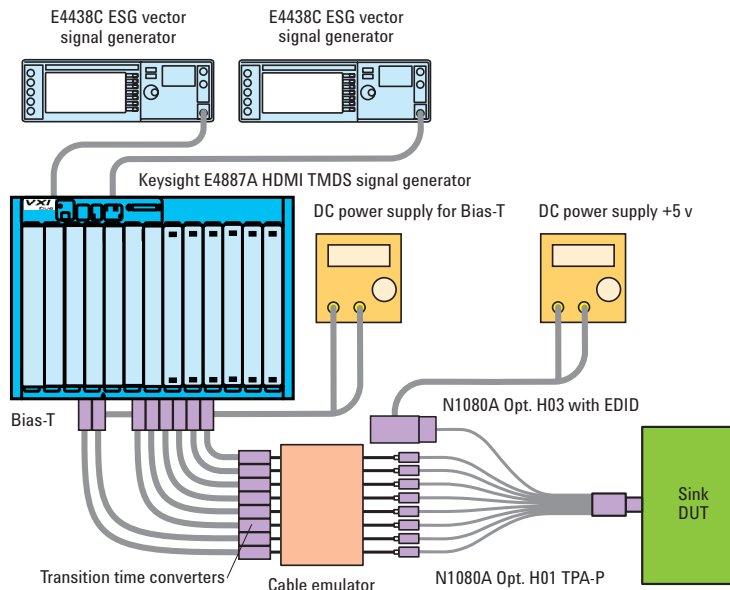

Figure 8. The E4887A frame generator software lets you fully define a test pattern for compliance test or parametric stress test



HDMI Media Test

The integrity of the media that connects an HDMI source and sink truly determines the display quality. So HDMI media tests on cables and printed circuit boards are aimed at preserving video quality through tests like skew, crosstalk, attenuation, and impedance (see Table 3). To assess cable eye diagram measurements or receiver equalization design, a special reference equalization algorithm can be used. Timing tests like skew and eye

diagrams are easily accomplished with a real-time or sampling oscilloscope. But crosstalk, attenuation, and impedance are more commonly measured using either a time-domain reflectometer (TDR) or a vector network analyzer (VNA). For these instruments, accurate measurements occur only after performing a calibration sequence to remove the effects of any cables or fixtures that connect the TDR or VNA to the device under test.

Accurate impedance measurements

Keysight offers two excellent solutions for impedance oriented measurements – the Keysight 86100C Infiniium DCA-J with 54754A Differential TDR/TDT module, or the E5071C ENA RF network analyzer. Connections to the media are made using the N1080A TPA plug and receptacle adapters.

Table 3. Major HDMI cable tests

Test Case	Description
TMDS 5-3	Cable Eye Diagram
TMDS 5-4	Intra-Pair Skew
TMDS 5-5	Inter-Pair Skew
TMDS 5-6	Far End Crosstalk Tests
TMDS 5-7	Attenuation
TMDS 5-8	Differential Impedance Test

The 86100C/54754A TDR utilizes a unique calibration process that can de-embed the effects of cabling, allowing you to see your device and not the test system (see Figure 10). By switching to frequency mode, you can also examine the S-parameters for transmission and impedance/reflection performance of channels, cables, connectors, and transceivers. Digital engineers, already familiar with oscilloscopes, can quickly see the relationships between frequency and time effects without having to purchase and learn new pieces of test equipment.

The Keysight E5071C ENA RF network analyzer is based on frequency domain analysis and includes a built-in swept source and a four-port test set for differential measurements from 9 kHz to 8.5 GHz. A VNA offers higher accuracy than a TDR due to its higher dynamic range and more complete calibration approach, which is important when measuring low insertion loss or low reflection devices. Calibration is accomplished quickly using an Keysight N4431B ECal module that eliminates the need to manually connect the multiple calibration standards.

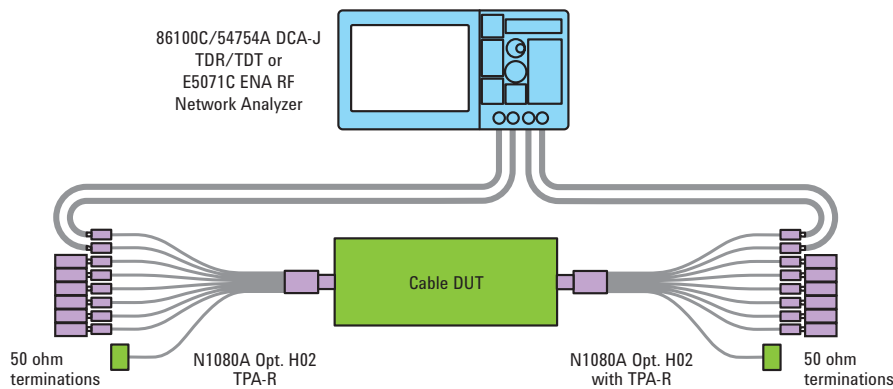

Figure 9. HDMI media measurement configuration using either the 86100C Infiniium DCA-J TDR/TDT or E5071C ENA RF network analyzer

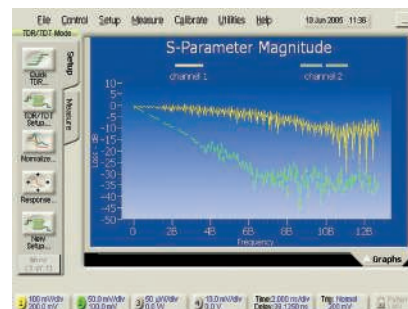

Figure 10. S-parameters can be automatically generated from the 86100C Infiniium DCA-J TDR measurement

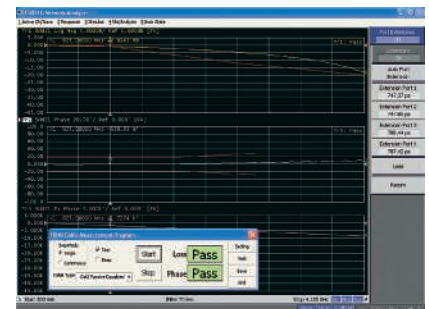

Figure 11. Guided HDMI cable testing using the E5071C ENA RF network analyzer

HDMI Protocol Test

The protocol test for HDMI sources requires the ability to properly analyze the output patterns, while for HDMI sinks the requirement is to generate pre-defined patterns (see Tables 4 and 5). Analysis functions include protocol, audio timing and video timing. Pattern generation includes audio, video and protocol, including deep color patterns.

A protocol analyzer needs to have a deep memory buffer to acquire complex patterns, then process and display the acquisition so that the viewer can identify aspects of each packet. Automatic identification of errors, and where they are located, are the key to troubleshooting the source.

A protocol generator typically works in tandem with a pattern generator to create the necessary HDMI sink waveforms, both audio and video.

Table 4. Major HDMI source protocol tests

Test Case	Description
TMDS 7-16	Legal Codes
TMDS 7-17	Basic Protocol
TMDS 7-18	Extended Control Period
TMDS 7-19	Packet Types
TMDS 7-23	Pixel Encoding – RGB to RGB-only Sink
TMDS 7-24	Pixel Encoding – YCBCR to YCBCR Sink
TMDS 7-25	Video Format Timing
TMDS 7-26	Pixel Repetition
TMDS 7-27	AVI InfoFrame
TMDS 7-28	IEC 60958/IEC 61937
TMDS 7-29	ACR
TMDS 7-30	Audio Sample Packet Jitter
TMDS 7-31	Audio InfoFrame
TMDS 7-32	Audio Sample Packet Layout
TMDS 7-33	Interoperability with DVI
TMDS 7-34	Deep Color
TMDS 7-35	Gamut Metadata Transmission
TMDS 7-36	High Bitrate Audio
TMDS 7-37	One Bit Audio

Table 5. Major HDMI sink protocol tests

Test Case	Description
TMDS 8-16	Acceptance of All Valid Packet Types
TMDS 8-21	Audio Clock Regeneration
TMDS 8-23	Audio Formats

Powerful protocol analysis/generation

The Keysight N5998A HDMI 1.3 Protocol/Audio/Video Analyzer and Generator is the ideal solution for protocol analysis and generation. For protocol analysis, it can capture up to 4 GB of data, post process the results, and help you identify the errors. As a protocol generator, it can provide many patterns directly (see Figure 13), or when used in conjunction with the E4887A TMDS Signal Generator, provide a complete solution. In addition, it provides an EDID writer capability to help identify the HDMI source.

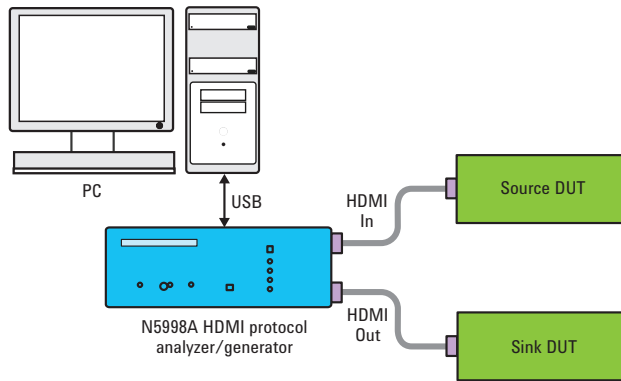

Figure 12. HDMI protocol measurement configuration using the N5998A HDMI 1.3 Protocol/Audio/Video analyzer and generator

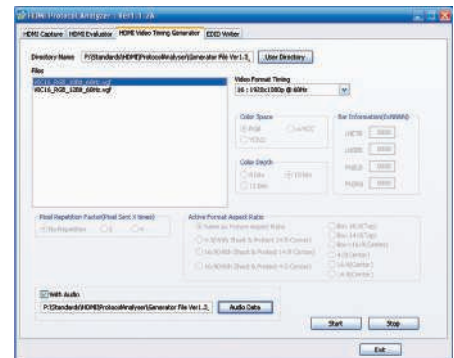

Figure 13. The N5998A HDMI video timing generator lets you configure common test patterns for compliance or stress test

Keysight HDMI Offerings



80000B Series Infiniium 13 GHz Bandwidth Oscilloscope

The Keysight 80000B Series Infiniium oscilloscopes and InfiniiMax probing system deliver the highest performance real-time measurement system available. The Infiniium 80000B Series offers the industries lowest noise floor, jitter noise floor, and trigger jitter, making it the ideal tool for signal integrity and jitter measurements. Models are available from 2 GHz to 13 GHz, and can be upgraded in bandwidth for future needs. InfiniiMax probes are available in differential and single-ended measurements for maximum measurement flexibility.

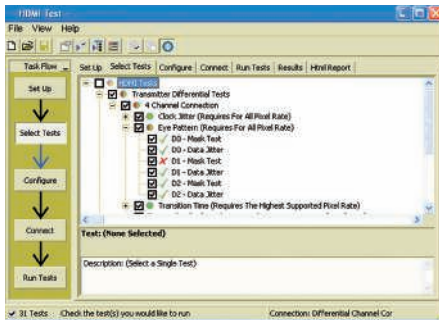

N5399A HDMI Electrical Compliance Test Software

The Keysight N5399A HDMI electrical performance validation and compliance software for Infiniium 80000 Series oscilloscopes provides a fast and easy way to verify and debug your HDMI designs. The HDMI electrical test software allows you to automatically execute HDMI electrical checklist tests, and displays the results in a flexible report format. In addition to the measurement data, the report provides a margin analysis that shows how closely your device passed or failed each test.



N5998A HDMI 1.3 Protocol/Audio/Video Analyzer and Generator

The Keysight N5998A HDMI 1.3 Protocol/Audio/Video Analyzer and Generator can act as a recommended protocol analyzer, audio timing analyzer and video timing analyzer. It is controlled by HDMI analysis software running on an external PC. The HDMI protocol generator provides patterns required for source tests, and works with the E4887A HDMI Pattern Generator for complete source testing. The protocol analyzer provides numerous analysis tools and is able to capture up to 4 GB of data. The Keysight N5998A also offers deep color support and the ability to write EDIDs.

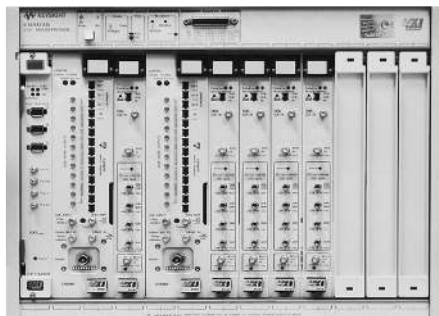

E4887A HDMI TMDS Generator

The Keysight E4887A HDMI TMDS Signal Generator provides parallel signals with low intrinsic jitter and fast edges for data rates up to 3.4 Gb/s or 7 Gb/s with 1 or 2 channel jitter capability. The HDMI frame generator software is ideal for manual testing and debugging. It configures the generator with a wide variety of HDMI video frames. The software controls up to two E4438C vector signal generators as well as the TMDS signal generator for defined jittered signals for jitter tolerance testing. When used with the N5998A HDMI protocol generator, complete HDMI source testing is possible.

Keysight HDMI Offerings



E5071C ENA RF Network Analyzer

The Keysight E5071C ENA RF network analyzer offers the highest RF performance and fastest speed in its class, with a 9 kHz to 8.5 GHz frequency range and versatile functions. Low trace noise and wide dynamic range provide very high accuracy measurements on low level signals. The optional 4-port model or multi-port test set allows differential measurements to be made quickly and easily. When used with the appropriate ECal module, calibration is performed quickly with high accuracy. Automated HDMI cable testing is accomplished with a Visual Basic program.



86100C Infiniium DCA-J Wide-Bandwidth Oscilloscope with TDR

The Keysight 86100C Infiniium DCA-J can view optical and electrical waveforms with bandwidths to 80 GHz electrical and 65 GHz optical. Jitter analysis is simplified via a one-button approach to review the random and deterministic jitter components. With the 54754A Differential TDR/TDT module, you can characterize impedance and crosstalk in channels and view the results in either time-domain or S-parameters.

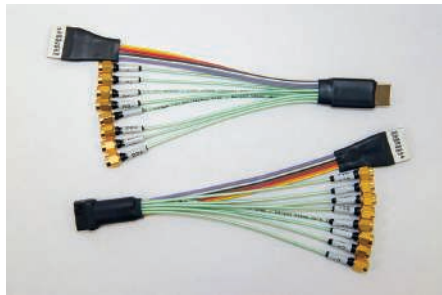

N1080A Test Point Access Adapters

The Keysight N1080A HDMI test point access adapters are well suited for nearly every test, providing the best rise time, excellent skew and the ability to connect into tight spaces. They are offered in three different configurations: Option H01 is a TPA with a plug and is typically used, in conjunction with the low frequency board, for testing sources and sinks. Option H02 is a TPA with a receptacle, typically used in pairs for testing cables, and with the plug allows TDR calibration. Option H03 is the low frequency board used for various tests on both the sink and source modules.

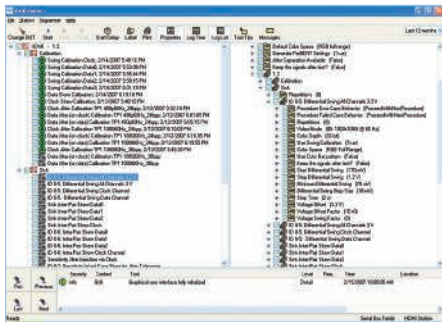

N5990A Test Automation Software Platform

The Keysight N5990A Test Automation Software Platform was designed to automate overall HDMI compliance testing and for systematic, in-depth device characterization. It complements and integrates the N5399A HDMI Electrical Compliance Test Software. It controls the associated Keysight instruments from a PC, providing unprecedented test integration, minimum calibration time and maximum test throughput as well as ease-of-use. One button compliance testing, with results displayed on screen, or exported to Excel or other formats allow further data analysis and collection. The system is expandable and supports other high-speed standards in addition to HDMI.

Keysight HDMI Measurement Solutions

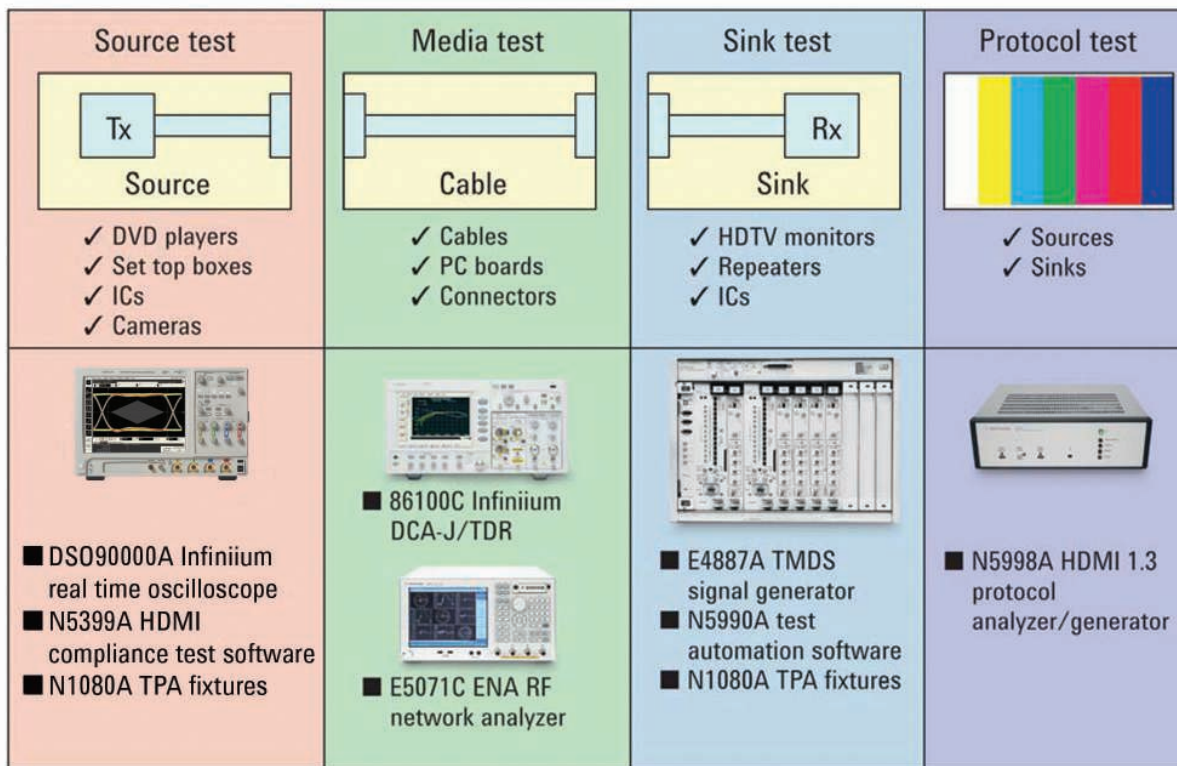

Figure 14.
Keysight HDMI test solutions.

Related Literature

<i>DSO80000B Infiniium Oscilloscope and InfiniiMax Probing System</i>	Data Sheet	5989-4604EN
<i>N5399A HDMI Electrical Characterization and Compliance Software</i>	Data Sheet	5989-3047EN
<i>E4887A TMDs Generator</i>	Data Sheet	5989-5537EN
<i>82150 ParBERT System</i>	Product Overview	5968-9188E
<i>Keysight Technologies Bit Error Ratio Testers</i>	Brochure	5988-9514EN
<i>N5998A HDMI 1.3 Protocol/Audio/Video Analyzer and Generator</i>	Data Sheet	5988-6008EN
<i>86100C Infiniium DCA-J Wide Bandwidth Oscilloscope with TDR</i>	Brochure	5989-5235EN
<i>E5071C ENA RF Network Analyzer</i>	Data Sheet	5989-5479EN
<i>N1080A HDMI Test Point Access Adapters</i>	Data Sheet	5989-5118EN
<i>N5990A Test Automation Software</i>	Data Sheet	5989-5483EN
<i>HDMI Sink and Source Compliance Test and Characterization</i>	Application Note	5989-4959EN

Further information on Keysight's HDMI Measurement solutions can be found online at www.keysight.com/find/hdmi

Have questions about HDMI measurements? Consult the Keysight discussion forum online at www.keysight.com/find/forums

myKeysight

myKeysight

www.keysight.com/find/mykeysight

A personalized view into the information most relevant to you.



www.lxistandard.org

LAN eXtensions for Instruments puts the power of Ethernet and the Web inside your test systems. Keysight is a founding member of the LXI consortium.



Three-Year Warranty

www.keysight.com/find/ThreeYearWarranty

Keysight's commitment to superior product quality and lower total cost of ownership. The only test and measurement company with three-year warranty standard on all instruments, worldwide.



Keysight Assurance Plans

www.keysight.com/find/AssurancePlans

Up to five years of protection and no budgetary surprises to ensure your instruments are operating to specification so you can rely on accurate measurements.

Keysight Channel Partners

www.keysight.com/find/channelpartners

Get the best of both worlds: Keysight's measurement expertise and product breadth, combined with channel partner convenience.

For more information on Keysight Technologies' products, applications or services, please contact your local Keysight office. The complete list is available at: www.keysight.com/find/contactus

Americas

Canada	(877) 894 4414
Brazil	55 11 3351 7010
Mexico	001 800 254 2440
United States	(800) 829 4444

Asia Pacific

Australia	1 800 629 485
China	800 810 0189
Hong Kong	800 938 693
India	1 800 112 929
Japan	0120 (421) 345
Korea	080 769 0800
Malaysia	1 800 888 848
Singapore	1 800 375 8100
Taiwan	0800 047 866
Other AP Countries	(65) 6375 8100

Europe & Middle East

Austria	0800 001122
Belgium	0800 58580
Finland	0800 523252
France	0805 980333
Germany	0800 6270999
Ireland	1800 832700
Israel	1 809 343051
Italy	800 599100
Luxembourg	+32 800 58580
Netherlands	0800 0233200
Russia	8800 5009286
Spain	0800 000154
Sweden	0200 882255
Switzerland	0800 805353
	Opt. 1 (DE)
	Opt. 2 (FR)
	Opt. 3 (IT)
United Kingdom	0800 0260637

For other unlisted countries:
www.keysight.com/find/contactus
 (BP-05-19-14)