



## Agilent EEsof EDA

### Transforms Aid the Design of Practical Filters

This document is owned by Agilent Technologies, but is no longer kept current and may contain obsolete or inaccurate references. We regret any inconvenience this may cause. For the latest information on Agilent's line of EEsof electronic design automation (EDA) products and services, please go to:

**[www.agilent.com/find/eesof](http://www.agilent.com/find/eesof)**

# Transforms Aid the Design of Practical Filters

By **Randall W. Rhea**  
Eagleware Corporation

**F**ilters designed using either direct synthesis or using low-pass prototype tables often have impractical values and are sensitive to component and PWB parasitics. These difficulties are more prevalent in bandpass filters. This article describes how to use transforms to improve filter realizability.

The well-known tee to pi transform is one example of many transforms available. A few of the more useful transforms will be introduced to illustrate how to apply them to solve practical problems.

### Conventional bandpass at narrow bandwidth

Shown in Figure 1 is the schematic of a 3-section 825 to 849 MHz bandpass filter designed by transforming a 0.14 dB ripple Chebyshev low-pass prototype. Conventional cookbook techniques were used to design this filter, as described in numerous references [1].

Notice that the series inductor is extremely large and would be difficult to realize at 800 MHz. In addition, the resulting series capacitor is small, and even a small capacitance to ground for a soldering pad between L2 and C2 would destroy the response of this filter.

Extreme component value ratios are a major problem in the realization of conventional narrow bandpass filters. This occurs because the design process divides the shunt inductors by the loaded  $Q$  and multiplies the series inductors by the loaded  $Q$ . The loaded  $Q$  of this bandpass filter is:

$$Q_{loaded} = \frac{F_o}{BW} = \frac{\sqrt{F_{lower}F_{upper}}}{F_{upper} - F_{lower}} = \frac{836.91}{24} = 34.87$$

### The Norton transform

One of the most useful transforms for filter design is the Norton. The series form is depicted in Table 1 (see Appendix). It replaces a series reactor, which may be an inductor, capacitor or L-C resonator, with three reactors and a transformer. One of the shunt reactors will always be negative. Initially it would seem this transform is not useful but by applying it to this example, we will see it is a powerful tool.

We first apply the series Norton to the series 2357.37 NH inductor in Figure 1 using a turns ratio,  $N$ , equal to 39.64. Using the equations given in Table 1 results in the top schematic in Figure 2. Notice that the series inductor is reduced to 59.47 NH, a much more manageable value. The shunt  $-61.01$  nH inductor has a high-

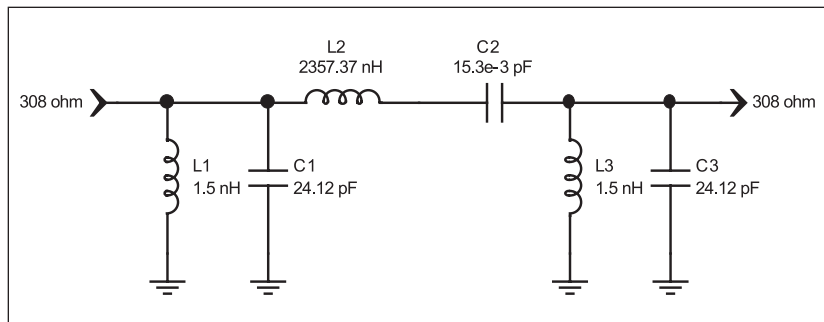

▲ **Figure 1. Schematic of a conventional 3-section bandpass filter from 825 to 849 MHz, with 0.14 dB ripple and 308-ohm source and load terminations.**

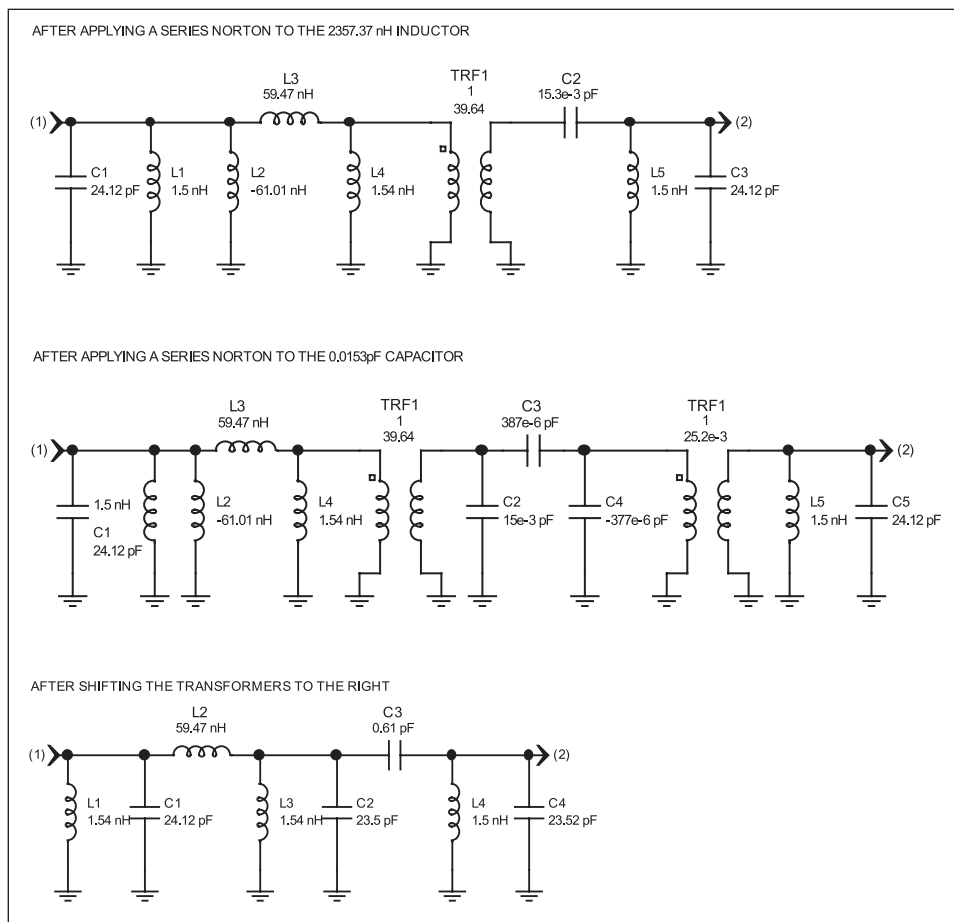

▲ **Figure 2.** Schematic after applying the series Norton transform to L2 in Figure 1 with  $N = 39.64$  (top schematic), after applying the series Norton to C2 in Figure 1 with  $N = 1/39.64 = 0.02523$  (middle schematic) and after shifting the transformers to the right (bottom schematic).

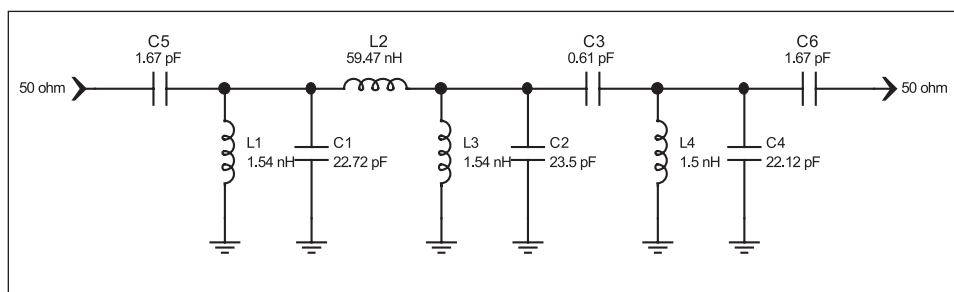

▲ **Figure 3.** Schematic after using series input and output capacitors, so that 50-ohm terminations effectively load the filter internally with 308 ohms.

er reactance than L1 and may be absorbed into L1 thus eliminating the negative inductor.  $N$  was chosen so that the new shunt inductor is similar in value to L1.

Next, we apply a series Norton transform to C2 in Figure 2 using  $N = 1/39.64 = 0.02523$ . The Norton equations operate on the reactance of reactors rather than their values. Because capacitor reactance is inversely proportional to capacitor value,  $1/C$  is used in

these equations. The result is the middle schematic in Figure 2.  $N$  was chosen so that when cascaded the two transformers would cancel.

Finally the first transformer is shifted right until it cancels the second transformer. As the first transformer passes C2, C3 and C4 in the middle schematic of Figure 2 the impedance shift increases their values by  $(39.64)^2 = 1571.32$ . Once the transformer reaches the second transformer, they cancel. The resulting schematic is given at the bottom of Figure 2. The ratio of the largest to the smallest inductor value has been improved by a factor of 39.64. This is a significant improvement in the realizability of this filter. Also notice that every node, where component pads are required, has a capacitor to ground. In the final filter, this capacitance value may be reduced to compensate for the pad capacitance.

For reasons described in the next section, a shunt 1.5 nH inductor was desired for the shunt parallel resonators. The parameters of this filter require that the termination resistances be 308 ohms if the shunt inductors are to be 1.5 nH. The next transform will use series capacitors at the input and output to transform nominal 50 ohms terminations so that 308 ohms is presented to the filter. This transform and defining equations are given in Table 1. The resulting schematic is given in Figure 3.

Other forms of reactance impedance transformers include tapped capacitors and tapped inductors. These techniques are

exact only at the design frequency; however they are useful for bandpass filters because the passband bandwidth is limited.

### A coaxial resonator bandpass filter using lumped/distributed equivalents

Table 1 (see Appendix) shows a transform for replacing a resonant parallel L-C to ground with a grounded

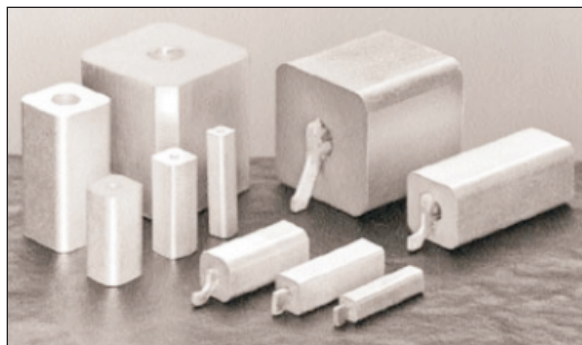

▲ **Figure 4. A family of ceramic-loaded coaxial resonators from Trans-Tech, Inc.**

quarter-wavelength transmission line stub. The characteristic impedance of the transmission line stub is equal to the reactance of the inductor or capacitor multiplied by a factor  $\pi/4$ . A ceramic-loaded coaxial resonator will be used for the stub. A Trans-Tech SP resonator with series 9000 material with a nominal relative dielectric constant of 88.5 has a characteristic impedance of 6.2 ohms is used [2]. A family of Trans-Tech coaxial resonators is shown in Figure 4. When the filter in Figure 1 was designed, using the equations in Table 1, it was determined that the shunt inductor should be approximately 1.5 nH. The terminating impedance was originally set at 308 ohms so that the resulting shunt inductor would be 1.5 nH.

Shown at the top of Figure 5 is the bandpass filter in Figure 3 after transformation of the parallel L-C resonators into transmission line stubs characterized by electrical transmission line parameters. Given at the

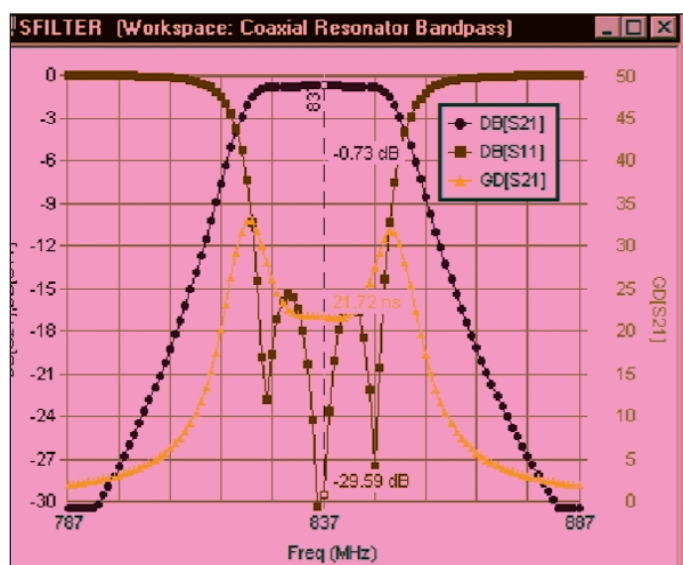

▲ **Figure 6. Computed transmission, return loss and group delay responses of the final 825 to 849 MHz coaxial resonator bandpass filter.**

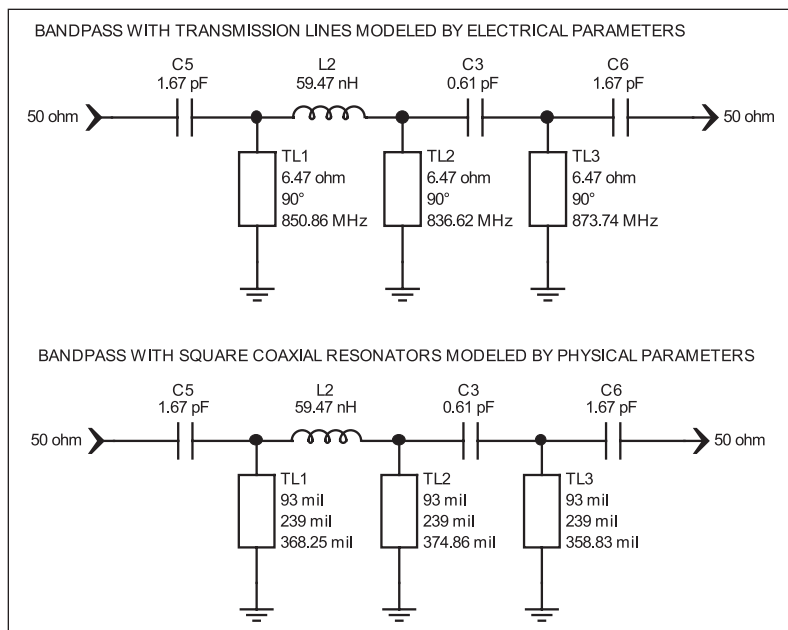

▲ **Figure 5. An 825 to 849 MHz bandpass filter with shunt L-C resonators replaced with equivalent electrical transmission line elements (top) and with physical models for square coax specified by the inner conductor diameter, side dimensions and length in mils (bottom). The physical parameters given are for the Trans-Tech 9000 Series small profile (SP) coaxial resonators.**

bottom of Figure 5 is a schematic after the electrical lines are converted to coaxial resonators described by physical dimensions. Each of the resonators has an inside conductor diameter of 93 mils and an outer side dimension of 239 mils to match the size parameters of a Trans-Tech SP style resonator. The required lengths are 368.25, 374.86 and 358.83 mils respectively.

A final determination of resonator lengths should consider parasitic capacitance for the resonator pins and PWB landing pads. Given in Figure 6 are the amplitude transmission, return loss and group delay responses of the final 825 to 849 MHz bandpass filter computed by the Eagleware GENESYS simulator [3] including mid-band loss predicted by physical models for the coaxial resonators.

### The tubular bandpass

Figure 7 shows a 3-section series resonator 700 to 1000 MHz Chebyshev bandpass filter with 0.05 dB pass-band ripple. Design techniques using inverter transforms for this filter are given in the classic *Microwave Filters, Impedance Matching Networks and Coupling Structures* [4]. These algorithms fail as the passband bandwidth exceeds 20 percent. The bandwidth of this example is:

$$\sqrt{700 \times 1000} / (1000 - 700) = 36.86\%$$

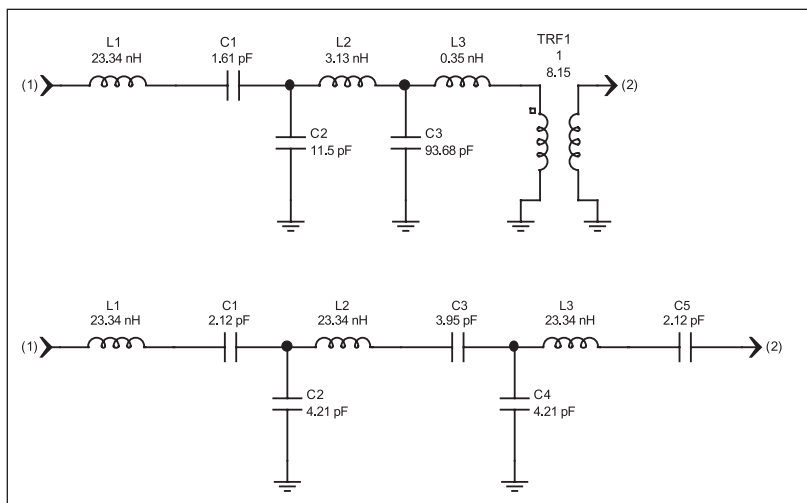

▲ **Figure 7.** A 3-section 700 to 1,000 MHz bandpass filter designed using direct synthesis (top) and then transformed to a pure series-resonator configuration by applying shunt Norton transforms to C2 to place a capacitor in series with L2 and to C4 to place a capacitor in series with L3.

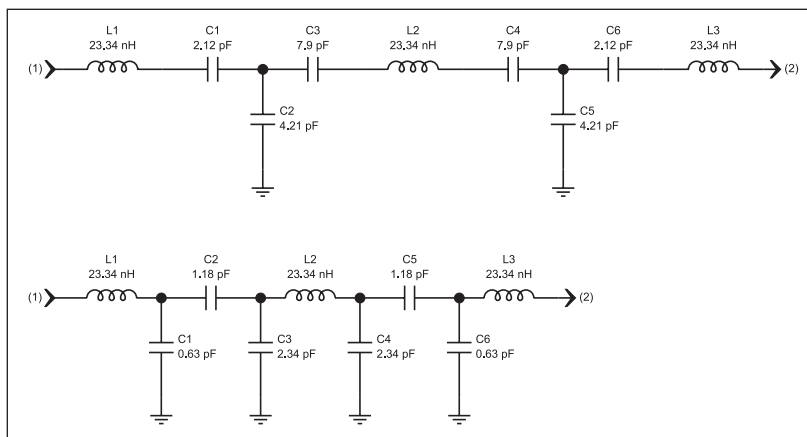

▲ **Figure 8.** The series resonator bandpass shown with the center resonator capacitors split (top) and after applying two tee to pi transforms (bottom).

and the S/FILTER direct synthesis module of GENESYS [3] was used to design this filter. The initial synthesis creates the structure given at the top. Then, shunt Norton transforms are applied to C2 to place a capacitor in series with L2 and to C4 to place a capacitor in series with L3 to create the form at the pure series-resonator form given at the bottom of Figure 7.

Element values are very desirable but the nodes between the series inductors and the series capacitors are susceptible to stray capacitance to ground. To solve this problem we will use the tee to pi transform diagrammed in Table 1. First we must split the center resonator series capacitor to create capacitor tees as shown at the top of Figure 8.



▲ **Figure 9.** Commercial tubular bandpass filters from K&L Microwave (top) and RLC Electronics (bottom).

Next, tee to pi transforms are applied to each tee to create the schematic shown at the bottom of Figure 8. Notice that each node now has a capacitor to ground that may be used to absorb any stray capacitance at that node.

Figure 9 shows a photograph of a commercial tubular bandpass filter, manufactured by K&L Microwave, whose design uses this filter topology [5].

## References

1. R. W. Rhea, *HF Filter Design and Computer Simulation*, Norcross: Noble Publishing, 1994.
2. Trans-Tech, Inc. (a division of Alpha Industries), 5520 Adamstown Road, Adamstown, MD, 21710 ([www.trans-techinc.com](http://www.trans-techinc.com)).
3. GENESYS software suite, Eagleware Corporation, 635 Pinnacle Court, Norcross, GA, 30071 ([www.eagleware.com](http://www.eagleware.com)).
4. G. Matthaei, L. Young and E.M.T. Jones, *Microwave Filters, Impedance Matching Networks and Coupling Structures*, Boston: Artech House, 1980.
5. K&L Microwave, 2250 Northwood Drive, Salisbury, MD, 21801 ([www.klmicrowave.com](http://www.klmicrowave.com)).

## Author information

Randall W. Rhea is the founder of Eagleware Corporation and Noble Publishing Corporation. He received a BSEE from the University of Illinois and a MSEE from Arizona State University. He has been an RF and microwave design engineer for nearly 30 years. He may be reached by Tel: 678-291-0995; or via E-mail: [randy@eagleware.com](mailto:randy@eagleware.com).

## Appendix

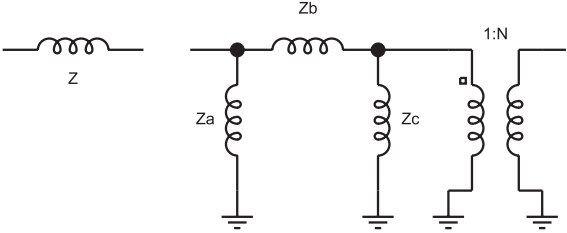
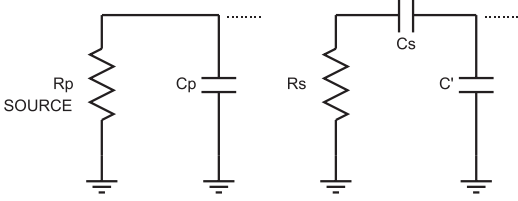
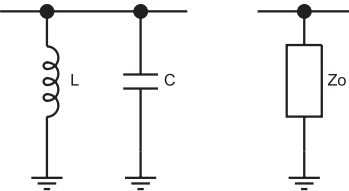
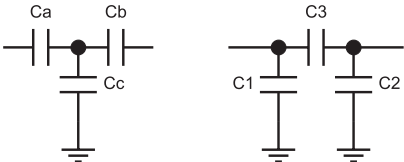
TRANSFORM	EQUATIONS	ACCURACY
<p>NORTON SERIES TRANSFORM</p>  <p>ORIGINAL CIRCUIT</p> <p>TRANSFORMED CIRCUIT Za is negative for N&gt;1 Zc is negative for N&lt;1</p>	$Z_a = \frac{Z}{1-N}$ $Z_b = \frac{Z}{N}$ $Z_c = \frac{Z}{N(N-1)}$ <p><math>N = \text{turns ratio}</math></p>	Exact
<p>SERIES REACTOR IMPEDANCE TRANSFORM</p>  <p>ORIGINAL CIRCUIT</p> <p>TRANSFORMED CIRCUIT Rs&lt;Rp, C'&lt;Cp</p>	$\omega_o = 2\pi F_o$ $X_p'^2 = \frac{R_s R_p^2}{R_p - R_s}, C_p' = \frac{1}{\omega_o X_p'}$ $X_s = \frac{R_p^2 X_p'}{R_p^2 + X_p'^2}, C_s = \frac{1}{\omega_o X_s}$ $C' = C_p - C_p'$	Approximate
<p>LUMPED RESONATOR TO QUARTER-WAVE TRANSMISSION LINE</p> 	$\omega = \frac{1}{\sqrt{L \times C}}$ $Z_o = \frac{\pi \omega L}{4}$ <p><math>length = 90^\circ @ \omega</math></p>	Approximate
<p>TEE TO PI TRANSFORM</p> 	$C_1 = \frac{C_a C_c}{C_a + C_b + C_c}$ $C_2 = \frac{C_b C_c}{C_a + C_b + C_c}$ $C_3 = \frac{C_a C_b}{C_a + C_b + C_c}$	Exact

▲ **Table 1. Transforms used in the examples in this article. These are only a sample of many available transforms. Reference [1] includes additional forms for each transform type and additional types of transforms useful in filter design.**

For more information about Agilent EEs of EDA, visit:

[www.agilent.com/find/eesof](http://www.agilent.com/find/eesof)

 **Agilent Email Updates**

[www.agilent.com/find/emailupdates](http://www.agilent.com/find/emailupdates)  
Get the latest information on the products and applications you select.

 **Agilent Direct**

[www.agilent.com/find/agilentdirect](http://www.agilent.com/find/agilentdirect)  
Quickly choose and use your test equipment solutions with confidence.

**www.agilent.com**

For more information on Agilent Technologies' products, applications or services, please contact your local Agilent office. The complete list is available at:

[www.agilent.com/find/contactus](http://www.agilent.com/find/contactus)

**Americas**

---

Canada	(877) 894-4414
Latin America	305 269 7500
United States	(800) 829-4444

**Asia Pacific**

---

Australia	1 800 629 485
China	800 810 0189
Hong Kong	800 938 693
India	1 800 112 929
Japan	0120 (421) 345
Korea	080 769 0800
Malaysia	1 800 888 848
Singapore	1 800 375 8100
Taiwan	0800 047 866
Thailand	1 800 226 008

**Europe & Middle East**

---

Austria	0820 87 44 11
Belgium	32 (0) 2 404 93 40
Denmark	45 70 13 15 15
Finland	358 (0) 10 855 2100
France	0825 010 700*
	*0.125 €/minute
Germany	01805 24 6333**
	**0.14 €/minute
Ireland	1890 924 204
Israel	972-3-9288-504/544
Italy	39 02 92 60 8484
Netherlands	31 (0) 20 547 2111
Spain	34 (91) 631 3300
Sweden	0200-88 22 55
Switzerland	0800 80 53 53
United Kingdom	44 (0) 118 9276201

Other European Countries:  
[www.agilent.com/find/contactus](http://www.agilent.com/find/contactus)

Revised: March 27, 2008

Product specifications and descriptions in this document subject to change without notice.

© Agilent Technologies, Inc. 2008

Printed in USA, December 01, 2001  
5989-9287EN