

An Overview of WiMAX Radiated Performance Test Requirements

“There is considerable emphasis on making sure that WiMAX technology provides an exceptional user experience out of the box.”

Biographies



Garth D'Abreu, Technical Manager for ETS-Lindgren has primary responsibility for the design and development functions within the RF engineering group. The RF group provides technical support for ETS-Lindgren worldwide and is responsible for anechoic chambers, E Field generators, TEM cell device design and development, antenna design, and absorber development. D'Abreu is the lead engineer for reverberation chamber design and testing and is responsible for the development and support of the immunity and emission chamber control software. He is also responsible for the development of GTEM cells and other test boxes within the RF group and provides technical support to the RF filter, mechanical and project engineering divisions, especially for projects related to EMP systems and special applications. He may be reached at garth.dabreu@ets-lindgren.com.



Sonali Sarpotdar is employed as a Technical Consultant with Agilent Technologies. She specializes in the wireless domain, and is well known for her expertise in this industry. Sarpotdar works with R&D engineers, engaged in the design and development of cellular and datacom devices and base stations, to provide test solutions using Agilent's range of equipment. She has been working in the wireless industry for more than thirteen years. She also conducts trainings and seminars all over the country covering cellular and wireless datacom technologies. She may be reached at sonali_sarpotdar@agilent.com.

At present, more than 500 companies representing all aspects of the WiMAX ecosystem have become members of the WiMAX Forum. The forum is an industry-led, not-for-profit association organized to certify and promote broadband wireless products based upon the harmonized IEEE 802.16/ETSI HiperMAN standard. Member companies are service providers, regulators, equipment manufacturers, test equipment manufacturers, certification labs, and application service providers working together to ensure global adoption of a common platform for the delivery of broadband wireless services. There is a considerable emphasis on making sure that WiMAX technology provides an exceptional, out of the box user experience.

The WiMAX Forum is today the exclusive organization dedicated to certifying the interoperability and performance of products in this ecosystem. Certified products that have been through the process will reduce investment uncertainties for all parties in the wireless access network value chain, from technology providers to service providers to end users. To support the certification test demand, the WiMAX Forum has a network of designated certification laboratories in China, Korea, Spain, Taiwan, and the U.S.

As the world leaders in turnkey systems for wireless performance testing, ETS-Lindgren and Agilent Technologies recognized early on that the WiMAX industry would benefit from over-the-air radiated performance data in much the same way that the wireless carriers have come to rely upon it for the evaluation of phones to be approved for use on their networks. In these ecosystems, a 2 dB loss in radiated performance can result in the need for 25 percent more base stations. With this in mind, radiated performance tests (RPT) for subscriber and mobile stations will become required tests in 2008.¹

Certification Tests

The WiMAX Forum has defined the

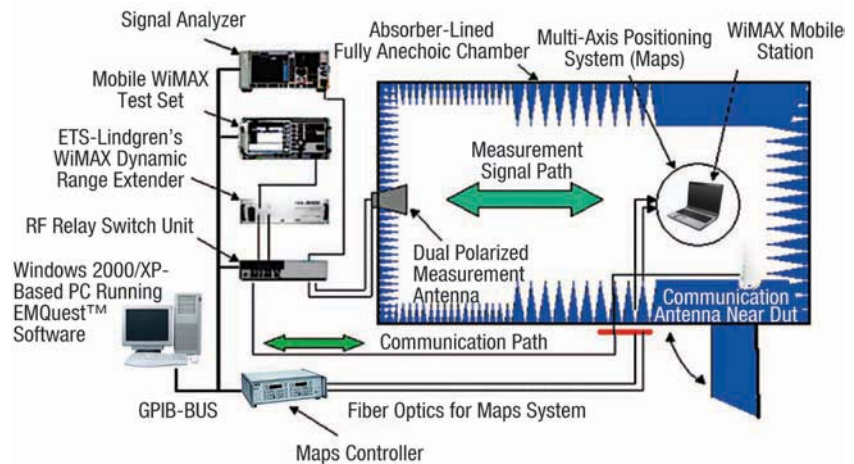

Figure 1: Typical WiMAX RPT test system in a fully compliant rectangular antenna pattern measurement (APM) chamber

required conformance and interoperability tests to ensure that different vendor systems work seamlessly with one another. Those products that pass conformance and interoperability testing are permitted to use the mark WiMAX Forum Certified and may be found listed in the WiMAX Forum Certified Product Registry. There are four required certification tests in this ecosystem:

- Radio Conformance Test (RCT)
 - Protocol Conformance Test (PCT)
 - Interoperability Test (IOT)
 - Radiated Performance Test (RPT)
- The first three tests, RCT, PCT, and IOT, are cable-based tests and are not the subject of this article. The RPT is the focus and it is noteworthy that the test was developed using an ETS-Lindgren solution following more than 18 months of research and development. As a member company, ETS-Lindgren provided principal technical contributions to the creation of the WiMAX Forum Radiated Performance Tests for Subscriber and Mobile Stations.²

There are two primary metrics within the RPT. If you think of this in terms of verbal communication, Total Radiated Power (TRP) is the italkî metric, which measures how loud the device can speak. Total Isotropic Sensitivity (TIS) measures how well the device can hear. Additional detailed information including

time-lapse video of actual tests and three-dimensional radiated pattern measurement data are available at www.WiMAXrpt.com.³

RPT performance parameters to be measured include:

- **Total Radiated Power (TRP)** is the total power radiated by the device under test (DUT) in all directions and is determined by integrating the effective isotropic radiated power (EIRP) over the surface of a sphere surrounding the DUT. It represents the average directional transmit performance of the DUT, accounting for losses due to the efficiency of the antenna and other transmit interaction factors.
- **Total Isotropic Sensitivity (TIS)** or total radiated sensitivity (TRS) is the equivalent sensitivity level of the DUT if it had a theoretical isotropic receiver for an antenna. It is determined by integrating the effective isotropic sensitivity (EIS) over the surface of a sphere surrounding the DUT. It represents the average directional receive performance of the DUT, accounting for losses due to the efficiency of the antenna and other receive interaction factors.

In order to test both these performance parameters, it is necessary to set up a data connection with the DUT. This connection has to be set up to be as close to a real world con-

nection as possible.

Figure 1 shows a system diagram for a recommended WiMAX RPT test system. Note that the system operates in an RF-shielded, absorber lined, fully anechoic test chamber, such as an ETS-Lindgren AMS 8500, or equivalent. Key components of the system are the multi-axis device positioning and controlling mechanism, communication and measurement antennas, measurement instrumentation, and a system computer with data acquisition and analysis software.

Test Chamber Considerations

The type of test facility required to perform OTA (over the air) measurements on a wireless device can be categorized based on whether a *pre-compliant* measurement or a *full certification* type measurement is to be performed. The performance requirement of the chamber differs slightly in either case and has some important cost and performance implications. During the typical OTA measurement of a wireless device, the device under test (DUT) is placed in a controlled space and set to communicate with the instrument used to emulate the base station or LAN. Measurement of the two key perfor-

mance parameters, TRP (total radiated performance) and TIS (total isotropic sensitivity), can then be made from these data sets, while other performance indicators can also be derived.

Chamber OTA performance measurements are specifically concerned with the transmit (TRP) and receive (TIS) properties of the DUT as a whole. The design of the antenna or antennas, the effect of a body in close proximity to the DUT and the effect of the DUT itself on its own radiated performance are all factors that can be determined from measurements made in a suitable test chamber.

The first requirement of the test chamber is to provide RF isolation from the outside world. This ensures that none of the RF energy from other common interfering sources can enter the test area. The test volume should ideally contain energy radiated by the DUT only or by the measurement and communication antenna depending on the type of test being performed. This isolation is achieved by using a shielded room constructed typically of galvanized steel panels bonded together to form an electrically continuous enclosure. The doors, vents, and other penetrations all have to be treated in a man-

ner which maintains the shielding effectiveness of the enclosure. The level of shielding is largely dependent on the type and method of construction of the chamber and the method used to treat these penetrations into the chamber. For performance up to several GHz, a knife-edge type door, waveguide vents, and filters fitted to incoming power and some signal cables are typically required.

To further improve the performance of the chamber and replicate a free field environment, it is necessary to reduce the level of reflected energy in the test volume or quiet zone (QZ). This is achieved by lining the chamber with high performance RF absorber material placed on the walls, ceiling, and floor of the chamber. The RF absorber should have reflectivity performance in excess of 40 dB at the frequencies of interest especially in the specular region of the chamber, and be so oriented that the QZ performance is optimized with any back scattering minimized. In addition to this, any support material used in the chamber, for example polystyrene or polycarbonate, should have a low dielectric loss to minimize overall loss and reflections that could have an adverse effect on the measured pattern.

Figure 1 shows the typical absorber layout in a rectangular Antenna Pattern Measurement (APM) chamber. Figure 2 shows the typical absorber layout in a tapered Antenna Pattern Measurement (APM) chamber. In the rectangular chamber, such as an ETS-Lindgren AMS 8600, or equivalent, the wedge type absorber used on either side of the QZ has similar reflectivity performance to the pyramidal cones of the same size but the wedge profile exhibits less back scatter and is preferred in this location. The large pyramidal absorber, used on the back and side walls, reduces the direct reflection from the back wall into the QZ and the signal incident on the side walls at about 45 degrees.

The smaller 12 inch (305 mm) absorber used on the antenna wall and on the side wall in that region,

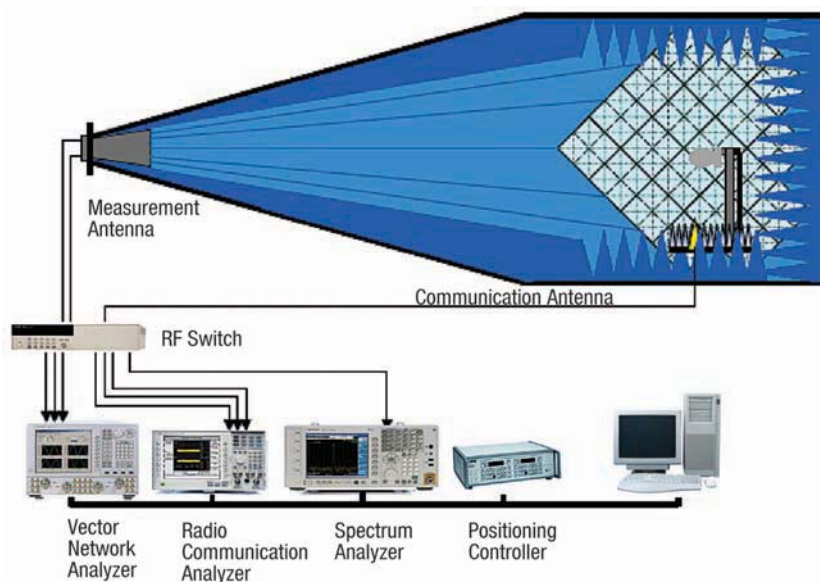

Figure 2. Tapered fully compliant antenna pattern measurement (APM) chamber

is in the area of the chamber where there is less signal from either the measurement antenna or the DUT, the level of signal that can be reflected into the QZ is already much lower, so from the point of view of performance required, the layout is such that the highest performing absorber is placed in the areas where the largest signal will be seen. This reduces cost and provides the largest usable area within the chamber. The chamber length is derived from the distance needed to place the QZ in the far field from the measurement antenna. The tapered chamber has some special properties derived from the extended tapered feed which extends from the source antenna at the apex and aids in the formation of the planar wave front at the QZ, resulting in an extension of the low frequency performance compared to the rectangular chamber. Most of the basic chamber design principles apply for both a pre-compliant and compliant chamber solution. For the pre-compliant measurement, as shown in Figure 3, where a higher measurement uncertainty is tolerable, and available space is a premium, the chamber, such as an ETS-Lindgren AMS 8050, or equivalent, can typically be much smaller with a shorter test distance and use smaller, lower performing absorbers. The same spherical rotation of the DUT could be supported but the QZ ripple is larger and the measurement error also larger as a consequence of the differences in the test layout. The definition of the device's peaks and nulls is affected by the reduced QZ performance and this is an important trade off for the smaller lower cost pre-compliant test solution. A critical component in both chambers is the multi-positioning device needed to support and rotate the DUT or measurement antenna. Measurements can be made at the different orientations of the DUT by either rotating the DUT itself or by moving the measurement antenna relative to the DUT. Both methods result in a spherical plot of the DUT being taken with rotations on the

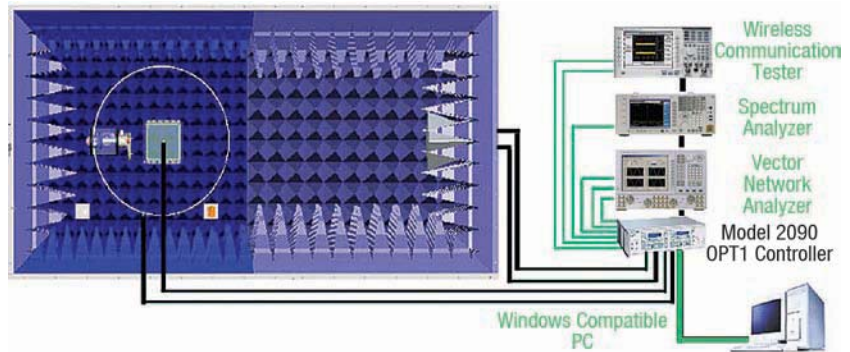

Figure 3. Compact pre-compliance test chamber for OTA measurement

two principal axes as shown in Figure 4. A combined axis or distributed axis system can be used for these orientation changes; the combined axis system is shown here. For the type of 3-D antenna measurements made, the DUT is rotated on its two axes to produce a complete polar plot of the device's performance.

Measurement comparisons made between a fully compliant chamber and the small pre-compliant chamber in the 850/1900 GSM band has shown differences in the measured TIS to be less than 3 dB and in the TRP to be less than 2.5 dB for small hand held devices. Given the significant differences in chamber size and cost, chamber selection is important and should be driven primarily by the required performance and QZ size. Other factors, however, such as available space and budget, often turn out to be the true limiting factors.

Instrumentation Considerations

Following is a brief description of the components of this test system and their function in performing the Radiated Performance Test.

Base Station Emulator: The first component is the 802.16e Base Station Emulator (BSE), such as an Agilent E6651A, or equivalent. It can communicate with the WiMAX Subscriber Station (SS) like a real base station would. The E6651A can be configured to use a number of profiles that use 5 MHz, 7 MHz, 8.75 MHz, and 10 MHz bandwidths and frequencies in multiple bands.

Signal Analyzer: The signal analyzer is an MXA or EXA from Agilent Technologies, or equivalent. It measures the transmitted power from the SS. The output power of a WiMAX subscriber station is generally measured through conductive connection to the signal analyzer. However, the RPT test requires measuring radiated power output from the SS. A special antenna is connected to the signal analyzer for this purpose

Dynamic Range Extender: In RPT tests, the power output required from the BSE is much higher than usual to compensate for path loss during radiation. The ETS-Lindgren dynamic range extender is used to provide sufficient downlink signal strength. The RF relay switch from Agilent is used to switch the various pieces of equipment in and out of the test system as necessary.

Test Methodology

TRP: To measure TRP, it is necessary to measure the power output of the WiMAX Subscriber Station. A data connection has to be established between the BSE and the SS. The first process in this direction is network entry. The SS listens to the downlink frequency to which it has been programmed. It reads the control messaging and synchronizes to the BSE.

The ranging process is used to adjust the frequency, power, and transmit time of the SS. The SS transmits a code in a specific timeslot and the BSE reads it. The BSE then instructs the SS if the frequency ought to be

corrected or if the power and timing need to be adjusted for minimum interference and battery consumption. This is exactly how things work in a real WiMAX network.

In the test system, the BSE allocates resources to the SS for transmission. It also specifies the bandwidth and modulation scheme that the SS should transmit. Measurements can be made on the transmitted data. The BSE also commands the SS to transmit at a specific power level such as maximum power.

This done, a spectrum analyzer in the RPT system may be used to make the power measurement. The Agilent model, for example, has built-in WiMAX specific measurement software. This allows a user to make measurements on a specific portion of the WiMAX burst, such as the control portion or the data portion.

TIS: To measure the sensitivity of a receiver, one of two methods may be used. The BSE could send a data stream to the SS. The SS could be instructed to loop back data at a high power level. The transmitted and received data could then be compared to determine the receiver performance. Alternatively the SS could determine the errors in reception of the data stream and report this figure to the BSE. In WiMAX, the second method is used.

The BSE transmits either 'ping' or 'UDP' packets to the SS. The correct responses from the SS are then counted and the error is calculated. The BSE transmit power is then lowered until the error level reaches 10 percent which is the sensitivity level of the SS. Wave 2 devices can also use the Hybrid ARQ method to test sensitivity. Here the SS sends an ACK or a NACK in response to transmitted packets and these are counted.

Conclusion

The WiMAX Forum has developed a set of radiated performance tests to evaluate the performance of mobile WiMAX devices. The results of these tests will help network opera-

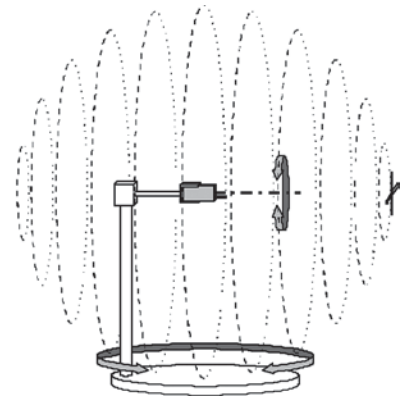
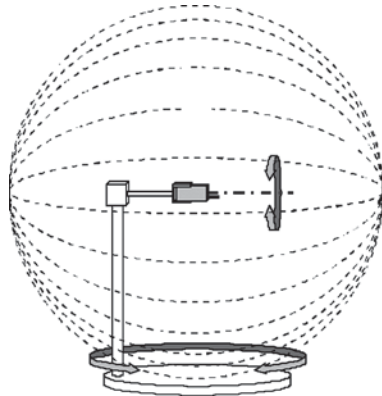

Figure 4. Rotation on two axes to produce spherical data.

tors ensure that WiMAX certified devices operate reliably on their networks. Advantages of using RPT measurements are that a device maker (CPE, handset, etc.) can measure the effect of changes to a product platform, such as the embedded antenna(s), without having to repeat other certification tests on an embedded radio that has already been certified as a "compliant portion". In this way, certification of a device based upon a predicate, where basic components such as display may be changed, is streamlined without concerns as to the impact on device performance. Knowledge of RF performance of base stations, as well as that of the client devices, is essential for good network design. Errors of one or two dB are costly to network layout. Since it's even more costly to add base stations once a network is designed, metrics like TRP and TIS can provide vital information so that a desired level of RF performance can be guaranteed.

To learn more about testing of wireless devices, plan to attend the upcoming Tech Tours hosted by ETS-Lindgren and Agilent Technologies India in Delhi, Hyderabad, and Pune. Technical lectures by industry experts address RF, EMC, and Wireless testing with time allotted for questions and answers as well as demonstrations and refreshments. There is no charge to attend, but pre-registration is required. To reg-

ister, www.tech toursasia.com or call 1800-11-2929 (toll free) and 91-124-2342929, or e-mail: tm_india@agilent.com.

References

- M. D. Foegelle, "Determining Radiated Performance of Mobile WiMAX Devices," *Microwave Journal*, Vol. 51, No. 3, March 2008, pp. 80-92.
- WiMAX Forum Radiated Performance Tests (RPT) for Subscriber and Mobile Stations, V0.1.0 Draft, WiMAX Forum, Beaverton, OR, December 2007.
- B. Saylor, "Executive Interview Series: MJW Speaks with Bryan Saylor," *Microwave Journal*, Vol. 51, No. 3, March 2008, pg. 80 (www.mwjjournal.com).
- "Agilent Technologies, ETS-Lindgren Test Equipment Selected by AT4 wireless for Use in First Test Facility for WiMAX Radiated Performance Test," www.forbes.com, January 10, 2008.
- M.D. Foegelle, "Antenna Pattern Measurement: Concepts and Techniques," *Compliance Engineering*, 2002 Annual Reference Guide, Vol. XIX, No. 3, pp. 22-33.
- M. D. Foegelle, "Radiated Performance Testing of WiMAX Mobile Devices," *Wireless Design Magazine*, March 2008, pp. 16-18.
- Agilent Technologies, Application note, "Mobile WiMAX PHY Layer (RF) Operation and Measurement", literature number 5989-8309EN. ■

Product specifications and descriptions
in this document subject to change
without notice

© Agilent Technologies 2008
Printed in USA, December 1, 2008
5990-3732EN