

Keysight Technologies

Achieve Accurate Resistance Measurements with the 34980A Multifunction Switch Measure Unit

Application Note





Introduction

When you make multiple resistance measurements, accuracy can be improved with compensation and control. This is particularly true when resistance values being measured become very small or when small changes in resistance need to be detected. This Application Note offers several options to help you make accurate low resistance measurements. It provides a basic overview of how to ensure accurate 2-wire, 3-wire and 4-wire measurements with the Keysight 34980A Multifunction Switch/Measure unit with built-in digital multimeter (DMM) and a plug-in multiplexer module.

The Challenge of Two-Wire Resistance Measurements

Two-wire resistance measurements are the simplest to make. After all, what test engineer has not picked up a handheld ohm meter to make this measurement? This basic concept can be extended to making multiple measurements by using a 2-wire multiplexer such as the Keysight 34980A Multifunction Switch/Measure unit with built-in DMM and a 2-wire multiplexer module like the 34921A or the 34922A.

The drawing at Figure 2 shows an unknown resistance connected to an ohm meter through a multiplexer and a length of wire. In addition to the unknown resistance (R_{unknown}), the resistance of the lead wires (RL) and the contact resistance of any closed relays (RR) equal the total resistance measured. In applications where the unknown resistance is relatively high or where accuracy requirements are low, a two-wire measurement may be acceptable.

The plot at Figure 3, shows how the error in the measurement changes as the value of R_{unknown} becomes smaller. The additional resistance of the lead length and relay causes a resistance error that becomes substantial as R_{unknown} is similar to $RL + RR$.

A reference resistor ($R_{\text{reference}}$) can also be used to compensate for relay resistance and the lead length. The reference resistor may be of a similar value to R_{unknown} and should be located such that lead lengths are comparable. The technique involves measuring the reference resistor, calculating an error based on deviation from the known value and using this error to compensate the measurement of R_{unknown} . Corrections are typically made in software after making sequential measurement of R_{unknown} and $R_{\text{reference}}$.

The technique is best applied in situations where a 2-wire system is in place and there is a desire to improve accuracy without making substantial changes. The reference resistor could be a low value or even a short in some situations. The key is to have a trusted reference that is relatively insensitive to environmental factors and on the same order of the R_{unknown} value to provide a trusted measurement. This technique should be validated before relying on measurement results.

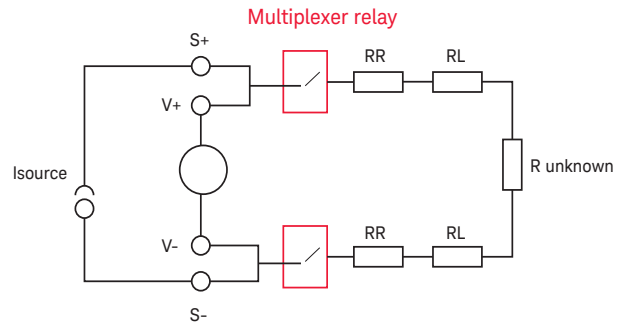

Figure 2. Two-wire technique where RR is the relay contact resistance and RL is the lead resistance. R is the resistance to be measured.

2 Wire Error

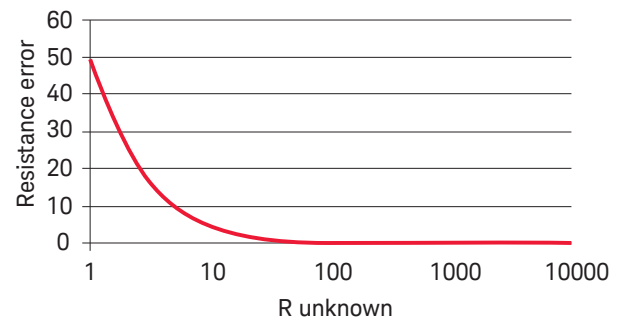

Figure 3. Two-wire error.

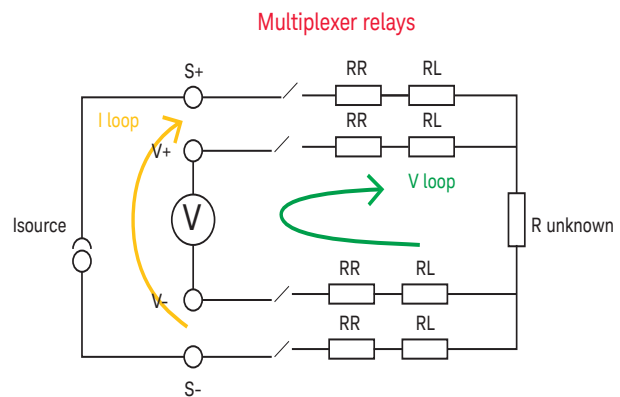

Figure 4. 4-wire technique where one loop provides current to R_{unknown} , creating a voltage drop, measured in the low current V loop. The current in the V loop is small due to the high impedance of the voltmeter, therefore RR and RL can be neglected and R_{unknown} is accurately measured.

Benefits of a 4-Wire Technique

A more accurate way to determine a resistance value is to use 4-wire rather than a 2-wire measurement. The 4-wire technique uses a pair of current source wires and a pair of voltage sensing wires in parallel, as shown in Figure 4, on the previous page. The current source wires generate a voltage drop across R_{unknown} along the lead wires and relay wires. Since current is constant, the voltage drop across R_{unknown} is completely dependent upon the current and its value. The current source tends to be of a high accuracy and constant contributing to high accuracy and precision. A second pair of wires forms a voltage loop that is used to measure the voltage drop across R_{unknown} . Since the resistance of the voltmeter is very high (on the order of 10M ohms), the lead wire R_L and relays R_R resistance have little effect on the measurement. The accuracy is independent of R_{unknown} and is typically more than 1,000 times improved over the 2-wire method. The 4-wire technique clearly shows the genius that Lord Kelvin demonstrated in 1855.

External Current Sources

When making resistance measurements, current is typically limited to reduce i^2R heating. For the 34980A, the maximum current is 1mA. In some cases, the 1mA may need to be reduced to avoid heating of sensitive resistors or sensors, or may need to be increased to improve detection of small voltages. In these cases, an external current source may be used. An external current source should be precise and stable for best outcomes. Sometimes, these conditions cannot be readily achieved and a reference resistor is employed to determine the current. When used, the voltage across the reference resistor can be directed to the voltmeter using the multiplexer followed by a measurement of the voltage across R_{unknown} . The two measurements can then be used to calculate R_{unknown} .

Compromises Using the 3-Wire Technique

To reduce measurement cost, as compared to the 4-wire approach, it is possible to use a 3-wire configuration as shown in Figure 5. Older test instruments used Wheatstone bridge input circuits, dedicated to measuring 3-wire devices. Modern DMMs such as the one built-in the 34980A are not limited by the older circuit design and offer the more accurate 4-wire measurements. While 3-wire resistance measurements do not compensate as well as the 4-wire technique, measurement accuracy is better than with the 2-wire measurement.

RTD sensors

Resistive Thermal Devices (RTD) are sensors whose resistance is roughly linear dependent on temperature as show in Figure 6. These sensors are commonly measured with the 3-wire technique because they are 3-wire devices. An expected RTD resistance is 100 Ω (or 1,000 ohms) at 0°C and has a temperature sensitivity of either 0.00385 ohms/ohm/C (European curve) or 0.00392 ohms/ohm/C (American curve). The 34980A DMM supports both curves.

Today, because of the low resistance and desire to maximize accuracy, a 4-wire technique is most often used. Note that additional accuracy can be achieved by using the Callendar-Van Dusen equation to further correct for non-linearity. See *Practical Temperature Measurements - Application Note*, literature number 5965-7822E for more details and for thermocouple and thermistor temperature measurement details.

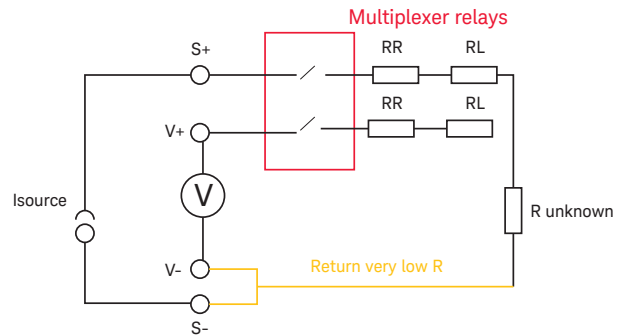

Figure 5. Three-wire technique.

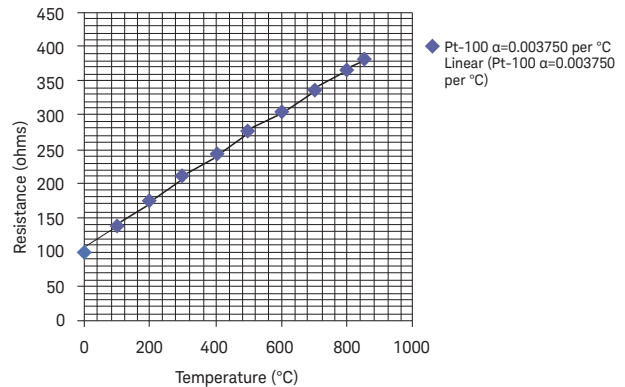

Figure 6. Linear (pt-100 $\alpha = 0.00385$ per $^{\circ}\text{C}$)

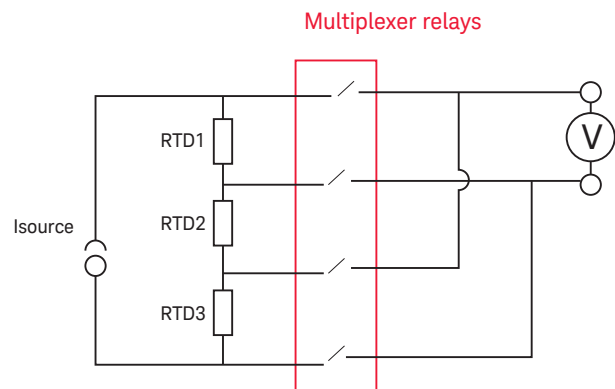

Figure 7. Series RTD configuration with external current source.

Another way to make RTD measurements is shown in Figure 7 on the previous page. Here, a number of RTD's are placed in series and driven by a precision current source. The voltage drop across each can be measured through a multiplexer. This is a pseudo 4-wire system where resistance errors due to the multiplexer relays and associated leads are minimized.

Consider Resistance from Relay Contacts

At first glance, an electromechanical or amature relay seems to be a fairly simple device where the closed contact resistance is assumed to be insignificant. The reality, however, is that contact resistance is dependent on and can change due to current, the number of relay actuations and age. The nature of the problem can be appreciated by considering that relays operate by pulling together a set of metal contacts that are contained in some type of case. The materials of construction and the nature of the environment drive the quality of the electrical contact, as shown in Figure 8.

While the materials used for relay contacts have substantially advanced, there are still tradeoffs that effect relay performance. Common concerns with the relay contacts are fretting, oxidation, contamination and electromigration.

Fretting is the removal of materials due to the repeated closure of contacts. It is essentially a wear out mechanism that leads to surface asperities and pitting. The change in profile limits contact areas and increases resistance. Oxidation of the contacts can also occur. Since oxides are typically poor conductors, this also leads to increased resistance. Contacts can become contaminated from out gassing of the housing and materials used in relay construction. Humidity can also infiltrate the relay housing and contaminate or oxidize contact surfaces. Excessive voltage or currents will also degrade contacts. For this reason, test engineers must be aware of the possibility of additional resistance from relay contacts when using electromechanical relays.

Multiplexer Basics

Multiplexers utilize a matrix of relays that sequentially present the resistance to be measured to the measuring device - in this case, the 34980A's built-in DMM. In general, the interconnection between relays to the 34980A are very stable and very low in resistance. The main contributor to resistance measurement error is the relay contacts.

Conclusion

There are several options available for making resistance measurements. For low cost resistance measurements that have high resistance values or do not need to be highly accurate, the simple 2-wire resistance measurement can be used. When making multiple resistance measurements or multiplexing, this requires less cabling to-from the device under test (DUT) and DMM which requires only one channel pair for each measurement.

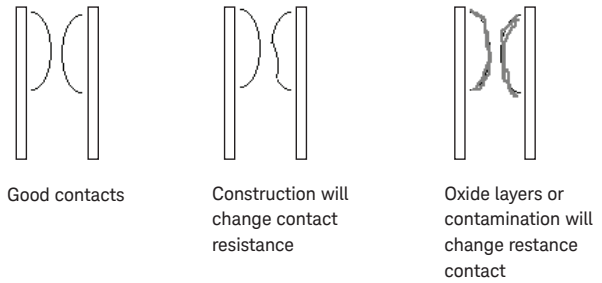

Figure 8. Relay contacts.

When more accurate measurements are needed, the 4-wire technique is recommended. The 4-wire technique provides the highest resistance measurement accuracy by eliminating all internal path resistance and DUT lead resistance. Using a 4-wire technique typically requires two channels for each measurement. However, an alternative technique is described in *Achieve Accurate 2-Wire Resistance Measurements with the Keysight 34923A and 34924A Multiplexers - Application Note*, literature number 5991-2332EN.

Using a multiplexer in precision resistance measurement applications has some challenges over making single point measurements. In addition to considering the value of the resistance to be measured, lead resistance and i^2R heating, the test engineer will need to take into account the multiplexer configuration and relay performance. There may also be a compromise between the number of multiplexer channels and the precision of the resistance measurement.

Additional Resources

Description	Pub Number
<i>Practical Temperature Measurements Application Note</i>	5965-7822E
<i>Achieve Accurate 2-Wire Resistance Measurements with the Keysight 34923A & 34924A Multiplexers Application Note</i>	5991-2332EN
<i>34980A Measurements Made Easy Application Note</i>	5991-1464EN
<i>34980A Multifunction Switch/Measure Unit Data Sheet</i>	5990-1437EN
<i>Keysight PXI and AXIe Modular Catalog</i>	5990-7367EN

Configuration and Ordering Information

Ordering Information

Model	Description	
Mainframe - holds up to 8 plug-in modules		
34980A	Multifunction switch/measure mainframe	Comes standard with "DMM" option, BenchLink data logger software, user guide on CD-ROM, power cord and quickstart package.
34832A	BenchLink data logger pro software	Upgrade your complimentary software package to add limit checking and decision making for more complex applications.
Multiplexer modules		
	Module connectors	Optional terminal blocks, cables, connector kits
34923A	40/80 channel reed multiplexer	2- 50 pin Dsub, Male
		3492xT Terminal block with screw connectors Y1135A - 1.5 m 50-pin M/F Dsub cable Y1136A - 3 m 50-pin M/F Dsub cable Y1139A - 50-pin female solder cup connector kit
34924A	70 channel reed multiplexer	2- 78 pin Dsub, Male
		3492xT Terminal block, option 001 for solder connections, option 002 for screw connectors Y1137A - 1.5 m 78-pin M/F Dsub cable Y1138A - 3 m 78-pin M/F Dsub cable Y1140A - 78-pin female solder cup connector kit

Software Information

Supported operating systems	Microsoft Windows 98 SE/NT/2000/XP
Software drivers	IVI-C and IVI-COM for Windows NT/2000/XP Labview
Compatible programming tools and environments	Keysight VEE Pro, Keysight T&M toolkit (requires Visual Studio.NET) National Instruments Test Stand, Measurement Studio, LabWindows/CVI, Labview, Switch Executive Microsoft Visual Studio.NET, C/C++, Visual Basic 6
Keysight IO Libraries	Version 14 or greater
Keysight BenchLink data logger software	
Operating system	Windows 2000 SP4, XP SP2
Controller	Recommended: Pentium 4, 800 MHz or greater, minimum: Pentium III, 500 MHz

For a complete list of plug in modules and accessories for the 34980A, please refer to the datasheet, literature number 5989-1437EN.

Evolving

Our unique combination of hardware, software, support, and people can help you reach your next breakthrough. **We are unlocking the future of technology.**



From Hewlett-Packard to Agilent to Keysight

myKeysight

myKeysight

www.keysight.com/find/mykeysight

A personalized view into the information most relevant to you.

KEYSIGHT SERVICES

Accelerate Technology Adoption.
Lower costs.

Keysight Services

www.keysight.com/find/service

Our deep offering in design, test, and measurement services deploys an industry-leading array of people, processes, and tools. The result? We help you implement new technologies and engineer improved processes that lower costs.



www.axiestandard.org

AdvancedTCA® Extensions for Instrumentation and Test (AXIe) is an open standard that extends the AdvancedTCA for general purpose and semiconductor test. The business that became Keysight was a founding member of the AXIe consortium. ATCA®, AdvancedTCA®, and the ATCA logo are registered US trademarks of the PCI Industrial Computer Manufacturers Group.



www.pcisig.com

PCI-SIG®, PCIe® and the PCI Express® are US registered trademarks and/or service marks of PCI-SIG.



Three-Year Warranty

www.keysight.com/find/ThreeYearWarranty

Keysight's committed to superior product quality and lower total cost of ownership. Keysight is the only test and measurement company with three-year warranty standard on all instruments, worldwide. And, we provide a one-year warranty on many accessories, calibration devices, systems and custom products.

Keysight Channel Partners

www.keysight.com/find/channelpartners

Get the best of both worlds: Keysight's measurement expertise and product breadth, combined with channel partner convenience.

PICMG and the PICMG logo; CompactPCI and the CompactPCI logo; ATCA, AdvancedTCA, and the ATCA logo are registered US trademarks of the PCI Industrial Computer Manufacturers Group.

www.keysight.com/find/modular

www.keysight.com/find/34980a

For more information on Keysight Technologies' products, applications or services, please contact your local Keysight office. The complete list is available at: www.keysight.com/find/contactus

Americas

Canada	(877) 894 4414
Brazil	55 11 3351 7010
Mexico	001 800 254 2440
United States	(800) 829 4444

Asia Pacific

Australia	1 800 629 485
China	800 810 0189
Hong Kong	800 938 693
India	1 800 11 2626
Japan	0120 (421) 345
Korea	080 769 0800
Malaysia	1 800 888 848
Singapore	1 800 375 8100
Taiwan	0800 047 866
Other AP Countries	(65) 6375 8100

Europe & Middle East

Austria	0800 001122
Belgium	0800 58580
Finland	0800 523252
France	0805 980333
Germany	0800 6270999
Ireland	1800 832700
Israel	1 809 343051
Italy	800 599100
Luxembourg	+32 800 58580
Netherlands	0800 0233200
Russia	8800 5009286
Spain	800 000154
Sweden	0200 882255
Switzerland	0800 805353
	Opt. 1 (DE)
	Opt. 2 (FR)
	Opt. 3 (IT)
United Kingdom	0800 0260637

For other unlisted countries:
www.keysight.com/find/contactus
(BP-2-23-17)



www.keysight.com/go/quality

Keysight Technologies, Inc.
DEKRA Certified ISO 9001:2015
Quality Management System



Unlocking Measurement Insights

This information is subject to change without notice.
© Keysight Technologies, 2012 - 2017
Published in USA, May 16, 2017
5991-2788EN
www.keysight.com