



# 10 Things You Must Know Before Buying Your Next Benchtop Digital Multimeter

eBook

 KEYSIGHT

## INTRODUCTION

The digital multimeter (DMM) is the most commonly used instrument on an engineer's bench. We use it almost every day. Whether we are making a quick and simple voltage measurement or data logging temperature over a long period of time, our DMM just has to work. It is the workhorse of the engineering bench. In many ways, most of us are in a one-sided relationship with our DMMs. In exchange for all the work that it does, we expect very little maintenance and upkeep from our end in return. Even though the DMM is such an important instrument, we do not spend nearly enough time thinking about it. From concept to prototype turn-on and debugging all the way through testing and validation, the DMM is ever-present through the entire product cycle from beginning to end. This eBook will take a closer look at the DMM and all that it does. We will explore 10 things that you should know about DMMs. The topics covered are applicable whether you are considering your next DMM purchase or you want to get more from the DMM currently on your bench.





# Contents



## CHAPTER 1

# Bench vs. Handheld



# Bench vs. Handheld

This eBook will focus exclusively on bench DMMs. We will not cover handheld DMMs in this eBook, however, keep in mind that many of the concepts that we cover for bench DMMs also apply to handheld DMMs. In general, bench DMMs have higher accuracy, better resolution, enhanced system programmability, and 4-wire measurement functionality compared to a handheld DMM. Handheld DMMs tend to provide lower accuracy and offer simpler functionalities. They also tend to be more portable and used in a standalone fashion most of the time. Many technicians and electricians use handheld DMMs because of their portability. Many engineers and designers prefer bench DMMs for their accuracy and broad measurement capabilities.

Some handheld DMMs offer *Bluetooth*® connectivity and mobile application. On the other hand, bench DMMs typically offer wired connectivity options such as LAN, USB, or GPIB. This allows for automated testing and integration into a test rack. It also allows for PC software application and custom programs to control the DMM. If automated testing and remote programming are extremely critical in your use model, the bench DMM is probably the best option. In addition, since bench DMMs are less portable in nature, they tend to stay on your bench a lot longer because it is more difficult for a colleague to borrow.

In the rest of this eBook, the term DMM will specifically refer to bench DMMs, not handheld DMMs.





## CHAPTER 2

# Digits, Accuracy, Resolution



## Digits, Accuracy, Resolution

To understand digits, accuracy, and resolution, we begin by asking the most common DMM question: what's that half digit? Users ask this question frequently, so it is important to understand the importance of the half digit. It is actually the first spec you will notice about a DMM. If you have a 3 and a half digit DMM, the half digit is the most significant **digit**.

3 ½ digits	+/- 1999	2,000 counts
4 ½ digits	+/- 19999	20,000 counts
5 ½ digits	+/- 199999	200,000 counts
6 ½ digits	+/- 1999999	2,000,000 counts

The half digit can only be a 0 or 1. So a 3 and a half digit DMM offers plus or minus 2,000 counts. A 4 and a half digit DMM offers plus or minus 20,000 counts and so on. The number of digits directly translate to the number of counts. Digits and counts give us an idea of the resolution of a DMM. They are not directly related to accuracy. It is a common misconception that digits and counts are the accuracy of a DMM.





## CHAPTER 3

# Visualization





# Visualization

One of the key considerations when selecting a DMM is how it graphically displays the data. How do you want to see your data? Most DMMs will have a default numerical display. However, advanced DMMs also have sophisticated features like trend charts (value vs. time) and histograms. Some will return digitized value over the I/O port. On a crowded bench, it is important to have a DMM that stands out and displays its measurements in a clear and easy to read manner.



The Keysight Technologies Truevolt series of DMMs offers graphic capabilities such as trend and histogram charts allowing for quick insight into the measurement. The 4.3-inch color graphical display makes monitor and statistical analysis easy and intuitive.

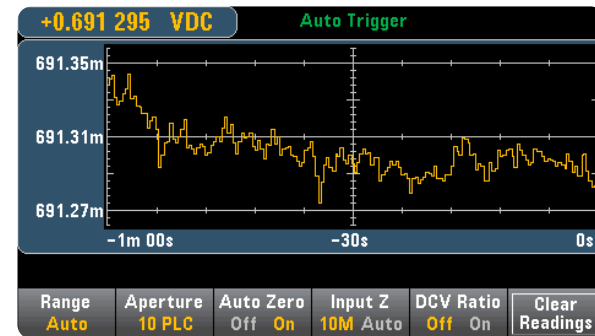

Trend chart display on the Keysight Truevolt DMM

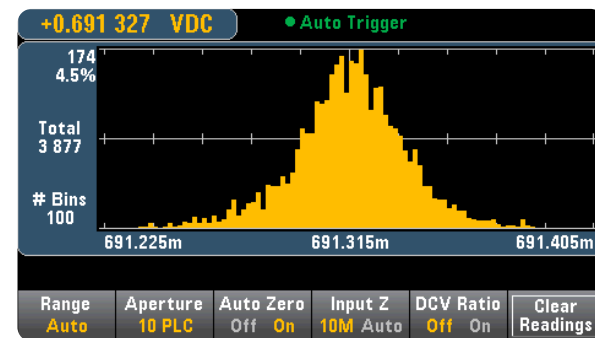

Histogram chart display on the Keysight Truevolt DMM



Secondary measurement display on the Keysight Truevolt DMM



## CHAPTER 4

# Secondary Measurements

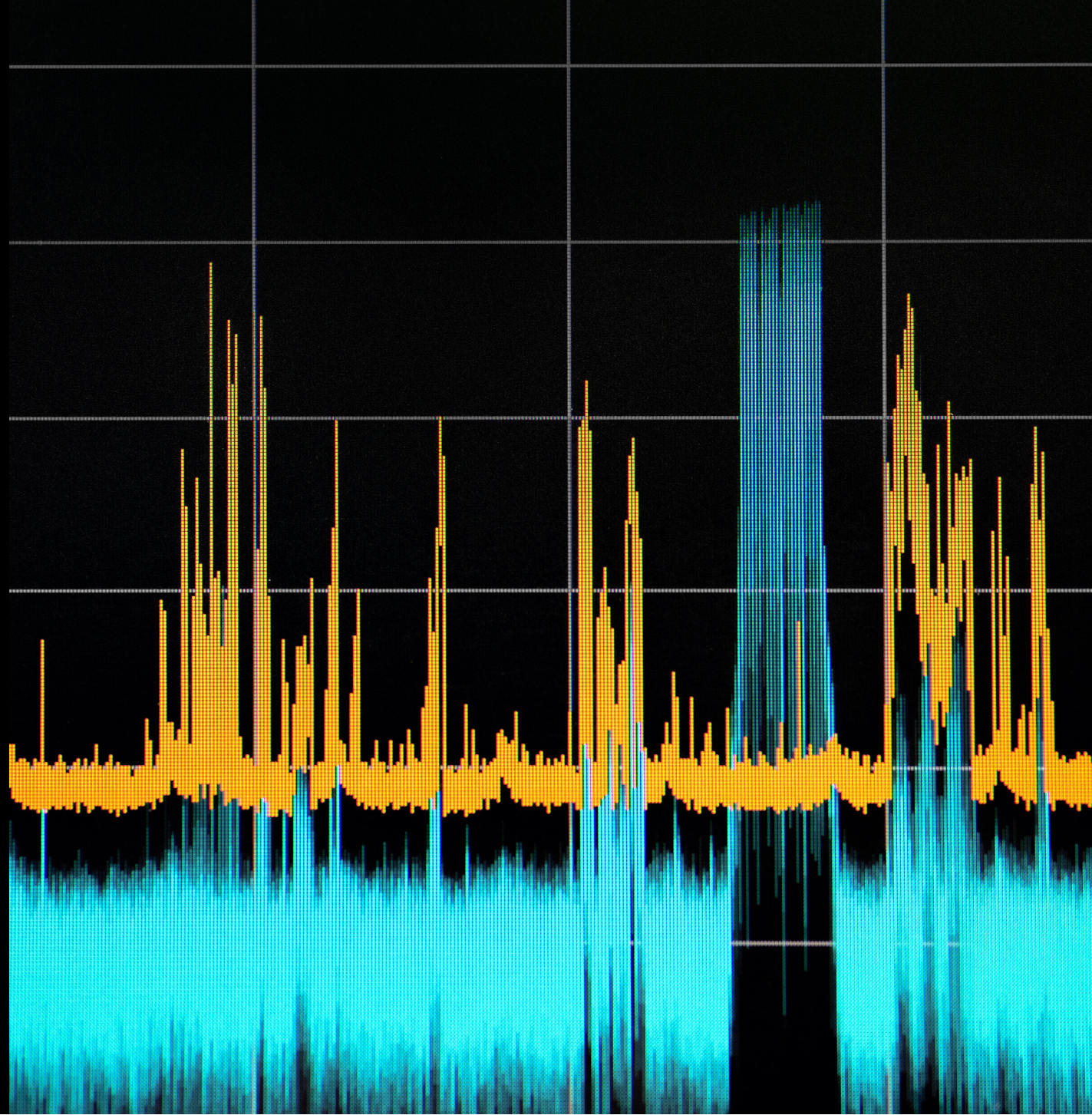

# Secondary Measurements

Traditionally, digital multimeters (DMMs) have been single-measurement instruments. In some cases, however, system designers want the ability to track more than one parameter on a signal. This provides complementary data that can make measurements significantly easier to understand. With the right architecture and design, DMMs can now make secondary measurements. One example where this might be useful is when measuring temperature using a thermistor connected to a DMM. If there is a discrepancy in the temperature readings, an engineer might be interested in simultaneously monitoring the resistance of the temperature sensor to make sure it is within range.

Another example is when measuring a noisy signal, an engineer might be interested in looking at both the DC and AC component at the same time. This table shows a list of the secondary measurement functions available on the Keysight Truevolt series of DMMs.

Primary measurement functions	34460A secondary measurement functions	34465A/70A secondary measurement function
DCV	ACV	ACV, peak, pre-math
ACV	Frequency	DCV, frequency, pre-math
2 wire, 4-wire resistance		Pre-math
DCI	ACI	ACI, peak, pre-math
ACI	Frequency	DCI, frequency, pre-math
Frequency	Period	Period, ACV, pre-math
Period	Frequency	Frequency, ACV, pre-math
Temperature	Sensor	Sensor, pre-math
Ratio	Input/Ref	Input/ref, pre-math
Capacitance		Pre-math
Continuity		None
Diode		None



Secondary measurement display on the Keysight Truevolt DMM



## CHAPTER 5

# Simple DC Power Measurement



# Simple DC Power Measurements

Many applications require power measurements. For many years, the DMM has traditionally been the instrument to rely on when measuring power since not everyone has a power meter on their bench. While DMMs can measure both current and voltage, their internal design topology prevents them from measuring both at exactly the same time. Using a few different techniques, however, you might be able to get a good V/I measurement from your benchtop DMM. One technique is to use a math function. If you know the voltage is going to remain pretty steady, then you can program your DMM to multiply the known (previously measured) voltage value by the measured current value. Power equals voltage multiplied by current, so you will get a power value in watts displayed on the DMM. Another method is the simultaneous measurement of voltage and current.

The Keysight Truevolt DMM has a special feature to obtain simultaneous voltage and current readings. If the sense terminals are not in operation, you can use them to make a secondary voltage measurement in a circuit while the primary terminals are measuring across a 1 ohm resistor in series with the circuit. This gives you a simultaneous voltage and current measurements. Some restrictions do apply, but for basic power measurements, it is a handy feature.

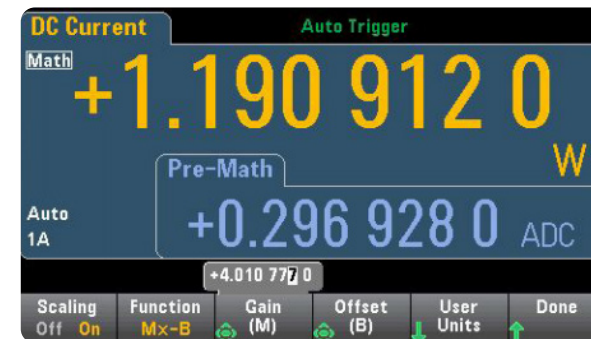
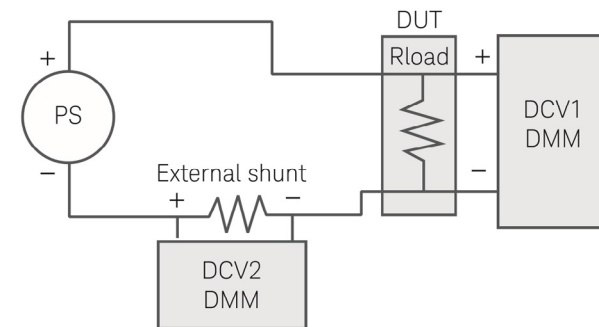
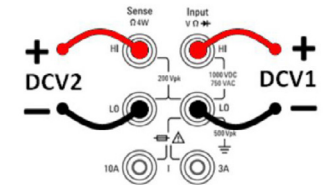



## CHAPTER 6

# Low Current & Dynamic Current Measurements

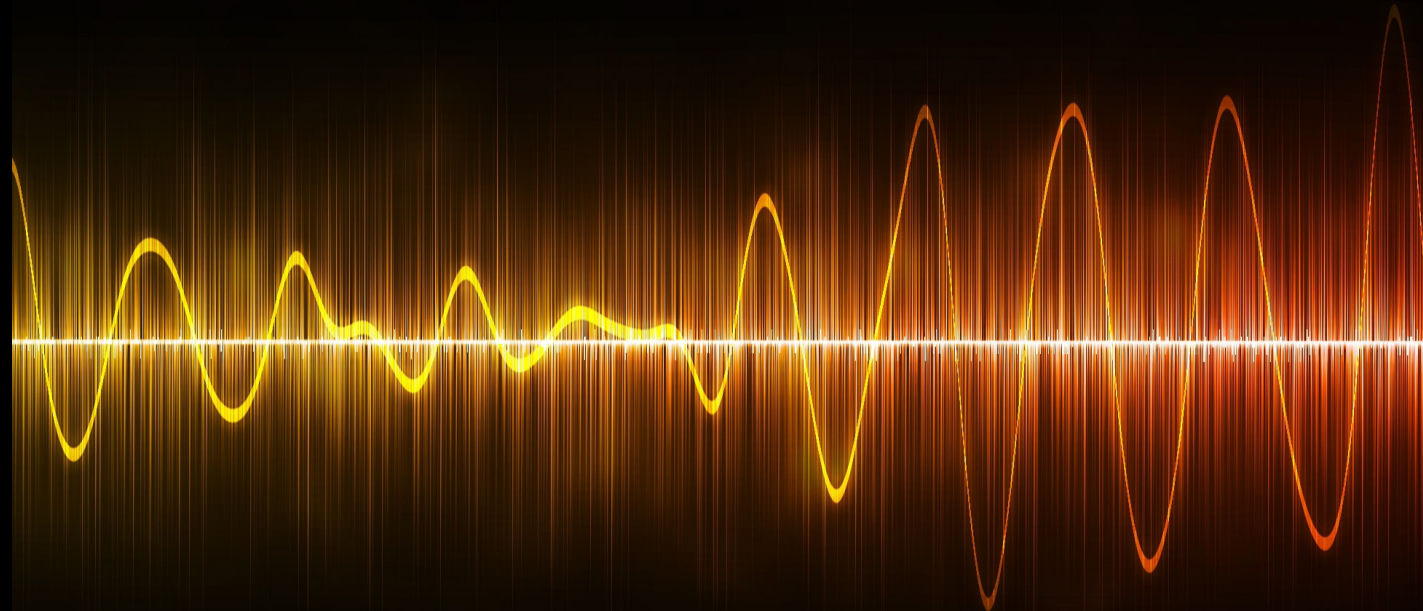

# Low Current & Dynamic Current Measurements

When selecting your next DMM, consider the range of current measurements you need to perform. Measuring current on a semiconductor device requires a much higher level of current measurement accuracy compared to other applications. Most 6 and a half digit DMMs are limited to a 1 mA low current range. Burden voltage can be an issue when measuring low current. Burden voltage is the voltage across a shunt resistor in series with a circuit. Burden voltage is a concern when you want to measure very sensitive components. You might be able to offset the burden voltage by setting the voltage slightly higher on your power source. The newer Keysight DMMs have a much better design for measuring low current. The 34470A 7 1/2 digit DMM has a much lower burden voltage compared to the industry standard [Keysight 3458A 8 1/2 digit DMM](#).

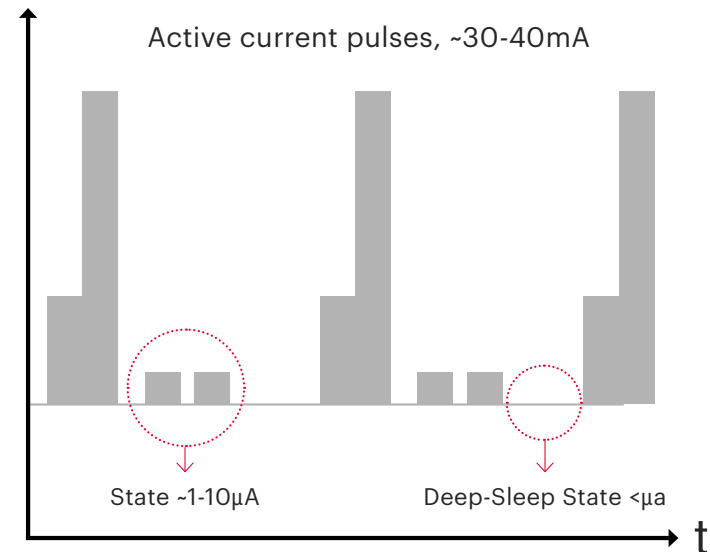
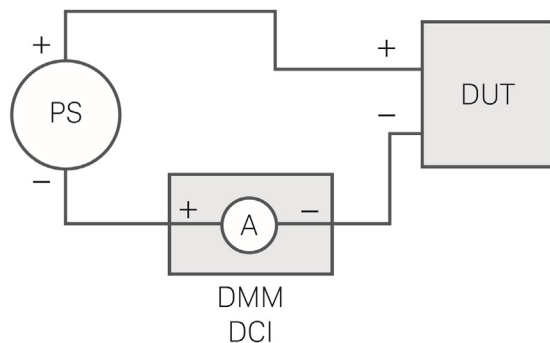

Dynamic current measurements can be quite complicated, especially when it involves a change in measurement range. The image above shows a typical current profile of a portable radio transceiver. The current draw here depicts a wide range of sleep, standby and active modes. The dynamic range of the current is large because the operating currents are drawing approximately 30 to 40 mA, while the standby currents are only 1 to 10 µA. To get accurate readings for both ranges with a DMM, you need to take multiple reading sweeps with different ranges. One method for capturing the current profile would be to run the device many times to capture the sleep and standby modes separately and, then measure the operating mode currents. It is also worth noting that most DMM measurements are not seamless even if they are autoranging. This means a DMM will typically miss measurement points on a fast dynamically changing current waveform.



## CHAPTER 7

# Measuring Difficult AC Signals





# Measuring Difficult AC Signals

When thinking about an AC voltage signal, we typically picture a perfect sinusoidal waveform. In the real world, however, AC voltage signals and currents are never perfect. They come in widely varying shapes and values. While digitizing waveforms allow you to see a few cycles, if you are interested in the RMS amplitude or frequency of your AC waveform over time, you'll need to make AC measurements. An important component to this measurement is the crest factor. For a measuring instrument, the crest factor... The crest factor is the ratio of peak value to RMS value in a waveform. A DMM's crest factor represents how much of the total energy from the peak value will be included in an AC measurement. Ideally, you would like to include as much of the total energy in the waveform as possible to get an accurate measurement. The crest factor expresses the size of the dynamic range of an input signal. We define the crest factor as the peak of the dynamic range based on the rated range value (RMS value). If a DMM has a crest factor rating of 10, you can measure an input signal whose peak value is ten times larger than the rated range value. Another area where crest factor is important is when you measure pulsed signals, because it can be challenging to accurately read the RMS voltage/current when a signal level that has an "on" period is followed by a period where no activity occurs.

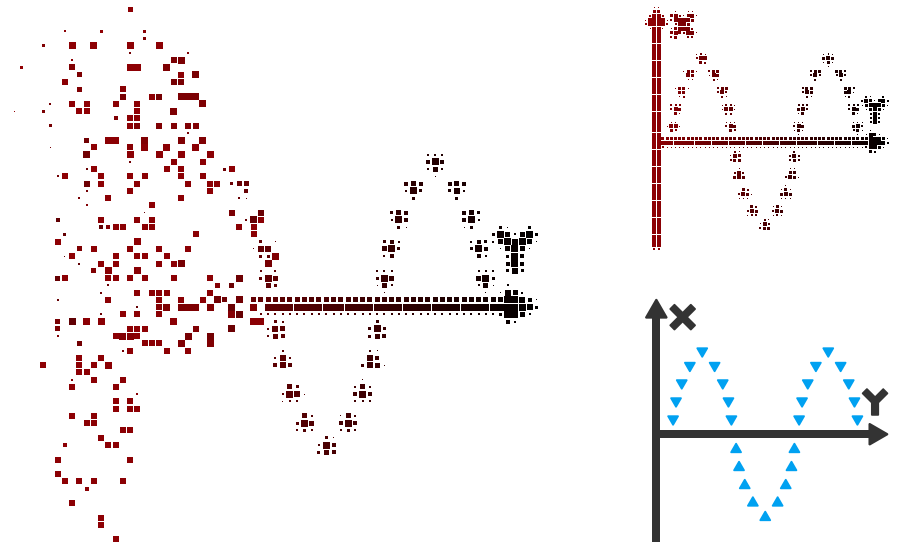



## CHAPTER 8

# Temperature Variations and Auto Calibration



# Temperature Variations and Auto Calibration

If you look at a DMM datasheet, you will normally find 90-day and 1-year specification columns. These columns display accuracy as  $\pm$  (percentage of reading + percentage of range), based on the your specific measurement.

Specification  $\pm$  (% of reading + % of range)

Range	24 hours $T_{ACAL} \pm 1^\circ\text{C}$	90 days $T_{ACAL} \pm 2^\circ\text{C}$	1 year $T_{ACAL} \pm 2^\circ\text{C}$	2 years $T_{ACAL} \pm 2^\circ\text{C}$	Non ACAL temperature coefficient/ $^\circ\text{C}$	With ACAL temperature coefficient/ $^\circ\text{C}$
DC voltage: 34465						
100 mV	0.0030 + 0.0030	0.0040 + 0.0035	0.0050 + 0.0035	0.0065 + 0.0035	0.0005 + 0.0005	0.0002 + 0.0005
1 V	0.0015 + 0.0004	0.0025 + 0.0004	0.0035 + 0.0004	0.0050 + 0.0004	0.0005 + 0.0001	0.0002 + 0.0001
10 V	0.0010 + 0.0003	0.0020 + 0.0004	0.0030 + 0.0004	0.0045 + 0.0004	0.0005 + 0.0001	0.0002 + 0.0001
100 V	0.0020 + 0.0006	0.0035 + 0.0006	0.0040 + 0.0006	0.0055 + 0.0006	0.0005 + 0.0001	0.0002 + 0.0001
1000 V	0.0020 + 0.0006	0.0035 + 0.0006	0.0040 + 0.0006	0.0055 + 0.0006	0.0005 + 0.0001	0.0002 + 0.0001

The table shows the datasheet for the new 34465A Truevolt DMM. The inclusion of 24 hour, 90 day, 1 year, and TC (temperature coefficient) columns are common for high-end DMMs.

If your measurement environment temperature—the ambient temperature where the DMM is operating— is not the same as the temperature of the DMM calibration, then you need to consider the TC error adjustment. An example is when a unit is calibrated at 22 °C but operating at 40 °C inside a test system. Such a rise in temperature is common in test sets inside of a system rack. We need to add in error due to TC specifications. Some high-end DMMs have an auto calibration (ACAL) feature, which greatly reduces temperature drift error. ACAL is the built-in ability of a DMM to compensate for temperature drift and internal errors. Auto calibration is also known as self calibration. If you are working in an environment where the ambient temperature is different than the recommended temperature range, it might be useful to look for a DMM with this ACAL feature.



## CHAPTER 9

# Triggering

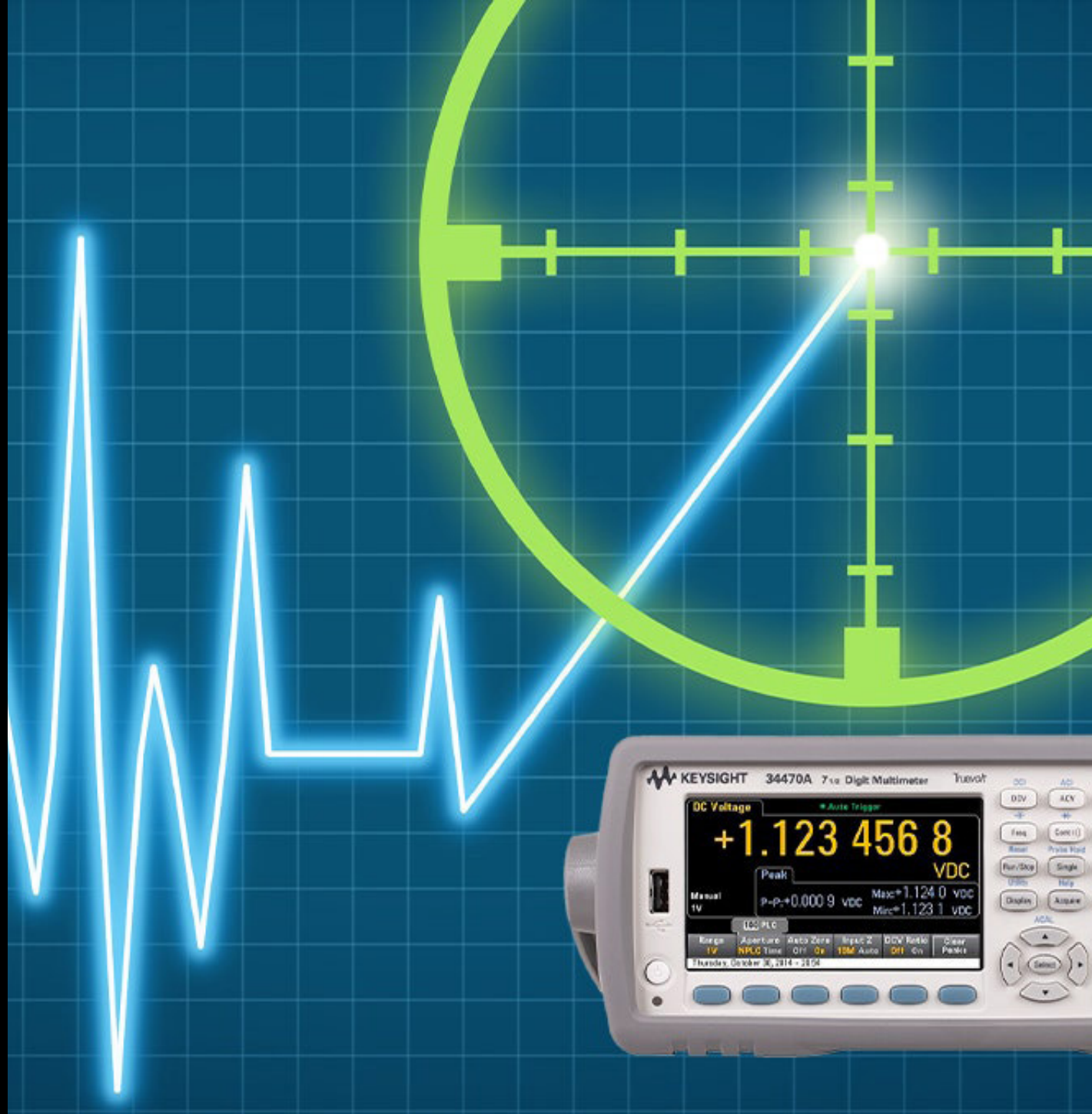

# Triggering

Triggering can improve throughput by acting as an alternative to inserting delays when you take measurements. Triggers allow you to start measurements, based on the detection of a trigger source. Trigger sources include continuous, external triggers such as BNC or BUS; level triggers, based on the signal crossing a certain threshold; or exhibiting triggers, which have a positive/negative slope. After trigger detection in most advanced DMMs, you can program a trigger delay and capture multiple sample periods. The results are digitized values returned over the BUS or displayed as a trend chart. Triggering is an important function to consider before purchasing a DMM, because these days many engineers do not need to perform continuous measurements. In the market today, many wireless battery-powered devices use pulsed signals. In addition, many designs today toggle between standby and action mode, so a DMM with a sophisticated triggering feature will save you setup and programming time.





## CHAPTER 10

# 4-Wire Measurements

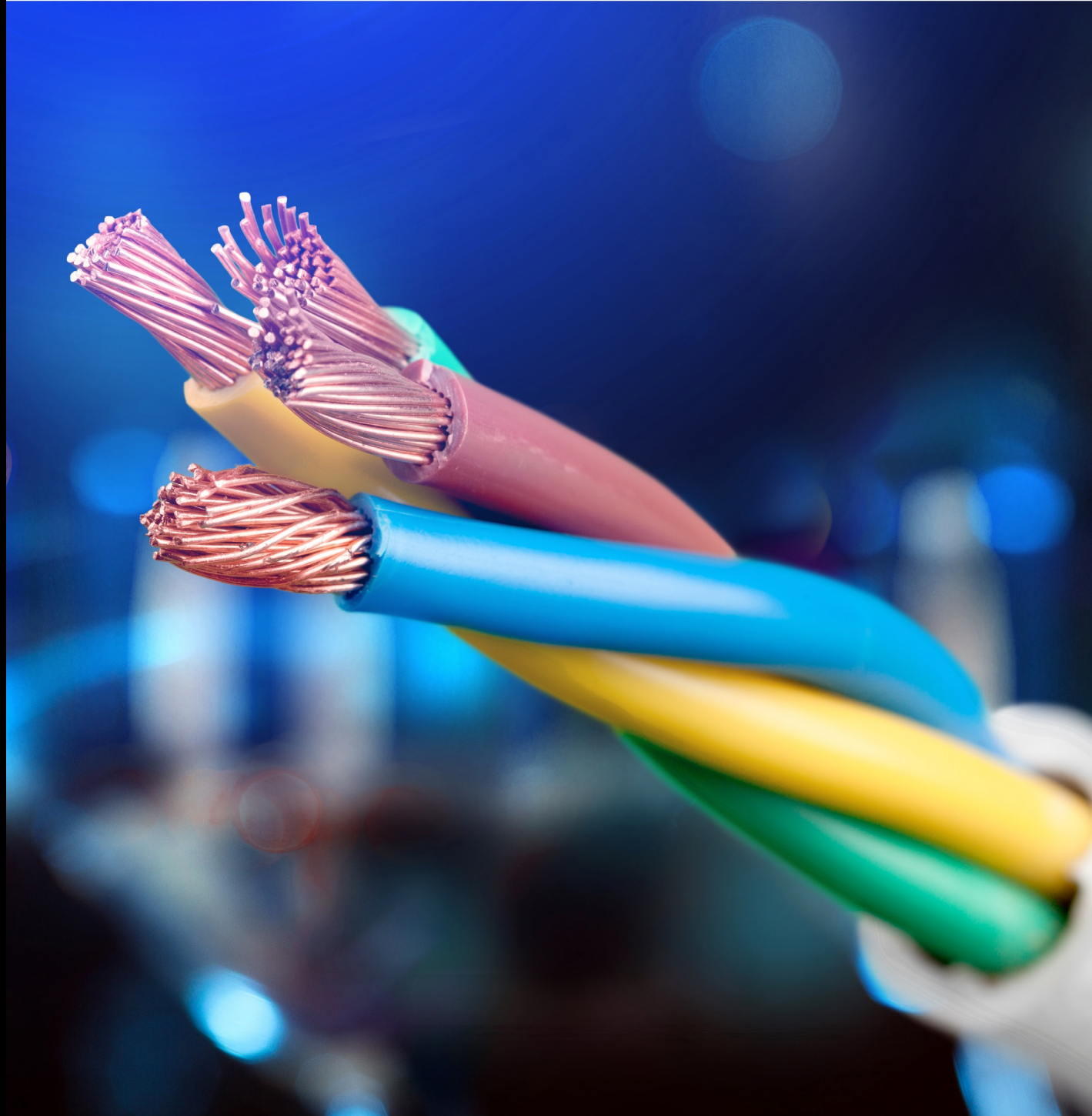

## 4-Wire Measurements

Improve measurement accuracy on your device under test by performing 4-wire measurements. There is resistance in the input leads of a DMM. This resistance causes a voltage drop and yield inaccuracies in measurements. The solution to this voltage-drop problem is 4-wire sensing. Perform your measurements right at the device under test hence bypassing the voltage drop introduced by the input leads. When you use 4-wire measurements, you ensure a greater level of accuracy compared to traditional 2-wire measurements. Most high-end bench top DMMs perform reliable, accurate 4-wire measurements. Most Handheld DDMs only perform 2-wire measurements. If you are working with applications requiring that extra level of accuracy, select a DMM that supports 4-wire measurements.

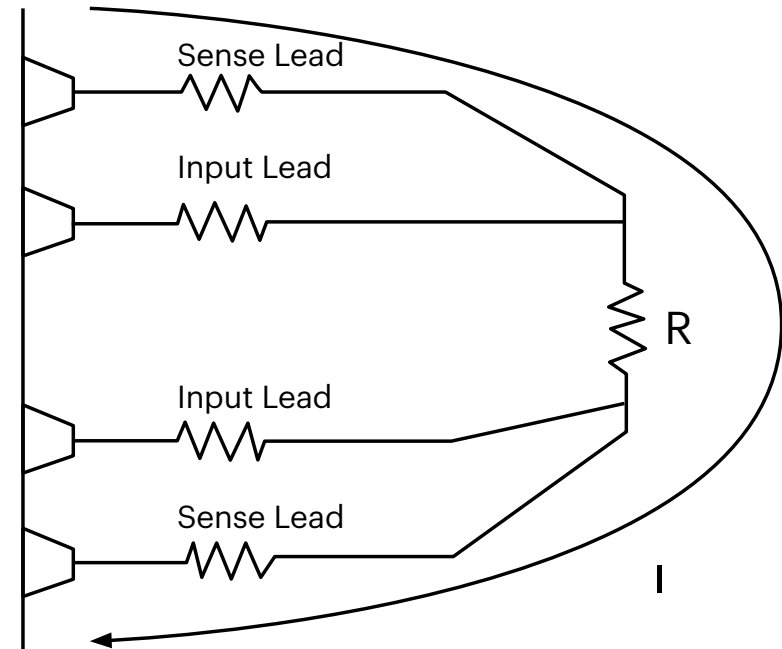

# Key Features

Display DMM results in ways you never have before

- Color, graphical display with built-in bar chart, histogram, trend (34461A only), math, and statistics
- Save and document your DMM's data from your PC, mobile device, or IO of choice
- Measure with unquestioned Truevolt confidence
- Digital AC, lowest measurement noise, ISO/IEC derived and compliant specifications
- 1000 V max voltage input, 3 A/10A (34461A) max current input
- Move to the next generation 34401A DMM with 100% assurance
- Industry's only 100% drop-in, SCPI compatible replacement for the Keysight 34401A DMM (34461A)





# Key Features

## Get more insight quickly

Truevolt DMM's graphical capabilities such as trend and histogram charts offer more insights quickly.

Both models also provide a data logging mode for easier trend analysis and a digitizing mode for capturing transients.

For more information on Keysight DMMs, visit:

<https://www.keysight.com/us/en/products/digital-multimeters-dmm.html>

For more information on PathWave BenchVue software, visit:

<https://www.keysight.com/us/en/products/software/pathwave-test-software/benchvue-software.html>

## Low-current measurements

The ability to measure very low current, 1  $\mu$ A range with pA resolution, allows you to make measurements on very low power devices.

## Maintaining calibration

Auto calibration allows you to compensate for temperature drift so you can maintain measurement accuracy throughout your workday.





Keysight enables innovators to push the boundaries of engineering by quickly solving design, emulation, and test challenges to create the best product experiences. Start your innovation journey at [www.keysight.com](http://www.keysight.com).