

# **User's and Service Guide**

## **Agilent Technologies 85024A High Frequency Probe**



**Agilent Technologies**

**Agilent Part Number 85024-90001**

**Printed in USA March 2000**

Supersedes August 1989

Copyright © 1989–2000 Agilent Technologies, Inc. All rights reserved.

---

## **Warranty**

This product is warranted against defects in material and workmanship for a period of one year from date of shipment. During the warranty period, Agilent Technologies will, at its option, either repair or replace products which prove to be defective.

For warranty service or repair, this product must be returned to a service facility designated by Agilent. Buyer shall prepay shipping charges to Agilent and Agilent shall pay shipping charges to return the product to Buyer. However, Buyer shall pay all shipping charges, duties, and taxes for products returned to Agilent from another country.

### **Limitation of Warranty**

The foregoing warranty shall not apply to defects resulting from improper or inadequate maintenance by Buyer, Buyer-supplied software or interfacing, unauthorized modification or misuse, operation outside of the environmental specifications for the product, or improper site preparation or maintenance.

NO OTHER WARRANTY IS EXPRESSED OR IMPLIED. AGILENT TECHNOLOGIES SPECIFICALLY DISCLAIMS THE IMPLIED WARRANTIES OF MERCHANTABILITY AND FITNESS FOR A PARTICULAR PURPOSE.

### **Exclusive Remedies**

THE REMEDIES PROVIDED HEREIN ARE BUYER'S SOLE AND EXCLUSIVE REMEDIES. AGILENT TECHNOLOGIES SHALL NOT BE LIABLE FOR ANY DIRECT, INDIRECT, SPECIAL, INCIDENTAL, OR CONSEQUENTIAL DAMAGES, WHETHER BASED ON CONTRACT, TORT, OR ANY OTHER LEGAL THEORY.

---

## **Assistance**

Product maintenance agreements and other customer assistance agreements are available for Agilent products.

For any assistance, contact the nearest Agilent sales or service office. Refer to [Table 7-1 on page 7-17](#) for a list of Agilent offices.

---

## How to Use This Guide

This guide uses the following conventions:

Front Panel Key

This represents a key physically located on the instrument.

**SOFTKEY**

This represents a “softkey”, a key whose label is determined by the instrument firmware.

---

**CAUTION** Caution denotes a hazard. It calls attention to a procedure that, if not correctly performed or adhered to, would result in damage to or destruction of the instrument. Do not proceed beyond a caution note until the indicated conditions are fully understood and met.

---

---

**WARNING** **Warning denotes a hazard. It calls attention to a procedure which, if not correctly performed or adhered to, could result in injury or loss of life. Do not proceed beyond a warning note until the indicated conditions are fully understood and met.**

---

---

**NOTE** All model numbers and part numbers published in this document are HP/Agilent numbers, unless otherwise specified.

---

---

# Contents

<b>1. General Information</b>	
Read This Before Using Your Probe	1-2
Input Voltage Tolerances	1-2
Anti-Static Precautions	1-3
Product Description	1-4
Specifications	1-5
General Characteristics	1-6
<b>2. Accessories</b>	
Probe Features and Accessories	2-2
Probe Adapter	2-4
Description	2-4
Operating Characteristics	2-4
Inspection	2-4
10:1 Divider	2-5
Operating Characteristics	2-5
Inspection	2-5
Replaceable Parts	2-6
Replacing the Probe Tip	2-6
<b>3. Installation</b>	
Initial Inspection	3-2
Certification	3-2
Preparation for Use	3-3
Power Requirements	3-3
Mating Connectors	3-4
Returning the Product for Service	3-5
<b>4. Operation</b>	
Operating Precautions	4-2
Operating Instructions	4-3
Grounding the Probe	4-3
Retracting and Extending the Protective Sleeve	4-3
Operator's Check	4-4
Operator's check Using a Network Analyzer	4-4
Required Equipment	4-4
Operator's Check Using a Spectrum Analyzer	4-5
Required Equipment	4-5
<b>5. Performance Tests</b>	
Recommended Test Equipment	5-3
Network Analyzer Operation	5-4
Presetting the Network Analyzer	5-4
Selecting a Transmission (or S21 Measurement)	5-4
Setting the Frequency Range	5-4
Setting CW Mode for Power Meter Measurements	5-4
Setting the Output Power Level	5-4
Performing a Response Calibration	5-4

---

# Contents

Median Gain and Frequency Response Flatness . . . . .	5-5
Description . . . . .	5-5
Procedure . . . . .	5-5
Gain Compression . . . . .	5-6
Description . . . . .	5-6
Procedure . . . . .	5-6
Calculating Equivalent Power . . . . .	5-7
Average Noise Level . . . . .	5-8
Description . . . . .	5-8
Procedure . . . . .	5-8
Test Record . . . . .	5-9
<b>6. Replaceable Parts</b>	
Introduction and Ordering Information . . . . .	6-2
Parts Lists . . . . .	6-3
<b>7. Service</b>	
Introduction . . . . .	7-2
Before You Troubleshoot . . . . .	7-2
Equipment Required for Troubleshooting . . . . .	7-2
Repair Strategy . . . . .	7-2
Probe Tip, Amplifier Microcircuit, and Regulator Assembly . . . . .	7-2
Main Cable and Plastic Sleeve Guide . . . . .	7-2
Theory of Operation . . . . .	7-3
ESD Protection at the Probe Tip . . . . .	7-3
Troubleshooting Procedures . . . . .	7-4
Mechanical Failure of the Protective Sleeve . . . . .	7-4
Electrical Failure of the Probe . . . . .	7-4
Visually Inspect the Probe Tip . . . . .	7-4
Power Supply Check . . . . .	7-4
Replacement Procedure . . . . .	7-8
Replacing the Probe Tip . . . . .	7-8
Replacing the Amplifier Microcircuit . . . . .	7-9
Removing the Plastic Regulator Housing Covers . . . . .	7-10
Reassembling the Covers . . . . .	7-10
Replacing the Type-N Output Connector . . . . .	7-11
Cable/Probe Wand Replacement . . . . .	7-12
Connector Inspection and Cleaning . . . . .	7-15
Inspecting the Connectors . . . . .	7-15
Visual Examination . . . . .	7-15
Cleaning Connectors . . . . .	7-15

---

# **1 General Information**

## Read This Before Using Your Probe

Your probe has been designed to provide years of uninterrupted service. Excellent performance at high frequencies requires the use of very small and delicate devices. Such components can be damaged by careless use.

### Input Voltage Tolerances

It is vital that the following specifications are not exceeded:

- Maximum safe DC input voltage (without 10:1 divider):  $\pm 50$  V
- Maximum safe DC input voltage through a 10:1 divider:  $\pm 200$  V
- Maximum safe RF voltage (without 10:1 divider): 1.5 V peak
- Maximum safe RF voltage through a 10:1 divider: 15 V peak

To minimize the potential for damage, always begin measurements with the 10:1 divider attached. Remove the 10:1 divider *only* when both of the following conditions are met:

- RF and DC levels are known to within the above tolerances.
- Higher sensitivity is required than is possible with the 10:1 divider attached.

When the probe is stored, attach the 10:1 divider and place the anti-static protection cap over the probe tip.

**Figure 1 Probe with 10:1 Divider and Anti-Static Protection Cap**

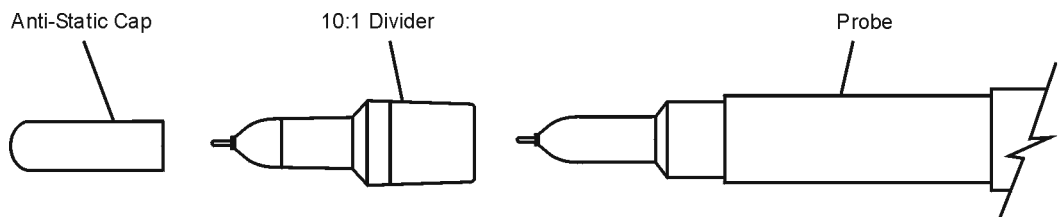

ao41a

## Anti-Static Precautions

Electrostatic discharge (ESD) is a serious problem; take consistent steps to eliminate it. This is important whenever using your probe.

- *Never touch the tip of the probe.* The probe microcircuit is susceptible to damage by static discharge.
- *Eliminate ESD on the body.* Wear a ground strap when using the probe.
- *Eliminate ESD on the work surface.* Use an anti-static bench mat. Never use the probe near a workbench that is covered by carpet.

*Do not introduce ESD into the device under test (DUT) while the probe is in use.* If an unprotected person touches part of the DUT, a static charge could damage the DUT as well as the probe.



## Product Description

Your high frequency probe is an active probe that provides low input capacitance, high input impedance, and wide bandwidth. The probe may be used with a variety of network analyzers, spectrum analyzers, frequency counters, and oscilloscopes.

The probe allows the testing of high frequency RF circuits. High input impedance is maintained by a Gallium Arsenide (GaAs) field effect transistor (FET) microcircuit.

When not in use, the probe tip is protected by a retractable grounded metal sleeve. This helps prevent electrostatic discharge damage to the probe, and protects the tip from breaking if the probe is dropped.

The probe tip may be inserted into the supplied probe adapter, adjusting the probe tip to a 50  $\Omega$  type-N male connector. The probe's output connector is a type-N male.

## Specifications

**Table 1-1 Product Performance**

Performance Parameter	Value	Code <sup>a, b</sup>
<b>Input Capacitance</b>	<0.7pF	N
<b>Input Resistance</b>	1 MΩ	N
<b>Bandwidth</b>	300 kHz to 3 GHz (usable to 100 kHz)	N
<b>Median Gain</b> (mid-point between max and min gains, 300 kHz to 1 GHz)	0 dB ±1.25 dB	S
<b>Frequency Response Flatness:<sup>c</sup></b>		
300 kHz to 1.0 GHz	±1.25 dB	S
1.0 GHz to 3.0 GHz	±2.5 dB	S
<b>Average Noise Level:</b>		
10 MHz Bandwidth	<1 mV rms RTI <sup>d</sup> (or -47 dBm)	N
3 GHz Bandwidth	<17 mV rms RTI <sup>d</sup> (or -23 dBm)	S
<b>Noise Figure:</b>		
<100 MHz	<50 dB	N
100 MHz to 3.0 GHz	<25 dB	N
<b>Gain Compression at 0.3 V Peak Input Voltage</b>	<1.0 dB	S
<b>Pulse Transition Time</b>	200 ps	N
<b>Distortion at 0.3 V Peak Input Voltage</b>	<-30 dBc	N
<b>Maximum Safe RF Input Voltage:</b>		
Without 10:1 Divider	1.5 V peak	S
With 10:1 Divider	15 V peak	S
<b>Maximum Safe DC Input Voltage:</b>		
Without 10:1 Divider	±50 V	N
With 10:1 Divider	±200 V	N

a. N = Nominal value: not warranted

S = Specification value: warranted

b. Specifications apply at 25 °C ±5 °C.

c. Relative to the Median Gain.

d. Referred to Input

---

## General Characteristics

Physical Characteristics	
Characteristics	Value
Probe Length <sup>a</sup>	130 cm (51 inches)
Net Weight	0.3 kg (0.66 pounds)
Shipping Weight	2.3 kg (5.1 pounds)

a. Overall length: includes wand, leads, and regulator assembly.

Environmental Characteristics		
Environmental Requirements	Operating	Storage
Temperature	0 °C to +55 °C	-40 °C to +70 °C
Altitude	Up to 4,600 meters (15,000 feet)	Up to 15,000 meters (50,000 feet)
Humidity	Protect this product from temperature extremes which can cause internal condensation.	

---

## **2 Accessories**

---

## Probe Features and Accessories

Figure 2-1 Probe Features

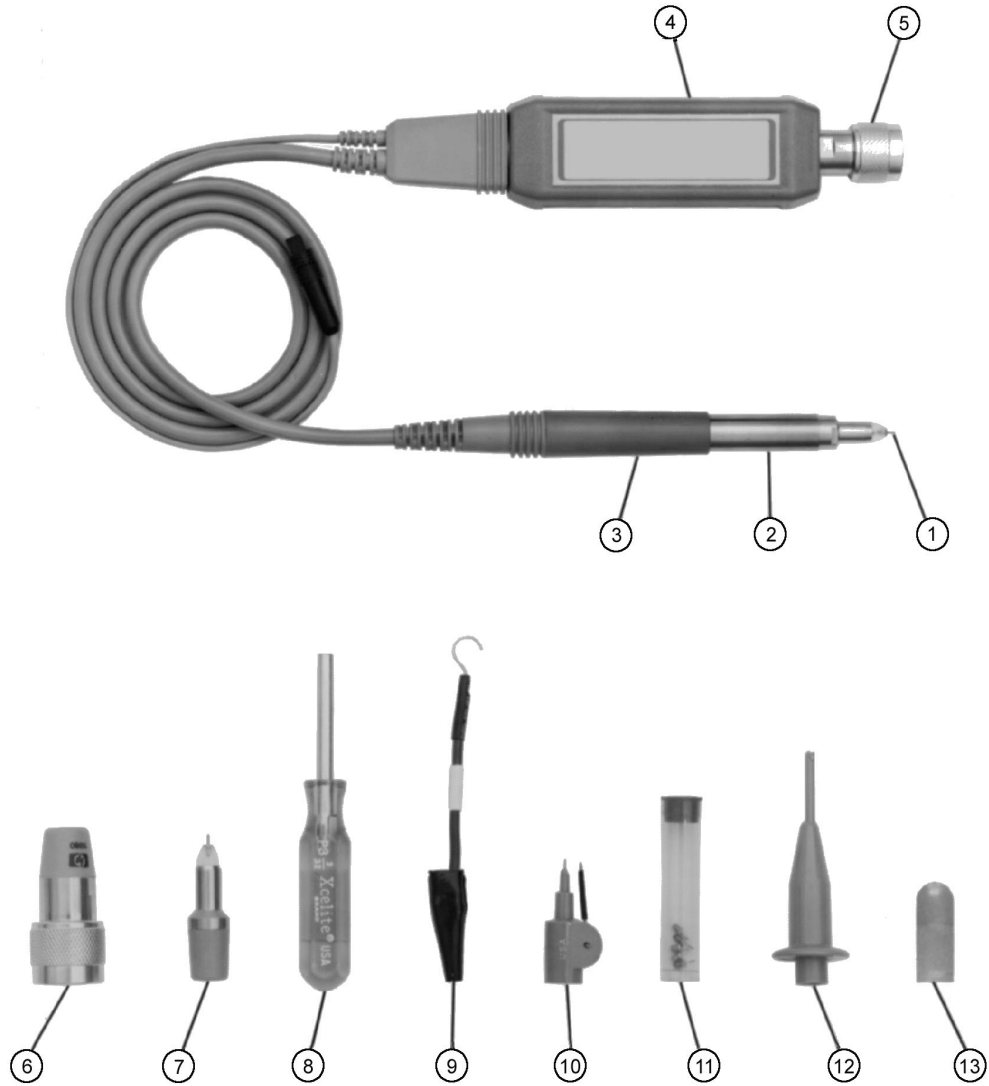

**Table 2-1 Probe Features**

Item	Description	Agilent Part Number
1	Probe Tip	85024-60015
2	Protective Sleeve	85024-60014
3	Probe Wand	85024-60014
4	Regulator Assembly	85024-60001
5	RF Output connector (type-N male)	85024-60013
6	Probe tip to type-N adapter	11880-60001
7	10:1 divider	11881-60001
8	Probe tip nut driver	8710-1806
9	Ground lead, flexible	01123-61302
10	Slip-on tip with grounding spike	5060-0549
11	Replacement tip (short) Replacement tip (long)	85024-60015 85024-60016
12	Hook tip adapter	10229A
13	Anti-static protection cap	08405-40003

**Table 2-2 Available Accessories**

Description	Agilent Part or Model Number
Type-N Connector Gage Kit	85054B
Adapter, type-N female to Precision 7 mm <sup>a</sup>	11524A
Adapter, type -N female to BNC male <sup>b</sup>	1250-1477
External DC Power Supply	11899A

- a. Used with the 85046A S-Parameter test set.
- b. Used with the 8590A spectrum analyzer.

## Probe Adapter

### Description

The probe adapter fits over the tip of the probe and converts the probe input to a 50  $\Omega$  type-N male connector. The adapter is only used when performance testing the probe.

### Operating Characteristics

Nominal Input Impedance	50 $\Omega$
Frequency Range	Same as the active probe (300 kHz to 3 GHz)

### Inspection

Periodically inspect the threads of the adapter for signs of wear and damage. Inspect the barrel of the probe receptacle, making sure it is clean and free of grit. Clean the adapter threads or receptacle with clean compressed air.

## 10:1 Divider

The 10:1 divider fits over the tip of the probe and provides the following changes to the probe's operating parameters:

- Increases (by a factor of 10) the input voltage at which 1 dB compression occurs.
- Decreases the input capacitance without changing input resistance, thereby decreasing capacitive loading.

Two or more dividers may be cascaded to provide higher divide ratios.

### Operating Characteristics

Divider Ratio	10:1
Input Capacitance	Typically <0.7 pF
Input Resistance	1 M $\Omega$
Input Voltage for 1 dB Compression	3.0 Volts Peak <sup>a</sup>
Maximum Safe DC Input Voltage	$\pm$ 200 Volts <sup>a</sup>
Maximum Safe RF Input Voltage	15 Volts Peak
Frequency Range	Same as the active probe (300 kHz to 3 GHz)

a. When used with the active probe.

### Inspection

Make sure the tip is not bent or discolored. Periodically inspect the barrel of the probe receptacle, making sure it is clean and free of grit. Clean the receptacle with clean compressed air.

When cascading 10:1 dividers, periodically inspect and clean the exterior of the metal sleeve.



## Replaceable Parts

If the tip is discolored, bent or broken, it must be replaced. Follow the procedure outlined in “Replacing the Probe Tip,” below.

**Figure 2-2 Exploded View of 10:1 Divider**

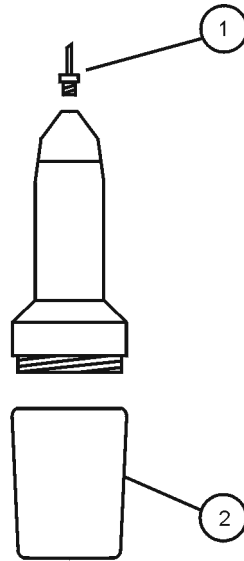

ao44a

Item	Description	Part Number
1	Short probe tip	85024-60015
	Long probe tip	85024-60016
2	Guide	11881-20007

### Replacing the Probe Tip

1. Remove the 10:1 divider from the probe.
2. Unscrew the damaged tip with a 3/32 nut driver supplied with the probe and discard the tip.
3. Screw on the new tip and lightly tighten it with a 3/32 inch nut driver.  
(Overtightening the tip can damage the nose assembly.)

---

## **3 Installation**

## Initial Inspection

If the shipping container or cushioning material is damaged, keep it until the contents of the shipment are checked for completeness, and the product is checked both mechanically and electrically. Procedures for checking the electrical performance are given in [Chapter 5](#), “Performance Tests.”

Notify the nearest Agilent Technologies office if the product does not pass performance tests, the shipping contents are incomplete, or if there is mechanical damage or defect. Notify the carrier if the shipping container is damaged or if the cushioning material shows signs of stress. Keep all shipping materials for the carrier’s inspection. Agilent Technologies will arrange for repair or replacement without waiting for a claim settlement.

---

## Certification

Agilent Technologies certifies that this product met its published specifications at the time of shipment from the factory. Agilent further certifies that its calibration measurements are traceable to the United States National Institute of Standards and Technology (NIST, formerly NBS), to the extent allowed by the institute’s calibration facility, and to the calibration facilities of other International Standards Organization members.

## Preparation for Use

**CAUTION** Electrostatic discharge (ESD), excessive input signals or mechanical shock can dramatically degrade the performance of the probe. Be sure to observe the following precautions.

- *Never touch the tip of the probe!*
- Always hold the probe by the retracted metal sleeve.
- Work at a workstation equipped with an anti-static mat.
- Extend the protective sleeve when not actually taking measurements.
- Wear an anti-static wrist strap and avoid introducing static electricity into the device under test (DUT) or test setup.
- Make sure the device under test (DUT) is at the same ground potential as the probe.

### Power Requirements

If using the probe with an instrument that does not supply probe power, use a separate power supply (such as the 11899A DC power supply) which provides two probe power connections. Make sure that any separate supply used meets the requirements shown in [Table 3-1](#). A male power connector is available for use with the probe (part number 5060-0467).

**Table 3-1 Probe Power Supply Requirements and Connector Pin-outs<sup>a</sup>**

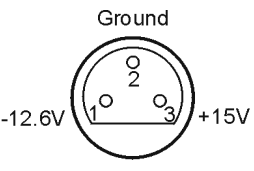
	Pin	Voltage	Current
	1	-12.6 V $\pm$ 20%	75 mA
	2	GND	
	3	+15 V $\pm$ 20%	150 mA

a. As seen looking into the probe's power connector.

## Mating Connectors

---

**CAUTION** Periodically inspect and, if necessary, clean the type-N output connector. Refer to [Chapter 7, “Connector Inspection and Cleaning,” on page 15](#). The probe adapter should be inspected at the same time, and cleaned if necessary.

---

## Returning the Product for Service

Contact Agilent Technologies before returning the probe for service. See [Table 7-1 on page 7-17](#). When shipping the probe to Agilent Technologies please include a blue service tag (found at the end of this manual) and a valid return mailing address. *Products cannot be returned to a post office box.* Provide the name and phone number of a contact person within your organization, the complete model and serial number of the product, and a complete description of the problem.

When shipping the probe for any reason, be sure to use the original (or comparable) packaging materials. Also mark the container **FRAGILE** to assure careful handling of the device.

When making inquiries, either by correspondence or by telephone, please refer to the probe by model and full serial number. Refer to [Table 7-1 on page 7-17](#) for a list of Agilent Technologies sales and service offices.

---

## **4 Operation**

## Operating Precautions

---

**CAUTION** Electrostatic discharge (ESD), excessive input signals or mechanical shock can dramatically degrade the performance of the probe. Be sure to observe the following precautions.

---

- *Never touch the tip of the probe!*
- Always hold the probe by the retracted metal sleeve.
- Work at a workstation equipped with an anti-static mat.
- Extend the protective sleeve when not actually taking measurements.
- Wear an anti-static wrist strap and avoid introducing static electricity into the device under test (DUT) or test setup.
- Make sure the device under test (DUT) is at the same ground potential as the probe.



---

## Operating Instructions

---

**CAUTION**     **Discharging the Probe Between Measurements**

Measuring a node having a DC voltage potential charges blocking capacitors inside of the probe. Ground the probe tip after measuring such nodes to discharge the probe capacitors. Failure to do this *can result in damage to sensitive circuits in the DUT*, especially if it is an active device.

---

### Grounding the Probe

Proper grounding is important when making measurements with any probe. The probe is supplied with two grounding devices: an alligator-type ground clip and a slip-on type ground tip. Use the shortest ground path possible. Proper grounding becomes more important as frequency increases. For optimum measurements in a factory environment, design your circuits with ground-plane feedthroughs next to every test point.

### Retracting and Extending the Protective Sleeve

Hold the probe wand in one hand, pointing the tip away from yourself. Grasp the probe sleeve in the other hand and turn about 1/4 turn counter-clockwise. Now, pull the sleeve toward you while *slowly* turning it counter-clockwise. The sleeve will now retract quickly with little counter-clockwise rotation. Reverse this procedure to extend the sleeve.

## Operator's Check

The operator's check is designed to be a simple functional test for the probe. If the probe fails the operator's check, or if you need to verify that the probe meets its warranted specifications, you will need to do the performance tests as described in [Chapter 5](#), "Performance Tests."

The operator's check can be performed with either a network analyzer or a spectrum analyzer. Use one of the following two procedures to perform the operator's check.

### Operator's check Using a Network Analyzer

#### Required Equipment

Item	Part Number
Network Analyzer	Any compatible with type-N connectors
Type-N Cable	50Ω, male connectors
Probe Adapter	11880-60001

#### Procedure

---

**NOTE** If you are not familiar with network analyzer operation, refer to ["Network Analyzer Operation"](#) on page 5-4 for basic information about performing the analyzer operations used in this procedure.

---

1. Preset the analyzer using the **PRESET** hardkey.
2. Configure the analyzer to measure transmission.
3. Set the output power level of the analyzer to 0 dBm.
4. Set the frequency sweep range on the analyzer from 300 kHz to 3 GHz.
5. Connect a type-N cable (a through cable) between the output and the input ports on the analyzer.
6. Perform a response calibration on the analyzer. The trace on the analyzer should now be flat at 0 dB.
7. Remove the through cable. Connect the probe adapter to the output port of the analyzer. Connect the output of the probe to the input port of the analyzer. Connect the probe power cable to a power source.
8. Plug the probe tip into the adapter.
9. The trace of the analyzer should be within  $\pm 5$  dB of 0 dB.

## Operator's Check Using a Spectrum Analyzer

### Required Equipment

Item	Part Number
Spectrum Analyzer	Any Compatible
Adapters	As Necessary
Probe Adapters	11880-60001

### Procedure

1. Connect the spectrum analyzer's calibration output directly to its RF input. Turn on the spectrum analyzer.
2. Set the spectrum analyzer center frequency to the frequency of the calibration output.
3. Set the frequency span to 10 MHz and activate a marker.
4. Place the marker on the peak of the displayed signal and note the value in dBm.
5. Connect the probe adapter to the calibration output.
6. Connect the probe output to the RF input on the analyzer.
7. Connect the probe power cable to a power source.
8. Plug the probe tip into the probe adaptor.
9. Place the marker on the peak of the displayed signal and compare the signal level in dBm to that measured in step 4. The probe should not cause more than 5 dBm of signal loss.

---

## **5 Performance Tests**

The procedures in this chapter test the probe to ensure that it meets the warranted specifications listed in [Table 1-1 on page 1-5](#). The “[Test Record](#)” on [page 5-9](#) provides space to record the test results. Each of the tests can be performed without access to the interior of the probe. Follow the procedures, record data on the “[Test Record](#)” on [page 5-9](#), perform the calculations, and determine pass or fail for each test item. All tests must pass for the performance test to be verified.

---

**NOTE**        The performance tests in this chapter cover the specifications for a standard 85024A probe. If the serial number label indicates an option, contact Agilent Technologies for applicable specifications. Refer to [Table 7-1 on page 7-17](#) for a list of Agilent Technologies sales and service offices.

---

## Recommended Test Equipment

Table 5-1 lists the equipment that is recommended for use in performance testing of the probe. Other equipment may be substituted if its specifications meet or exceed the specifications listed in the “Critical Specifications” column.

**Table 5-1 Recommended Test Equipment**

Type	Critical Specifications	Recommended Model or Part Number
Vector Network Analyzer	300 kHz to 3 GHz	8714ET/ES, 8753ET/ES, 8753E <sup>a</sup>
Power Meter		437B/438A, or E4418A/E4419A
Power Sensor	300 kHz to 3 GHz –30 dBm to +5 dBm	8482A
Type-N Cable, male-to-male	50Ω	8120-8862 or equivalent
Probe Adapter	Supplied with probe	11880-60001
Attenuator, type-N, 50 Ω	any value 10 to 20 dB nominal	8491A/B/C Option 20, Option 10, or equivalent
Type-N Adapter, female-to-female		1250-0777 or equivalent

- a. Many models of network analyzers can be used for these performance tests. The network analyzer must cover the frequency range 300 kHz to 3 GHz, and be capable of power output in the range of –3 to +5 dBm.

## Network Analyzer Operation

This section provides some general information for performing basic network analyzer operations. For more specific operating information, refer to your analyzers user's guide.

### Presetting the Network Analyzer

All analyzers have a **PRESET** hardkey for this function.

### Selecting a Transmission (or S21 Measurement)

<i>871x family</i>	Press <b>MEAS 1</b> , then <b>Transmission</b> or <b>Fwd Trans S21</b> .
<i>8753 family</i>	Press <b>Chan 1</b> or <b>CH 1</b> , then <b>Meas</b> followed by <b>Transmission</b> or <b>TRANS:FWD</b> .

### Setting the Frequency Range

<i>871x family</i>	Start and stop frequencies are accessed via <b>FREQ</b> .
<i>8753 family</i>	Start and stop frequencies are accessed via <b>Start</b> and <b>Stop</b> .

### Setting CW Mode for Power Meter Measurements

<i>871x family</i>	Press <b>FREQ</b> <b>CW</b> , then <b>MENU</b> and set the Trigger mode to <b>Hold</b> . To return to normal operation, set the trigger mode to <b>Continuous</b> and define start and stop frequencies.
<i>8753 family</i>	Press <b>Menu</b> or <b>Sweep Setup</b> to access both the sweep and trigger functions. The <b>CW FREQ</b> softkey activates CW mode, press <b>TRIGGER MENU</b> then <b>HOLD</b> . To return to normal operation, change the trigger mode to <b>CONTINUOUS</b> , <b>Menu</b> or <b>Sweep Setup</b> , then <b>SWEEP TYPE MENU</b> followed by <b>LIN FREQ</b> .

### Setting the Output Power Level

<i>871x family</i>	Press <b>POWER</b> .
<i>8753 family</i>	Press <b>Menu</b> or <b>Sweep Setup</b> to access <b>Power</b> .

### Performing a Response Calibration

<i>871xC and 871xET</i>	Press <b>CAL</b> , then <b>Response</b> . Press <b>Measure Standard</b> when the through cable is connected.
<i>871xES</i>	Press <b>CAL</b> , <b>User Response</b> , then <b>Response</b> . Press <b>Measure Standard</b> when the through cable is connected.
<i>8753 family</i>	Press <b>Cal</b> , <b>CALIBRATE MENU</b> , then <b>Response</b> . Press <b>THRU</b> when the through cable is connected.

## Median Gain and Frequency Response Flatness

Specifications (at 25 °C ±5 °C)	
Median Gain over 300 kHz to 1 GHz	0 dB ±1.25 dB
Frequency Response Flatness (Relative to Median Gain)	
300 kHz to 1 GHz	±1.25 dB
1 GHz to 3 GHz	±2.5 dB

### Description

This test procedure performs a response calibration on the analyzer and then measures the gain of the probe over frequency. Maximum and minimum gains in two different frequency bands are used to determine the probe performance.

### Procedure

1. Preset the analyzer using the **PRESET** hardkey.
2. Set the frequency sweep range for 300 kHz to 3 GHz.
3. Set the analyzer for a transmission (S21) measurement.
4. Connect a type-N cable between the output port and input port on the analyzer.
5. Perform a response calibration on the analyzer. The trace on the analyzer should now be a flat line at 0 dB.
6. Disconnect the cable from the output port of the analyzer. Connect the type-N barrel to the free end of the cable.
7. Connect the probe adapter to the output port of the analyzer. Connect the probe between the probe adapter and the type-N barrel. Plug the probe power cable into the front panel of the analyzer.
8. Read the following four values from the trace on the analyzer and enter the values on the **“Test Record”** on page 5-9. Use the network analyzer marker functions as needed.

Maximum gain in dB over the frequency range of 300 kHz to 1 GHz (A).

Minimum gain in dB over the frequency range of 300 kHz to 1 GHz (B).

Maximum gain in dB over the frequency range of 1 GHz to 3 GHz (C).

Minimum gain in dB over the frequency range of 1 GHz to 3 GHz (D).

Perform the calculations indicated on the test record to determine the results of the test.



## Gain Compression

Specifications (at 25 °C ±5 °C)	<1.0 dB at 0.3 V Peak
In a 50 Ω system	0.3 V Peak = -0.458 dBm

### Description

This test identifies the frequency of greatest compression at a signal level of 0.3 V peak (-0.458 dBm). It then uses a power meter to precisely measure the compression at that frequency.

### Procedure

1. Select an attenuator to use: its nominal value must be in the 10 to 20 dB range.
2. Plug the power sensor into the power meter and turn on the power meter. Allow them to warm up for 3 minutes.
3. Calibrate and zero the power meter and the power sensor.
4. Preset the analyzer using the **PRESET** hardkey.
5. Set up the analyzer to measure transmission (S21) over the 300 kHz to 3 GHz range.
6. Set the power level on the analyzer to 0 dBm.
7. Connect the probe adapter to the output of the analyzer.
8. Connect the output of the probe to the input port of the analyzer. Plug the probe tip into the adapter. Connect the probe power cable to a power source.
9. Perform a response calibration on the analyzer using the probe as the “through cable.” The trace on the analyzer should now be a flat line at 0 dB.
10. Insert the attenuator between the output port of the analyzer and the probe adapter. Reconnect the probe to the probe adapter.
11. Determine the frequency of peak gain on the trace of the analyzer. Record the frequency on the test record.
12. Set the analyzer to CW mode for power meter measurements. Set the CW frequency to the value determined in the previous step.
13. Remove the attenuator from the output port of the analyzer.
14. Connect the power sensor to the output port of the analyzer. Adjust the analyzer power output level to produce a reading of 0.0 dBm on the power meter. (Note: 0.0 dBm is used to allow for possible inaccuracy of power meters).
15. Disconnect the power sensor from the output port of the analyzer. Connect the attenuator to the output port of the analyzer.

16. Connect the probe, the probe adapter, and a barrel between the attenuator and the power sensor. The signal from the analyzer should now go through the attenuator and then the probe before reaching the power sensor. Record the power reading on the “Test Record” on page 5-9 (item F).
17. Remove the attenuator pad, connect the probe adapter to the output port of the analyzer. Connect the attenuator pad between the probe and the power sensor. The signal from the analyzer should now go through the probe and then the pad before reaching the power sensor. Record the power reading on the “Test Record” on page 5-9 (item G).
18. Perform the calculation indicated on the test record to determine the result of the test.

### Calculating Equivalent Power

The probe is usually used as a high impedance device. The compression specification is given as a voltage (instead of power) because of the wide range of devices with which the probe may be used. For testing the probe, the probe adapter is used to make the probe input 50 Ω. Using this known impedance, an equivalent power can be calculated.

To find the power level equivalent to the 0.3 peak voltage, perform the following mathematical steps:

Steps	Formula	Example
1. Convert the peak voltage into RMS.	$\frac{V_{pk}}{1.4142135}$	$\frac{0.3V}{1.4142135} = 0.212132V_{RMS}$
2. Convert the RMS voltage to a raw power.	$\frac{V^2}{R}$	$\frac{(0.212132)^2}{50\Omega} = 0.0009w$
3. Convert the raw power to a power which is relative to 1 mW.	divide by 0.001w	$\frac{0.009w}{0.001w} = 0.9$
4. Convert to dBm.	10(LOGx)	10(LOG 0.9) = -0.458 dBm*
* Therefore, as shown in the example, the equivalent power to 0.3 V peak in a 50 Ω system is -0.458 dBm.		

## Average Noise Level

**Specifications** (at 25 °C ±5 °C): <17 mV RTI (or -23 dBm at probe output)

### Description

This test procedure uses a power meter to measure the power level of the probe output when the probe tip is connected through 50 ohms to ground.

### Procedure

1. Connect the power sensor to the power meter and allow the power meter to warm up for five minutes.
2. Calibrate and zero the power meter.
3. Enable averaging on the power meter.
4. Connect the power cable on the RF probe to a power source, allow the probe to warm up for at least three minutes.
5. Connect the probe tip adapter to the tip of the probe. (This effectively grounds the probe tip).
6. Connect the RF probe to the power sensor using a type-N barrel.
7. Read the power meter. If the reading is unstable, visually determine the approximate peak value over a period of about twenty seconds. Record that value on the test record.

## Test Record

85024A High Frequency Probe Test Record					
Serial Number:			Date:		
Tested By:			Temperature:		
Median Gain and Frequency Response Flatness		Results <sup>a</sup>	Limits		Pass/ Fail
			Max	Min	
A	Maximum gain over 300 kHz to 1 GHz	dB	N/A	N/A	N/A
B	Minimum gain over 300 kHz to 1 GHz	dB	N/A	N/A	N/A
C	Maximum gain over 1 GHz to 3 GHz	dB	N/A	N/A	N/A
D	Minimum gain over 1 GHz to 3 GHz	dB	N/A	N/A	N/A
E	Median Gain (A+B)/2 =	dB	1.25	-1.25	
	LF maximum gain A - E =	dB	1.25	0	
	LF minimum gain B - E =	dB	0	-1.25	
	HF maximum gain C - E =	dB	2.5	-2.5	
	HF minimum gain D - E =	dB	2.5	-2.5	
Gain Compression					
	Frequency at maximum gain		N/A	N/A	N/A
F	Pad before probe	dBm	N/A	N/A	N/A
G	Pad after probe	dBm	N/A	N/A	N/A
	Compression, F - G =	dBm	+1.0	N/A	
Average Noise Level					
	Power level	dBm	-23	N/A	

a. Reminder: Include polarity (+/-) in all recorded values and calculations.

---

## **6 Replaceable Parts**

## Introduction and Ordering Information

The replaceable parts lists are organized as follows:

- [Table 6-2](#) contains components and assemblies of the high frequency probe given in alphabetic/numerical order by reference designation.
- [Table 6-3](#) contains components of the A1 regulator assembly listed in alphabetic/numerical order by reference designation.

---

**NOTE**        The total quantity for each part is given only once, at the first appearance of the part in the list.

---

To order a part listed in the replaceable parts list, indicate the Agilent part number and the quantity desired. Address the order to the nearest Agilent Technologies office.

To order a part that is not listed in the replaceable parts list, include the probe model and serial number, the description and function of the part and the quantity desired. Address the order to the nearest Agilent Technologies office. See [page 7-17](#) for a list of Agilent Technologies sales and service offices.

## Parts Lists

**Table 6-1 Miscellaneous Replacement Parts**

Part Number	Qty	Description
08405-40003	1	Anti-Static Protection Cap <sup>a</sup>
1401-0214	1	Protective End Cap for type-N Connector
85024-90001	1	Operating and Service manual
85024-80001	2	Side Label
85024-80003	1	Product Case
85024-80004	1	Bottom Foam of the Product Case
5180-8448	1	Top Foam of the Product Case
01123-61302	1	Ground Lead, Flexible <sup>a</sup>
5060-0549	1	Ground Tip, Slip-On with Grounding Spike <sup>a</sup>
10229A	1	Hook Tip Adapter <sup>a</sup>
8710-1806	1	3/32 inch Probe Tip Nut Driver <sup>a</sup>
11880-60001	1	Type-N Probe Adapter <sup>a</sup>
11881-60001	1	10:1 Divider <sup>a</sup>
<b>Service Tool</b>		
85024-20041		Spanner / Wrench (see <a href="#">Figure 7-10</a> )
<b>General Accessories</b>		
1250-1477		Adapter, type-N female to BNC male <sup>b</sup>

a. Shown in [Figure 2-1](#).

b. For use with the 8590A Spectrum Analyzer.

**Table 6-2 Replaceable Parts**

Item <sup>a</sup>	Part Number	Qty	Description
1	85024-60013		Connector Replacement Kit
2	85024-20024	1	RF Bead
3	85024-20016	1	Transition-Nut
4	85024-20017	1	Transition-REG
5	0515-0912	2	Screw-Machined M3 x 0.5 8 mm-LG Pan Head
6	85024-20028	1	Frame Casting
7	85024-20025	1	Nut, Strain Relief
8	85024-60014		Cable/Probe Wand Kit (pre-assembled)
9	0515-0950	2	Screw-Machined M2 8 mm-LG Pan Head
10	0515-0976	2	Screw-Machined M2 6 mm-LG Pan Head
11	85024-20015	1	Probe Nut
12	85024-60015	1	Short Power Tip (also used on 10:1 Divider)
	85024-60016	1	Long Power Tip
13	85024-60011	1	Nose Assembly
14	85024-40007	1	Conductive Washer
15	85024-60005	1	Amplifier Microcircuit
16	85024-20037	1	Clip Spring for Elastic Conductive Strip
17	85024-20035	1	Elastic Conductive Strip
18	85024-40001	1	Regulator assembly Plastic Covers (set)
19	85024-00002	1	Housing Reinforcement
20	5040-0494	1	Connector Sleeve (power)
21	5060-0466	1	Connector Body (power)

a. See [Figure 6-1, "Replaceable Parts Identification."](#)



**Figure 6-1 Replaceable Parts Identification**

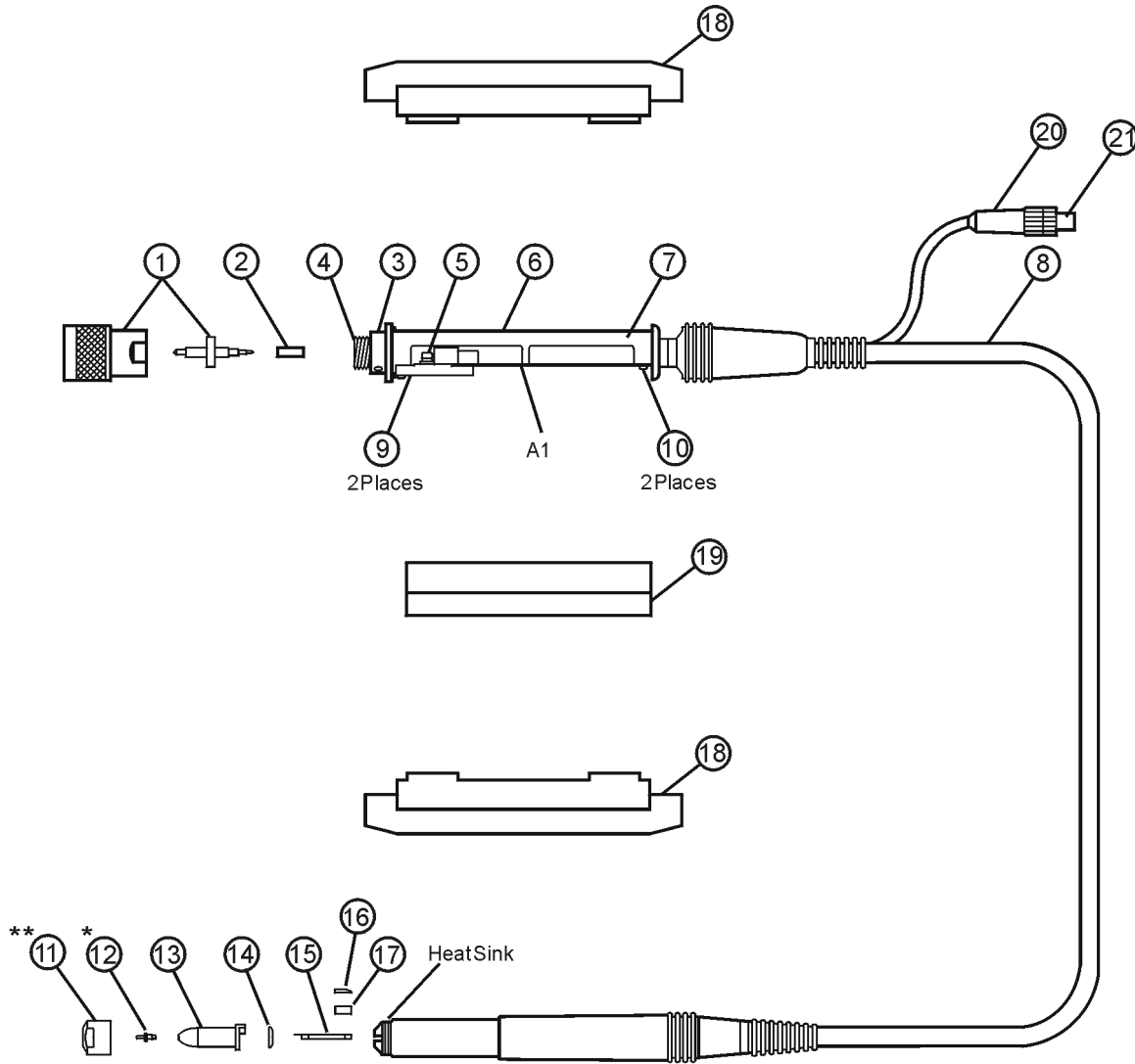

ao416a

---

**\* CAUTION** Failure to remove the nose assembly prior to replacing the tip will result in damage to the conductive elastomer on the tip assembly.

---

---

**\*\* NOTE** Item 11 is a nut which slides over items 12 through 17 and screws onto the end of the heat sink.

---

**Table 6-3 A1 Regulator Assembly Replaceable Parts**

Reference Designation <sup>a</sup>	Part Number	Qty	Description
A1	85024-60014	1	Regulator Assembly
A1C1	0160-3879	2	Capacitor-FXD 0.01 $\mu$ F $\pm$ 20% 100VDC CER
A1C2	0180-3771	6	Capacitor-FXD 1 $\mu$ F $\pm$ 10% 35VDC Ta
A1C3	0180-3771		Capacitor-FXD 1 $\mu$ F $\pm$ 10% 35VDC Ta
A1C4	0180-3771		Capacitor-FXD 1 $\mu$ F $\pm$ 10% 35VDC Ta
A1C5	0160-3879		Capacitor-FXD 0.01 $\mu$ F $\pm$ 20% 100VDC CER
A1C6	0180-3771		Capacitor-FXD 1 $\mu$ F $\pm$ 10% 35VDC Ta
A1C7	0180-3771		Capacitor-FXD 1 $\mu$ F $\pm$ 10% 35VDC Ta
A1C8	0180-3771		Capacitor-FXD 1 $\mu$ F $\pm$ 10% 35VDC Ta
A1MP1			Not Assigned
A1MP2	1200-0172	1	Insulator-Transistor DAP-GL
A1MP3	85024-20033	1	Heatsink-REG
A1MP4	0340-0949	2	Insulator-Transistor Thermal Conductor
A1MP5	3050-1021	2	Washer, Shoulder No. 4 0.116-in.-ID 0.215-in.-OD
A1MP6	0515-0912	2	Screw-Machine M3 x 0.5 8 mm-LG Pan Head
A1MP7	0361-0010	2	Rivet-AL 0.123D x 0.219L
A1Q1	1854-0477	1	Transistor NPN 2N2222A SI TO-18 PD = 500 MW
A1R1	0698-3391	1	Resistor 21.5 1% 0.5 W FTC = 0 $\pm$ 100
A1R2	0757-0442	1	Resistor 10k 1% 0.125 W FTC = 0 $\pm$ 100
A1R3	0698-0083	1	Resistor 1.96k 1% 0.125 W FTC = 0 $\pm$ 100
A1R4	0757-0416	1	Resistor 511 1% 0.125 W FTC = 0 $\pm$ 100
A1R5	0698-3437	2	Resistor 133 1% 0.125 W FTC = 0 $\pm$ 100
A1R6	0757-0198	1	Resistor 100 1% 0.5 W FTC = 0 $\pm$ 100
A1R7	0698-3444	1	Resistor 316 1% 0.125 W FTC = 0 $\pm$ 100
A1R8	0698-3437		Resistor 133 1% 0.125 W FTC = 0 $\pm$ 100
A1U1	1826-0393	1	IC V Regulator-Adjust-Pos 1.2 / 37 V TO-220 pkg.
A1U2	1826-0527	1	IC 337 V Regulator-Adjust-Neg TO-220 pkg.

a. If necessary, refer to "A1 Regulator Assembly Component Locations Diagram" on page 7-7.

---

## **7 Service**

## Introduction

This chapter contains troubleshooting and repair information. Heed caution signs to avoid damaging the probe. You may wish to read the [“Theory of Operation” on page 7-3](#), with its associated diagrams as an aid to troubleshooting.

### Before You Troubleshoot

Troubleshooting the probe begins with performing the [“Operator’s Check” on page 4-4](#), and the [Chapter 5 , “Performance Tests.”](#) If the probe does not pass the performance tests, refer to the [“Troubleshooting Procedures” on page 7-4](#).

### Equipment Required for Troubleshooting

Troubleshooting procedures require the use of a digital multimeter.

### Repair Strategy

#### Probe Tip, Amplifier Microcircuit, and Regulator Assembly

The probe tip and amplifier microcircuit are easily replaced. The regulator assembly (A1) repair can be performed at either assembly or component level. Module exchange programs are not available for this product.

#### Main Cable and Plastic Sleeve Guide

The main cable includes the probe wand, the main cable and the smaller power supply cable. If the cable is damaged, both the cable and the probe wand assembly must be replaced as a single unit. In this case, take the following parts off of the old probe for use on the replacement probe:

- The nose assembly
- Nut
- Amplifier microcircuit

These items are shown in [Figure 7-6 on page 7-8](#) and [Figure 7-7 on page 7-9](#).

A kit is available that provides a preassembled main cable and probe wand. The wand does not come with the amplifier microcircuit, nose-assembly, or tip, because these may be easily removed from your old probe wand. Refer to [Table 6-2 on page 6-4](#), for the part number of the kit.

## Theory of Operation

The probe uses a Gallium Arsenide FET integrated circuit amplifier which provides unity gain. This amplifier microcircuit requires +6 V and -4 Vdc to operate. These voltages are provided by the regulator assembly.

The regulator assembly converts the +15 volt and -12.6 volt supplies from the host instrument with two voltage regulators. The regulator supplies the +6 and -4 voltages to the amplifier microcircuit.

The most common failures in the probe will all result in loss of signal through the probe, and will show up if the operator's check is performed. The most common failures are expected to be:

1. Destruction of the amplifier microcircuit due to static electricity (proper anti-static precautions not taken).
2. Probe power tip damage (caused by the operator dropping the probe with the sleeve retracted).
3. Possible regulator failure.

## ESD Protection at the Probe Tip

The FET integrated circuit amplifier is located at the tip of the probe. The FET input of the amplifier is protected by a bidirectional voltage limiter as shown in [Figure 7-1](#).

**Figure 7-1 Probe Tip Input Circuit**

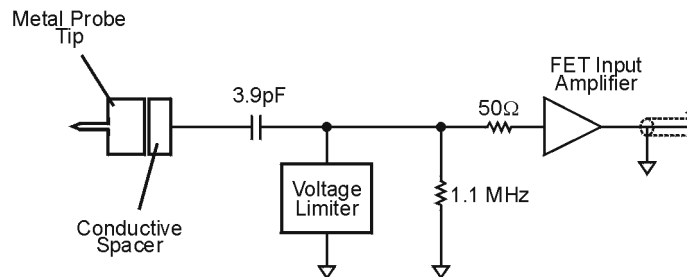

ao419a

The voltage limiter element has a negligible effect on circuit operation for input voltages within specification. The voltage limiter is a non-linear element: it begins to conduct current at about 2.5 volts. It effectively limits voltages at the amplifier input to less than  $\pm 4$  volts. This prevents amplifier damage from low levels of ESD.

Even with the protection provided by the voltage limiter element, the probe is still sensitive to ESD. High levels of ESD can cause permanent damage to the voltage limiter element itself. Careful ESD precautions must be observed when using the probe.

## Troubleshooting Procedures

---

**CAUTION** The probe contains an input GaAs amplifier microcircuit that is highly sensitive to electrostatic discharge (ESD). *When repairing this probe, you must use an anti-static wrist strap, and work at a station equipped with an anti-static surface!* Before you take a measurement with a digital multimeter, discharge the leads by touching them to ground.

---

### Mechanical Failure of the Protective Sleeve

The probe wand/cable must be replaced if the protective sleeve fails to slide and lock properly.

### Electrical Failure of the Probe

#### Visually Inspect the Probe Tip

Inspect the probe tip for damage. If it is bent or broken, replace it by referring to [“Replacing the Probe Tip” on page 7-8](#). Perform the [“Operator’s Check” on page 4-4](#). If the problem persists, perform the following procedure.

#### Power Supply Check

Refer to the probe schematic in [Figure 7-2 on page 7-5](#) when performing the following procedure.

1. Check the probe power output from the supplying instrument or power supply. The output pins and voltages are shown in [Figure 7-4 on page 7-6](#). Check continuity of the ground pin to chassis ground; it should be less than 1Ω.
  - If the supplies are within the tolerances given in [Table 3-1 on page 3-3](#), continue to step 2.
  - If the voltage is not present at the supplying device, or the ground pin is open, troubleshoot as required. Suspect a broken wire going to the probe power jack.
2. Follow the procedure in [“Replacing the Amplifier Microcircuit” on page 7-9](#), to remove the probe’s nose assembly, amplifier microcircuit, elastic conductive strip, and spring clip. These items are illustrated in [Figure 7-3 on page 7-5](#).

**Figure 7-2 A1 Regulator Schematic Diagram and Overall Block Diagram**

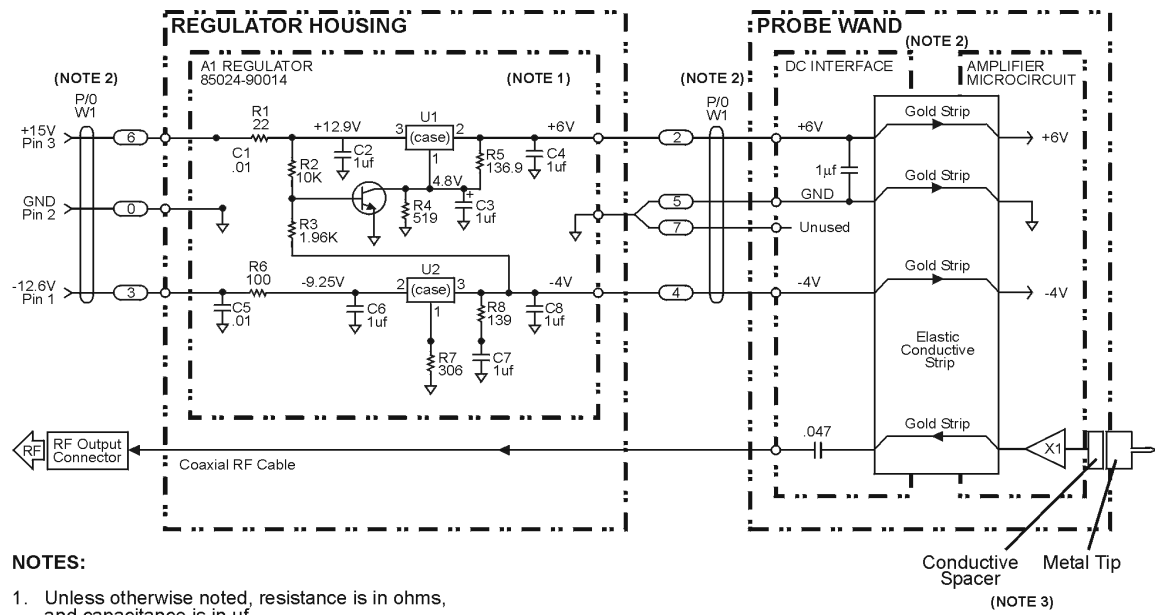

ao417a

**Figure 7-3 High Frequency Probe**

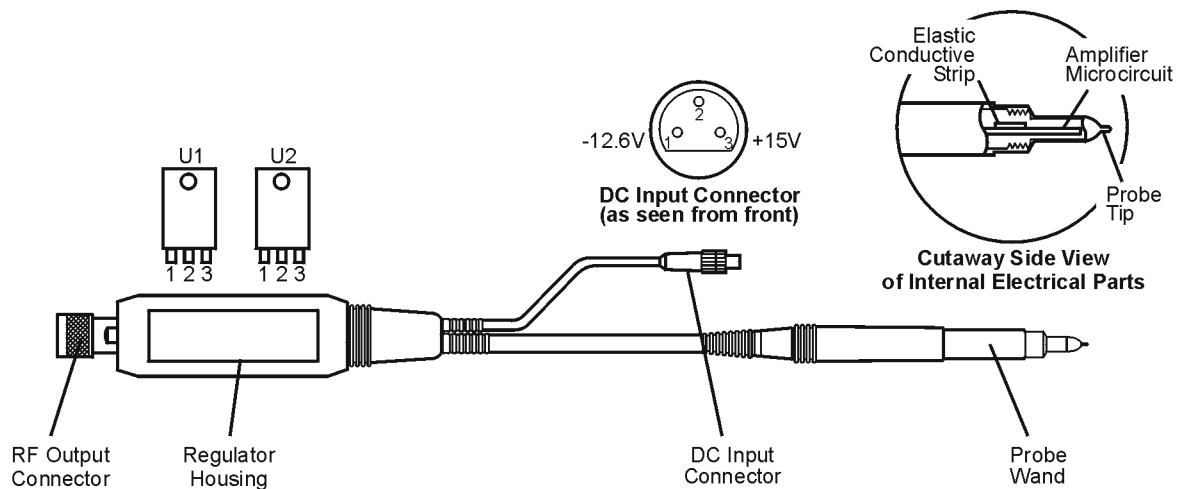

ao48a

3. Connect the probe's power cord to the power source. Turn the power source on.
4. Refer to [Figure 7-4](#). Check the +6 V and -4 V power supply voltages on the exposed portion of the probe end.
  - If the voltages are good, suspect an amplifier microcircuit failure. Replace the amplifier microcircuit and do *not* perform the following steps.
5. If one of these voltages is bad, follow the procedure in [“Removing the Plastic Regulator Housing Covers”](#) on page 7-10, and continue with the following steps.
6. Refer to [Figure 7-4](#). Disconnect the power supply cable and check the continuity of the three input lines to the A1 regulator assembly. If one of the wires is broken internally, replace the cable/probe wand assembly.
7. If the three input lines show continuity, desolder the -4 V and +6 V output wires shown in [Figure 7-4](#). Measure the +6 V and -4 V feed throughs on the printed circuit board. If the voltages are good replace the cable/probe wand assembly. If one of the voltages is bad, troubleshoot the A1 regulator board. Refer to [Figure 7-5](#) and [Figure 7-2](#) for a component location diagram and schematic diagram, respectively.

**Figure 7-4 Power Supply Check Points**

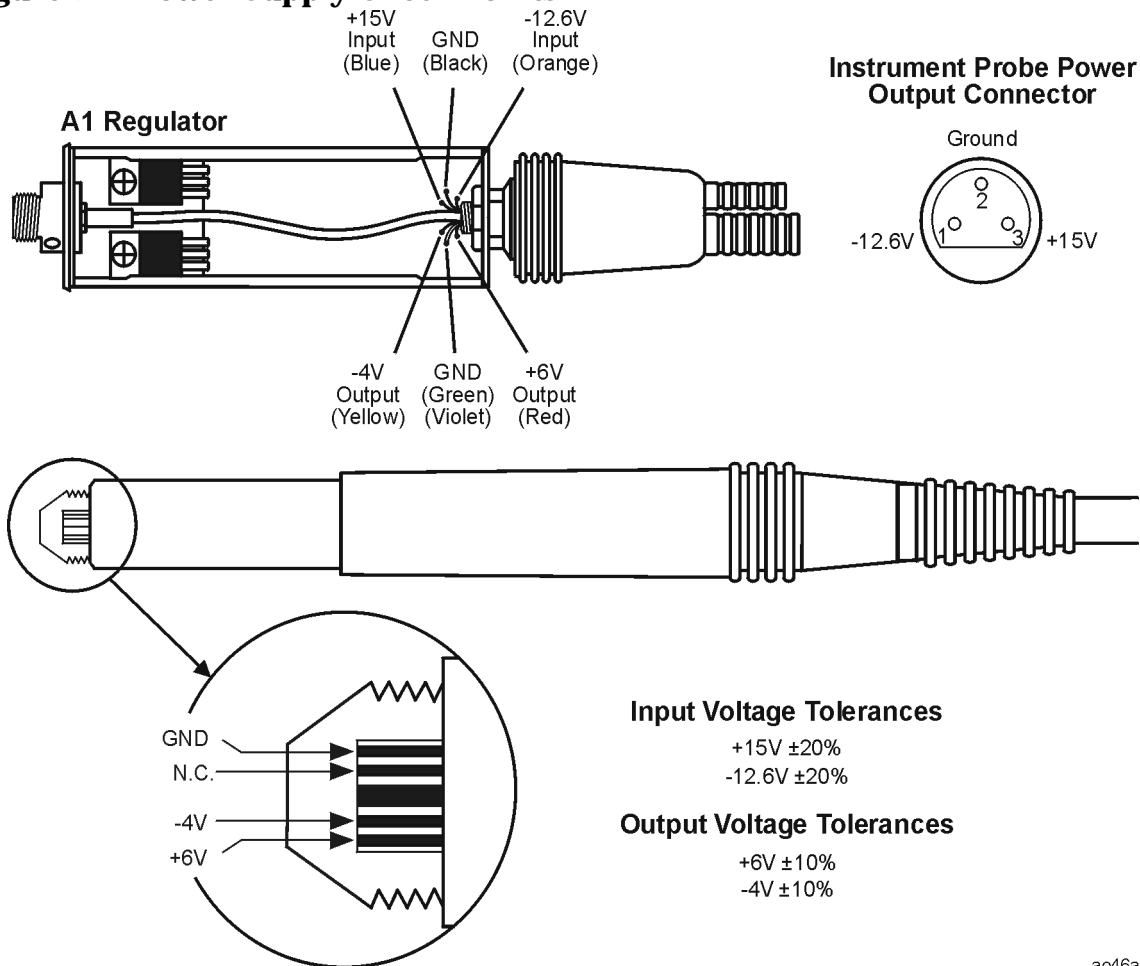

ac46a



**Figure 7-5 A1 Regulator Assembly Component Locations Diagram**

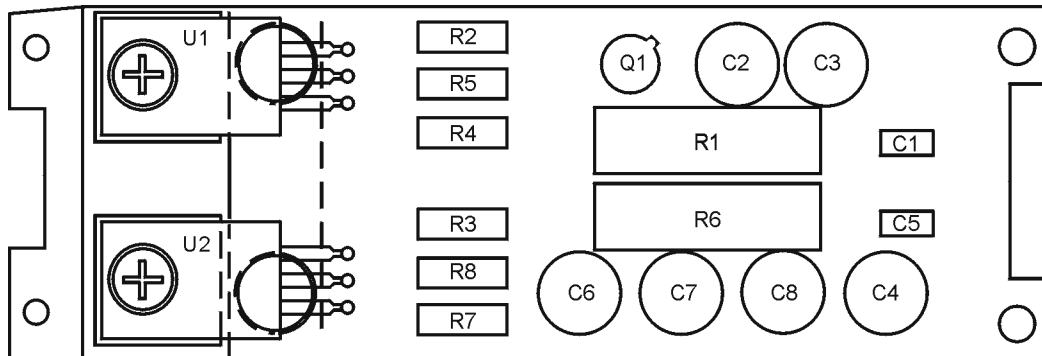

ao47a

---

## Replacement Procedure

### Replacing the Probe Tip

#### Tools Required:

- 3/32 inch probe-tip nut driver (supplied with the probe)
- 10 mm open-end wrench

---

**CAUTION** Use static precautions when performing the following procedures. The amplifier microcircuit is very static sensitive and exposed during this procedure.

---

Refer to *Figure 7-6*.

1. Remove the nut with a 10 mm open-end wrench.
2. Remove the nose assembly, leaving the microcircuit attached to the body of the probe.

---

**CAUTION** Failure to remove the nose assembly prior to replacing the tip will result in damage to the conductive elastometer on the tip assembly.

---

3. Unscrew the damaged tip with the nut driver and discard the tip.
4. Screw in the new tip and lightly tighten it with a 3/32 inch nut driver.  
(Overtightening the tip can damage the nose assembly.)
5. Install the nose assembly and nut. Tighten the nut with a 10 mm open-end wrench.

---

**NOTE** The tip on the 10:1 divider can be replaced without disassembling the divider. Use the 3/32 inch probe tip driver.

---

**Figure 7-6 Probe End Disassembly**

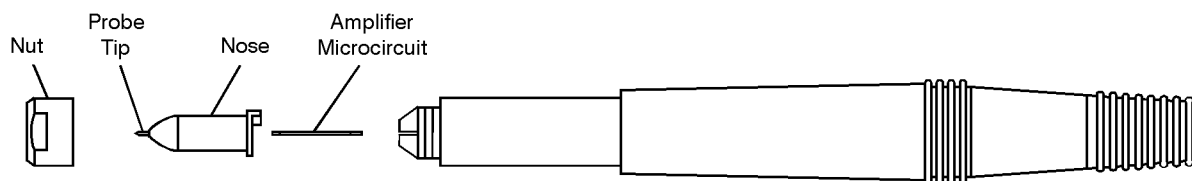

pl31a

## Replacing the Amplifier Microcircuit

### Tools Required:

- 10 mm open-end wrench
- Small flatblade screwdriver

Refer to [Figure 7-6](#).

1. Remove the nose assembly.
2. Remove the amplifier microcircuit.

Refer to [Figure 7-7](#).

3. Remove and discard the spring clip and elastic conductive strip.
4. Place the new amplifier microcircuit into the probe heatsink. Place the new elastic conductive strip in place, making sure the gold traces are facing down and are aligned lengthwise with respect to the probe. Make sure the elastic strip is flush with the front end of the heatsink. The screwdriver may be used to move the strip.
5. Place the new spring clip over the elastic strip, flush with the front of the heatsink. The beveled end of the clip should face away from the amplifier microcircuit. The center of this U-shaped clip must press into the elastic conductor. Insert one side of the clip into the small slot in the probe heatsink. Press the other side of the clip down with the small screwdriver until it snaps into the slot on the other side of the heatsink.
6. Replace the nose assembly and nut.

---

**CAUTION** Failure to remove the nose assembly prior to replacing the tip will result in damage to the conductive elastomer on the tip assembly.

---

**Figure 7-7 Probe Wand Components**

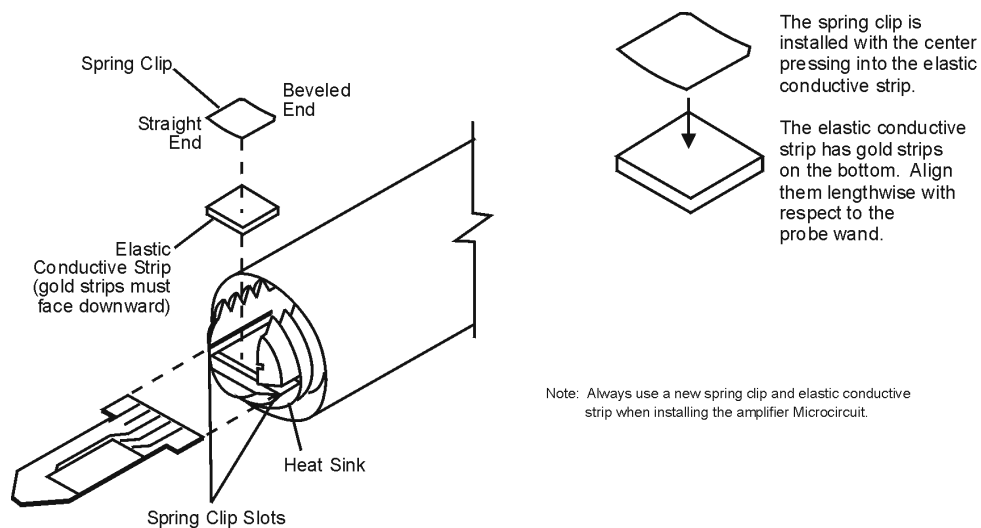

ao418a

## Removing the Plastic Regulator Housing Covers

### Tools Required:

1/8 inch-wide flatblade screwdriver

---

**WARNING** In the steps below, hold the regulator housing and screwdriver so that you won't injure yourself if the screwdriver slips.

---

Refer to [Figure 7-8](#).

1. Hold the regulator assembly by one end and insert the head of a 1/8 inch-wide flatblade screwdriver into the seam at the other end. The seam separates the two halves of the housing cover. Twist the screwdriver 90°.
2. Perform step 1 in several places along the four pry points shown in [Figure 7-8](#).

### Reassembling the Covers

3. Replace the metal housing reinforcement and plastic covers as show in [Figure 6-1 on page 6-5](#). The reinforcement is very important; it ensures that the covers will not pop off if the unit is dropped.

**Figure 7-8 Cover Removal**

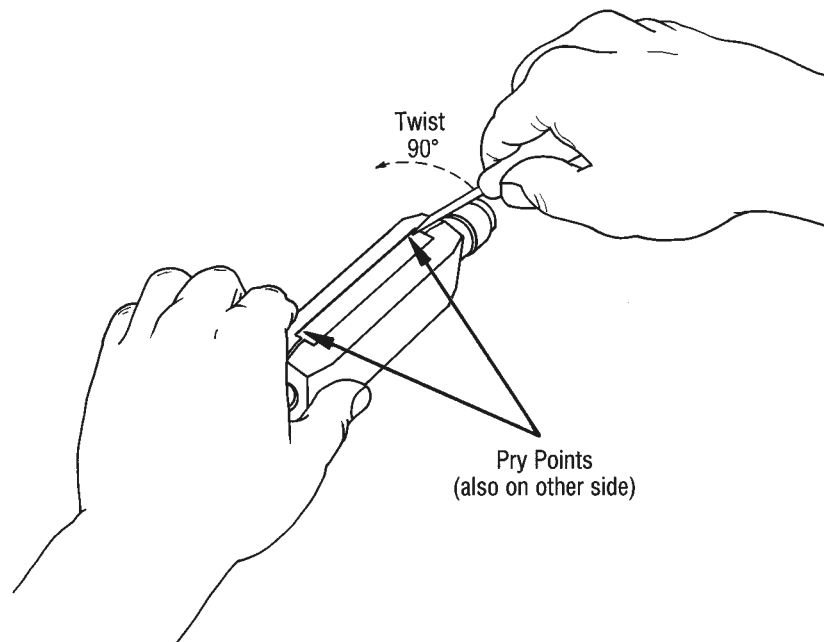

ao415a

## Replacing the Type-N Output Connector

### Tools Required:

9/16 inch open-end wrench

Refer to [Figure 7-9](#).

1. Remove the connector body with the open-end wrench.
2. Remove the male center conductor assembly from the gold plated inner connector. Use your fingers to pull out the assembly. The small insulator may or may not come out attached to the center conductor assembly. If it does, remove it from the old center conductor assembly and place it on the new one. If it is not attached to the center conductor assembly (it remained inside the inner connector), proceed to step 3.
3. Hold the new center conductor assembly by the large round insulator, not by the gold plated center conductor. Carefully align the new center conductor and insert it into the inner connector. Press gently until you feel it click into place.
4. Place the new connector body and tighten with the open-end wrench.

**Figure 7-9 Output Connector Parts**

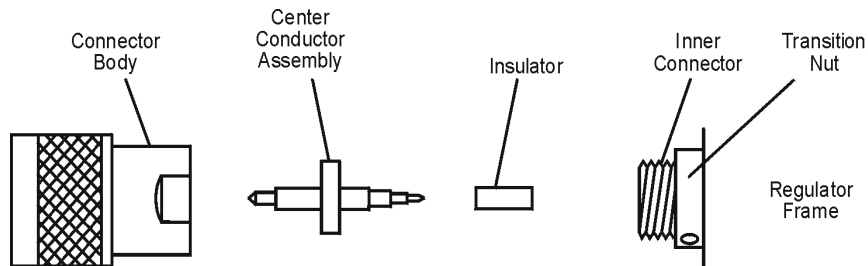

ao412a

---

**NOTE** Refer to [“Replaceable Parts”](#) on page 6-4 for part numbers.

---

## Cable/Probe Wand Replacement

### Tools Required:

- 10 mm open-end wrench
- 9/16 inch open-end wrench
- 1/8 inch-wide flatblade screwdriver
- Phillips No. 0 or posidrive screwdriver
- Long-nose pliers

### Special Tool:

- Spanner/wrench (part number 85024-20041)
- This special tool is pictured in [Figure 7-10 on page 7-13](#).

Refer to [Figure 7-6](#).

1. Remove the nut with a 10 mm open-end wrench.
2. Remove the nose assembly and set aside.

---

**CAUTION** The amplifier microcircuit is very sensitive to static electricity. Exercise full anti-static precautions and use great care when performing the procedure.

---

Refer to [Figure 7-7](#).

3. Remove the amplifier microcircuit. Remove the spring clip and elastic conductive strip. Place the microcircuit in a static-safe place. It will be needed later in this procedure.
4. Remove the regulator housing covers by performing the procedure in "[Removing the Plastic Regulator Housing Covers](#)" on page 7-10

Refer to [Figure 7-9](#).

5. Remove the connector body with the 9/16 inch wrench.

Refer to [Figure 7-11](#).

6. Remove the four screws which hold in the regulator assembly. Desolder the colored wires attached to the regulator assembly and remove the regulator assembly.
7. Remove the transition nut with the transition nut spanner (shown in [Figure 7-10](#)) and pull the inner connector out of its keyed hole.
8. Unscrew the inner connector from the RF cable. Hold the nut with long nose pliers while turning the connector.
9. Remove the hex nut with the special cable nut wrench (shown in [Figure 7-10](#)). The cable will now come loose.
10. Insert the new cable into the regulator frame and attach the hex nut.
11. Make sure the insulator (shown in [Figure 7-9](#)) is inside the connector.

12. Screw the inner connector onto the new RF cable and insert the inner conductor into the keyed hole.
13. Attach the transition nut with the spanner wrench.
14. Screw on the connector body and tighten with the 9/16 inch wrench.
15. Solder the seven power supply wires onto the regulator assembly as shown in [Figure 7-11](#).
16. Attach the A1 regulator assembly to the metal frame with the four screws removed earlier. The long screws go into the heatsink end.
17. Replace the metal housing reinforcement and plastic covers. The covers and housing reinforcement are illustrated in the replaceable part chapter, in [Figure 6-1 on page 6-5](#).

Refer to [Figure 7-7](#).

18. On the new probe wand, place the amplifier microcircuit into the heatsink assembly. Place the elastic conductive strip in place, making sure the gold traces are facing down and are aligned lengthwise with respect to the probe. Make sure the elastic conductor is flush with the front of the heatsink. The screwdriver may be used to align the strip.
19. Place the spring clip over the conductive strip, flush with the front of the heatsink. The beveled end of the clip should face away from the front of the wand. The center of this U-shaped clip must press into the elastic conductor. Insert one side of the clip into the small slot in the probe heatsink. Press the other side of the clip down with the small screwdriver until it snaps into the other slot.

Refer to [Figure 7-6](#).

20. Replace the nose assembly and nut.

**Figure 7-10 Special Spanner/Wrench Tool and Area of Use**

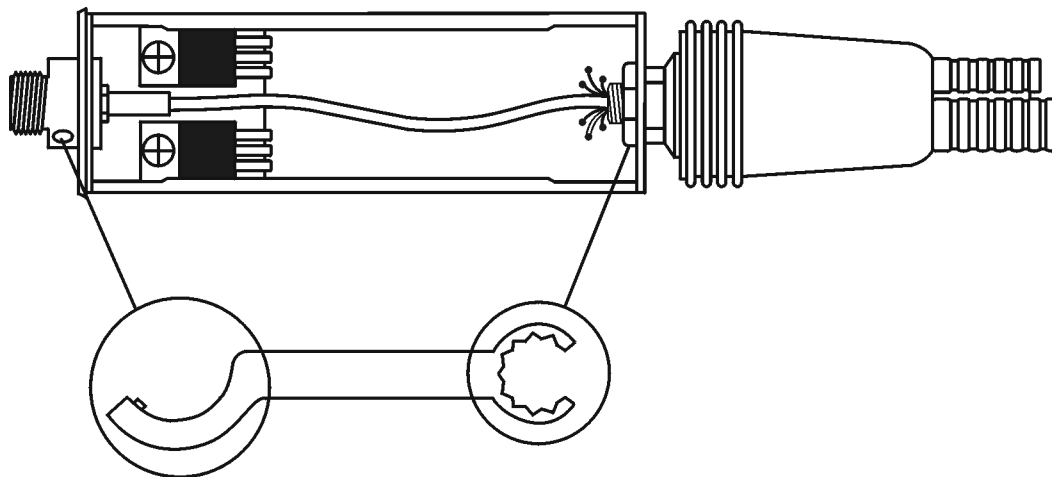

ao413a

**Figure 7-11 Regulator Parts and Wiring**

**A1 Regulator/Heat Sink (bottom view)**

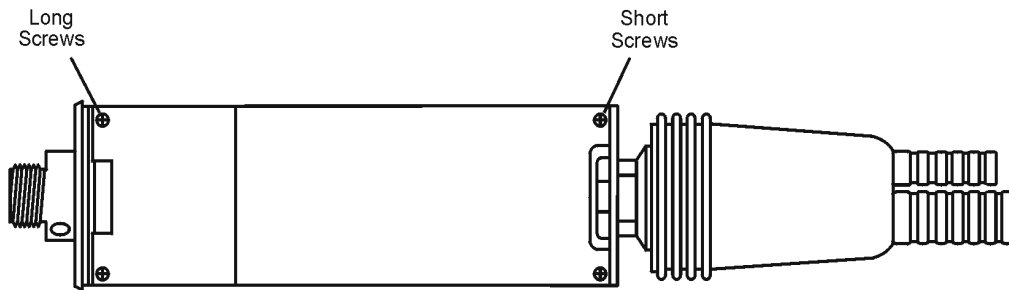

**A1 Regulator/Heat Sink (top view)**

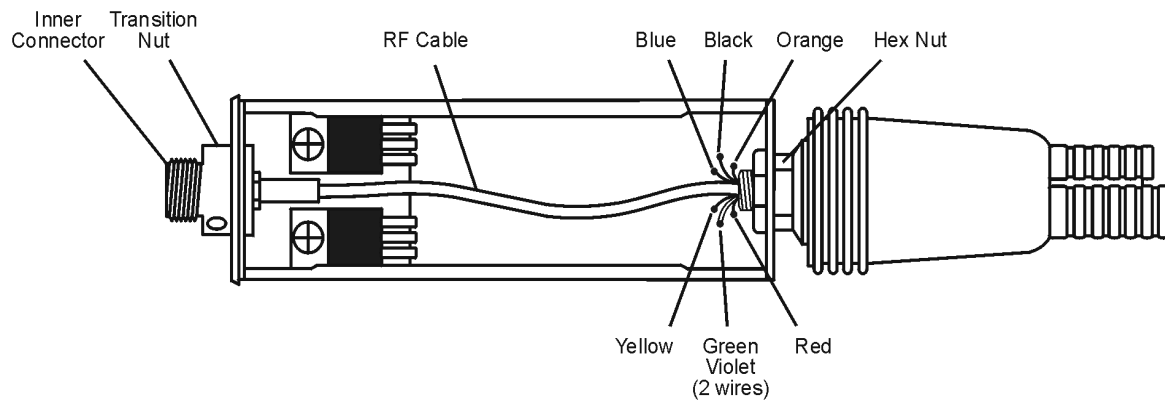

ao414a



---

## Connector Inspection and Cleaning

The following is a brief introduction to the fundamentals of proper connector care.

Proper connector care is essential to making accurate valid measurements.

### Inspecting the Connectors

Visual and mechanical inspection of the output connector and adapter should be done periodically.

---

**CAUTION** If a bad connector is accidentally attached to a good connector, the good connector can be damaged.

---

A connector is bad if one of the following conditions exist:

- It fails the visual examination.
- Connectors do not mate smoothly.

### Visual Examination

A careful visual inspection should be done often on all device connectors. Vigilance can save money and ensure the best measurements with your equipment.

Examine the connectors for such obvious problems as deformed threads, contamination, or corrosion, concentrating especially on the contacting surfaces. Look for burrs, scratches, rounded shoulders and similar signs of wear and damage. Any problem you can see is sufficient to cause degraded performance.

### Cleaning Connectors

---

**CAUTION** Always wear an anti-static wrist strap and work on an anti-static bench mat when cleaning the probe's outer connectors. Cleaning a connector requires you to touch the center conductor of the connector with a swab. The danger of introducing static electricity into the output connector center conductor must be completely eliminated. Do not clean the adapter when it is connected to the probe.

---

Clean connectors are essential for ensuring the integrity of RF and microwave coaxial connections. Use the following procedure to clean the connectors in this kit:

#### 1. Use Compressed Air or Nitrogen

Use compressed air (or nitrogen) to loosen particles on the connector mating plane surfaces. Clean air cannot damage a connector, or leave particles or residues behind.

---

**WARNING**     **Always use protective eyewear when using compressed air or nitrogen.**

---

You can use any source of clean, dry, low-pressure compressed air or nitrogen that has an effective oil-vapor filter and liquid condensation trap placed just before the outlet hose. Ground the hose nozzle to prevent electrostatic discharge, and set the air pressure to less than 414 kPa (60 psi) to control the velocity of the air stream. High-velocity streams of compressed air can cause electrostatic effects when directed into a connector.

## 2. Clean the Connector Threads

Use a lint-free swab or cleaning cloth moistened with isopropyl alcohol to remove any dirt or stubborn contaminants on a connector that cannot be removed with compressed air or nitrogen.

- a. Apply a small amount of isopropyl alcohol to the lint-free cleaning swab.
- b. Clean the connector threads.
- c. Let the alcohol evaporate, then blow the threads dry with a gentle stream of clean, low-pressure compressed air or nitrogen.

---

**WARNING**     **Isopropyl alcohol is extremely flammable, causes irritation, may cause eye damage, and is harmful if swallowed or inhaled. It may be harmful if absorbed through the skin. Keep away from heat, sparks, and flame. Avoid contact with eyes, skin, clothing. Avoid breathing vapor. Keep in tightly closed container. Use with adequate ventilation. Wash thoroughly after handling. In case of fire, use alcohol foam, dry chemical, or carbon dioxide: water may be ineffective. In case of spill, soak up with sand or earth. Flush spill area with water.**

**Dispose of isopropyl alcohol in accordance with all applicable federal, state, and local environmental regulations**

---

## 3. Clean the Mating Plane Surfaces

Apply a small amount of isopropyl alcohol to a new swab and clean the center and outer conductor mating plane surfaces. When cleaning a female connector, avoid snagging the swab on the center conductor contact fingers by using short strokes.

## 4. Dry the Connector

After cleaning, blow the connector dry with a gentle stream of clean compressed air or nitrogen. Always completely dry a connector before you reassemble or use it.

## 5. Reinspect

Inspect the connector again to make sure that no particles or residue are present.

**Table 7-1 Agilent Technologies Sales and Service Offices**

<b>UNITED STATES</b>		
Instrument Support Center Agilent Technologies (800) 403-0801		
<b>EUROPEAN FIELD OPERATIONS</b>		
Headquarters Agilent Technologies S.A. 150, Route du Nant-d'Avril 1217 Meyrin 2/ Geneva Switzerland (41 22) 780.8111	France Agilent Technologies France 1 Avenue Du Canada Zone D'Activite De Courtaboeuf F-91947 Les Ulis Cedex France (33 1) 69 82 60 60	Germany Agilent Technologies GmbH Agilent Technologies Strasse 61352 Bad Homburg v.d.H Germany (49 6172) 16-0
Great Britain Agilent Technologies Ltd. Eskdale Road, Winnersh Triangle Wokingham, Berkshire RG41 5DZ England (44 118) 9696622		
<b>INTERCON FIELD OPERATIONS</b>		
Headquarters Agilent Technologies 3495 Deer Creek Rd. Palo Alto, CA 94304-1316 USA (415) 857-5027	Australia Agilent Technologies Australia Ltd. 31-41 Joseph Street Blackburn, Victoria 3130 (61 3) 895-2895	Canada Agilent Technologies (Canada) Ltd. 17500 South Service Road Trans-Canada Highway Kirkland, Quebec H9J 2X8 Canada (514) 697-4232
Japan Agilent Technologies Japan, Ltd. Measurement Assistance Center 9-1, Takakura-Cho, Hachioji-Shi, Tokyo 192-8510, Japan TEL (81) -426-56-7832 FAX (81) -426-56-7840	Singapore Agilent Technologies Singapore (Pte.) Ltd. 150 Beach Road #29-00 Gateway West Singapore 0718 (65) 291-9088	Taiwan Agilent Technologies Taiwan 8th Floor, H-P Building 337 Fu Hsing North Road Taipei, Taiwan (886 2) 712-0404
China China Agilent Technologies 38 Bei San Huan X1 Road Shuang Yu Shu Hai Dian District Beijing, China (86 1) 256-6888		

## Numerics

- 1 dB compression, 5-6
- 10 to 1 divider, 2-5

## A

- A1 regulator assembly
  - replaceable parts, 6-6
- accessories, 2-1
- adapter, probe, 2-4
- anti-static precautions, 1-3
- average noise level, 5-8

## C

- cable/probe wand replacement, 7-12
- calibration, response, 5-4
- characteristics
  - 10 to 1 divider, 2-5
  - general, 1-6
  - high frequency probe, 1-5
  - probe adapter, 2-4
  - supplemental, 1-5
- cleaning
  - 10 to 1 divider, 2-5
  - connectors, 7-15
  - probe adapter, 2-4
- conditions, environmental, 1-6
- connector
  - cleaning, 7-15
  - inspection, 7-15
  - mating, 3-4
  - pin-outs, 3-3
  - type-N replacement, 7-11
  - visual examination, 7-15

## D

- description
  - 10 to 1 divider, 2-5
  - average noise level, 5-8
  - gain at 500 MHz/frequency response flatness, 5-5
  - gain compression, 5-6
  - median gain, 5-5
  - probe adapter, 2-4
- description, product, 1-4
- devices
  - grounding, 4-3
- divider, 10 to 1, 2-5

## E

- environmental conditions, 1-6
- environmental requirements, 1-6
- equipment
  - recommended test, 5-3

- equipment required for troubleshooting, 7-2
- equivalent power, 5-7
- external power supply, 3-3

## F

- failure
  - electrical, 7-4
  - mechanical, 7-4
  - protective sleeve, 7-4
- frequency response relative to 500 MHz, 5-5

## G

- gain at 500 MHz, 5-5
- gain compression, 5-6
- general information, 1-1
- grounding devices, 4-3

## H

- high frequency probe, 1-5

## I

- initial inspection, 3-2
- input voltage for 1 dB compression, 5-6
- input voltage tolerances, 1-2
- inspection
  - 10 to 1 divider, 2-5
  - initial, 3-2
  - probe adapter, 2-4
- installation, 3-1

## M

- mating connectors, 3-4
- measurement precautions, 1-2
- measurements, 5-4
- mechanical failure of the protective sleeve, 7-4
- median gain, 5-5

## N

- network analyzer
  - operation, 5-4
  - operator's check, 4-4
- noise level, average, 5-8

## O

- operating characteristics
  - 10 to 1 divider, 2-5
  - high frequency probe, 1-5
  - probe adapter, 2-4
- operating instructions, 4-3
  - discharging the probe, 4-3

- extending the protective sleeve, 4-3
- grounding the probe, 4-3
- retracting the protective sleeve, 4-3

- operating, precautions, 3-3
- operation, network analyzer, 4-1, 5-4
- operator's check, 4-4
  - network analyzer, 4-4
  - spectrum analyzer, 4-5

## P

- parts
  - identification, 6-5, 6-6
  - miscellaneous, 6-3
  - replaceable, 6-1, 6-5
- performance tests, 5-1
  - average noise level, 5-8
  - gain at 500 MHz/frequency response flatness, 5-5
  - input voltage for 1 dB compression, 5-6
  - median gain, 5-5
- pin-outs, power connector, 3-3
- power connectors, 3-3
- power supply
  - check, 7-4
  - external, 3-3
  - high frequency probe, 3-3
  - requirements, 3-3
- precautions
  - anti-static, 1-3
  - ESD, 1-3
  - measurement, 1-2
  - operating, 4-2
- preparation for use, 3-3
- probe
  - adapter, 2-4
  - check power supply, 7-4
  - discharging between measurements, 4-3
  - electrical failure, 7-4
  - grounding, 4-3
  - inspection, 2-4
  - mechanical failure, 7-4
  - sleeve, 4-3
  - tip replacement, 2-6, 7-8
  - visually inspect the tip, 7-4
- probe power supply requirements, 3-3
- procedure
  - average noise level, 5-8
  - gain at 500 MHz/frequency response flatness, 5-5
  - gain compression, 5-6

- input voltage for 1 dB
  - compression, 5-6
- median gain, 5-5
- operator's check, 4-4
- operator's check using a network analyzer, 4-4
- operator's check using a spectrum analyzer, 4-5
- replacement, 7-8
- troubleshooting, 7-4
- product
  - 10 to 1 divider, 2-5
  - probe adapter, 2-4
- product description, 1-4
  - average noise level, 5-8
  - gain at 500 MHz/frequency response flatness, 5-5
  - gain compression, 5-6
  - median gain, 5-5
  - probe adapter, 2-4
- product performance, 1-5
- protective sleeve
  - extension of, 4-3
  - retraction of, 4-3
- R**
  - recommended test equipment, 5-3
  - repair strategy, 7-2
    - main cable and plastic sleeve guide, 7-2
    - probe tip and amplifier microcircuit, 7-2
  - replaceable parts, 6-1, 6-4
    - A1 regulator assembly, 6-6
    - adapter, 2-6
    - probe, 2-4, 2-6, 6-4
  - replacement procedure, 7-8
    - amplifier microcircuit, 7-9
    - cable/probe wand, 7-12
    - plastic regulator covers and housing, 7-10
    - probe tip, 2-6, 7-8
    - type-N connector, 7-11
  - required equipment for troubleshooting, 7-2
  - requirements
    - environmental, 1-6
  - response calibration, 5-4
  - returning the product for service, 3-5
- S**
  - S21 measurement, 5-4
  - safe DC input voltage, 1-5
  - safe RF input voltage, 1-5
  - service, 7-1, 7-17
  - settings
    - frequency range, 5-4
    - output power, 5-4
    - power meter, 5-4
    - specifications, product performance, 1-5
    - spectrum analyzers, operator's check, 4-5
    - supplemental characteristics, 1-5
- T**
  - test equipment, 5-3
  - test procedure
    - average noise level, 5-8
    - gain at 500 MHz/frequency response flatness, 5-5
    - input voltage for 1 dB
      - compression, 5-6
    - median gain, 5-5
    - operator's check using a network analyzer, 4-4
    - operator's check using a spectrum analyzer, 4-5
  - test record, 5-9
  - tests, performance, 5-1
  - theory of operation, 7-3
  - tolerances
    - electrical, 1-5
    - input voltage, 1-2, 1-5
  - transmission measurement, 5-4
  - troubleshooting, 7-1, 7-4
    - electrical failure, 7-4
    - mechanical failure of the protective sleeve, 7-4
    - power supply, 7-4
    - visual inspection of the probe tip, 7-4
  - troubleshooting and repair, 7-1
  - troubleshooting equipment, 7-2
  - troubleshooting procedure
    - mechanical failure of the protective sleeve, 7-4
    - power supply, 7-4
    - visually inspect the probe tip, 7-4
  - type-N output connector
    - replacement, 7-11
- V**
  - visually inspect the probe tip, 7-4
  - voltage
    - input tolerances, 1-2, 1-5
    - max safe DC input, 1-2, 1-5
    - max safe RF input, 1-2, 1-5
- W**
  - warranty, ii