



Installation Note

Rack Mounting the Agilent E840xA Mainframe

This installation note contains procedures for mounting an Agilent E840xA C-Size VXI mainframe in a standard EIA rack using one of the following:

- Agilent E3663AC Support Rail Kit
- Agilent E3664AC Support Rail Kit
- 1494-0411 Rack Slide Kit.

Installing a Mainframe in Non-Agilent Racks

See page 13 for a procedure to install a mainframe in a non-Agilent rack using the Option AXD VXIplug&play Compliant Adapter Kit.

Installing a Cable Tray

See page 15 for instructions to mount the cable tray to the mainframe.

Table 1 shows the mainframe adapter options used with the support rail and rack slide kits. When rack mounting the mainframe you must order an adapter option **and** the rail **or** rack slide kit supported by the adapter.

Table 1. Agilent E840xA Rack Mount Options and Kits.

Rack Mount Adapter Options	1st Designation (obsolete)	2nd Designation (obsolete)	Current Designation (ordered with mainframe)	Agilent Service P/N	Rail and Rack Slide Kits
Agilent E840xA Standard Adapter Kit	Option 923	E8400-60003	Option AXA	E8400-80923	Support Rail Kit E3664AC or Rack Slide Kit 1494-0411
Agilent E840xA Flush Mount Adapter Kit	Option 924	E8400-60004	Option AXB	E8400-80924	Support Rail Kit E3664AC
Agilent E840xA VXIplug&play Compliant Adapter Kit (Agilent racks only)	Option 925	E8400-60005	Option AXC	E8400-80925	Support Rail Kit E3663AC* or Rack Slide Kit 1494-0411
Agilent E840xA VXIplug&play Compliant Adapter Kit (Non-Agilent racks)	Option 926	E8400-60008	Option AXD	E8400-80926	Rack Slide Kit 1494-0411 with required End Bracket Kit p/n 1494-0064
Tinted Acrylic Door	Option 915	E8400-69301	---	E8400-80915	---
Cable Tray Kit	Option 914	---	---	E8400-60006	---

* This adapter kit can also be used with the Agilent E3665AC rail kit.

Parts List

The parts included with each rack mount adapter option and the support rail and rack slide kits are shown in Table 2.

Table 2. Optional Rack Mount Adapters, Support Rail, and Rack Slide Parts Lists.

Quantity	Description	Part Number
Option AXA - Agilent E840xA Standard Adapter (kit p/n E8400-80923)		
1	Rack Mount Adapter (left)	E8400-61203
1	Rack Mount Adapter (right)	E8400-61204
2	Handles (AMATOM mfr p/n)	10939-A-032-2
4	Handle Screws - 10-32 x 0.375 flat head	2680-0100
8	Adapter-to-Mainframe Screws - 10-32 x 0.312 pan head	2680-0129
4	Adapter Dress Screws	0570-1577
4	Channel Nuts (for adapter dress screws)	0590-0804
Option AXB - Agilent E840xA Flush Mount Adapter (kit p/n E8400-80924)		
1	Rack Mount Adapter (left)	E8400-61205
1	Rack Mount Adapter (right)	E8400-61206
4	Adapter-to-Mainframe Screws - 10-32 x 0.312 pan head	2680-0129
4	Adapter Dress Screws	0570-1577
4	Channel Nuts (for adapter dress screws)	0590-0804
Option AXC - Agilent E840xA VXIplug&play Compliant Adapter (kit p/n E8400-80925)		
1	Rack Mount Adapter (left)	E8400-61207
1	Rack Mount Adapter (right)	E8400-61208
4	Fixture Screws - 10-32 x 0.5 flat head	2680-0104
8	Adapter-to-Mainframe Screws - 10-32 x 0.312 pan head	2680-0129
6	Adapter Dress Screws	0570-1577
6	Channel Nuts (for adapter dress screws)	0590-0804
Option AXD - (same as Option AXC for use with Non-Agilent Racks) (kit p/n E8400-80926)		
1	Rack Mount Adapter (left)	E8400-61209
1	Rack Mount Adapter (right)	E8400-61210
1	Spacer	E8400-04702
4	Fixture Screws - 10-32 x 0.5 flat head	2680-0104
4	Adapter-to-Mainframe Screws (L) - 10-32 x 0.5 pan head	2680-0103
4	Adapter-to-Mainframe Screws (R) - 10-32 x 0.375 pan head	2680-0099
6	Adapter Dress Screws	0570-1577
6	Channel Nuts (for adapter dress screws)	0590-0804

Table 2. Optional Rack Mount Adapters, Support Rail, and Rack Slide Parts Lists.

Quantity	Description	Part Number
Support Rails (Agilent E3664AC)		
2	Support Rails	E3664-00001
4	Channel Nuts (for support rail-to-rack)	0590-0804
4	Support Rail-to-Rack Screws - 10-32 x 0.5	2680-0103
Rack Slides (Agilent p/n 1494-0411)		
2	Rack Slides (General Devices mfr p/n)	CC1502-99-0016
8	Rack Slide-to-Adapter Screws - 10-32 x 0.312 flat head	2680-0275
8	Channel Nuts (for slide rails)	0590-0804
4	Rack Slide-to-Rack Front Screws - 10-32 x 0.5 flat head	2680-0104
4	Rack Slide-to-Rack Rear Screws - 10-32 x 0.5 pan head	2680-0103

Rack Mounting the Agilent E840xA using Support Rails

This section contains instructions for mounting the mainframe in an Agilent EIA rack cabinet using the Agilent E3664AC or Agilent E3663AC support rail kit. Use the E3664AC rail kit with the Option AXA standard or Option 924 flush-mount rack mount adapter kits. Use the Agilent E3663AC Support Rail Kit when installing the Option AXC VXIplug&play Compliant Adapter Kit. The following procedures apply to the above mentioned adapters, with adapter-specific information noted where necessary.

Note If you ordered the cable tray, refer to page 15 and install the tray before rack mounting the mainframe.

Procedure

1. Attach the handles to the adapters using the 10-32 x 0.375 flat head screws (Figure 1). Handles are included only with the Standard adapters (Option AXA).

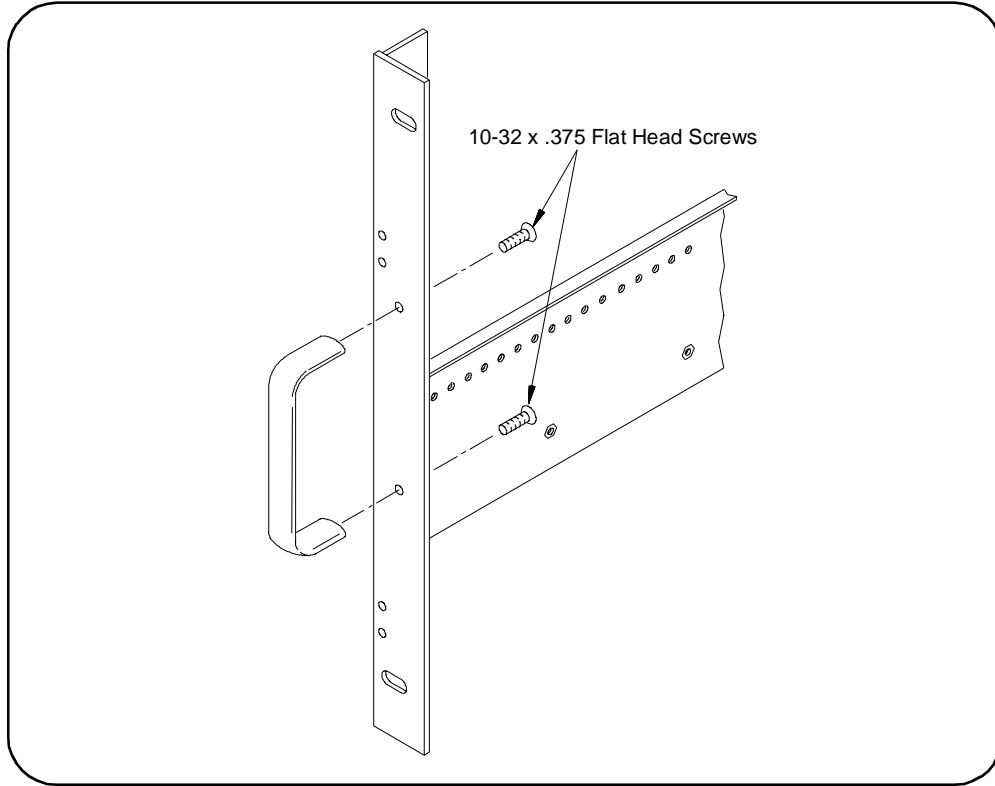

Figure 1 . Attaching Handles to the Adapters (Option AXA - kit p/n E8400-80923).

2. Using the rack mount adapters as templates, position the adapters on the rack's vertical columns where the mainframe is to be mounted. Align the adapter holes over the "center" holes of the EIA rack units (Figure 2).

Note

If you are using the VXIplug&play Compliant adapters (Option AXC or Option AXD), position the adapters such that all three mounting holes are directly over holes on the rack's vertical columns, and that the adapter flanges cover nine full EIA rack units with no overlap.

3. Slide channel nuts over the rack holes to be used by the rack mount adapters.

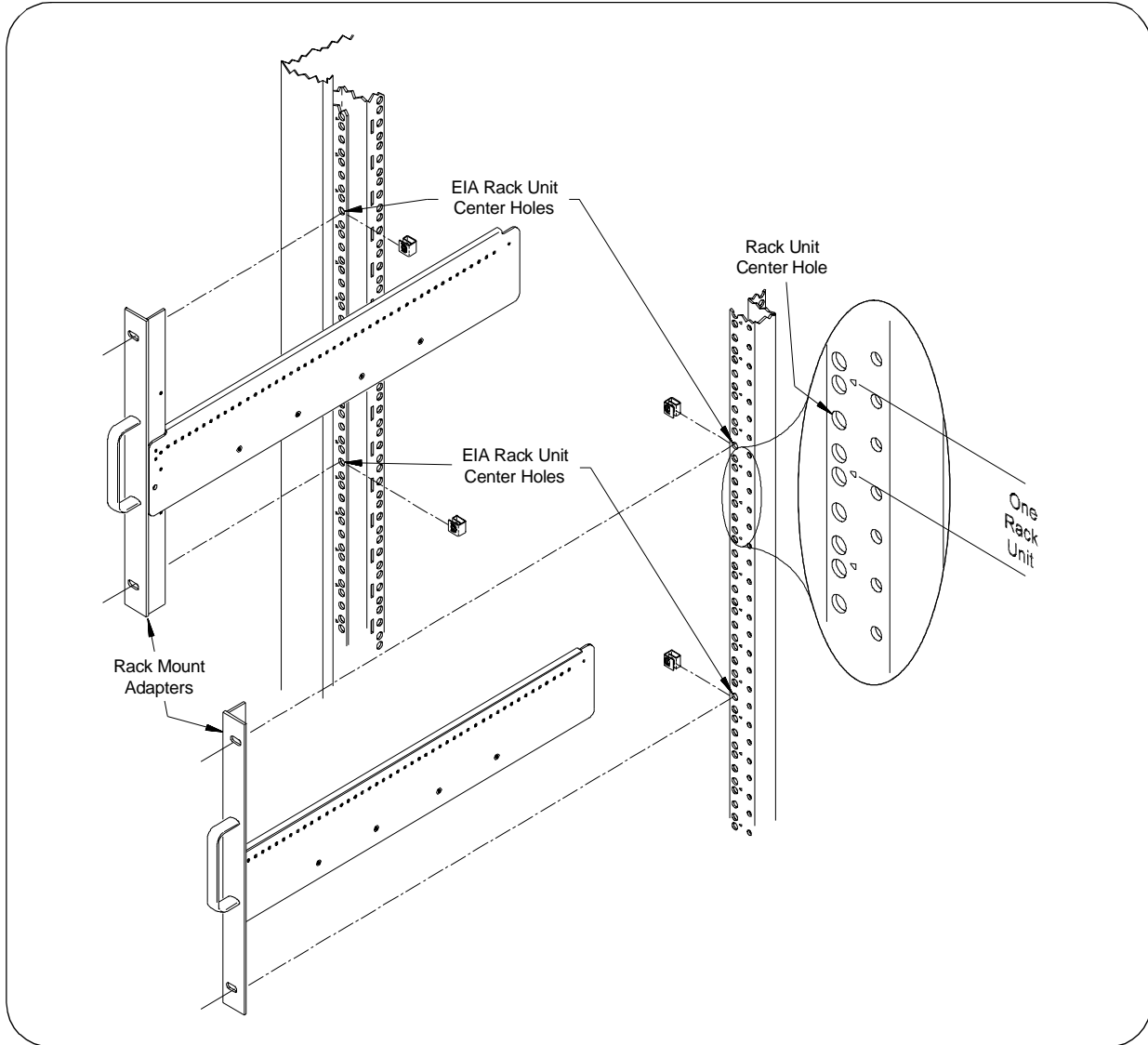

Figure 2 . Positioning the Mainframe in the Rack.

4. Attach the support rails to the rack's inside vertical columns. The support rails must be positioned in the **bottom** EIA rack unit for Options AXA or AXB, or in the second EIA rack unit up from the bottom for Option AXC. Use four channel nuts and the four 10-32 x 0.5 support rail-to-rack pan head screws to secure the rails as shown in Figure 3.

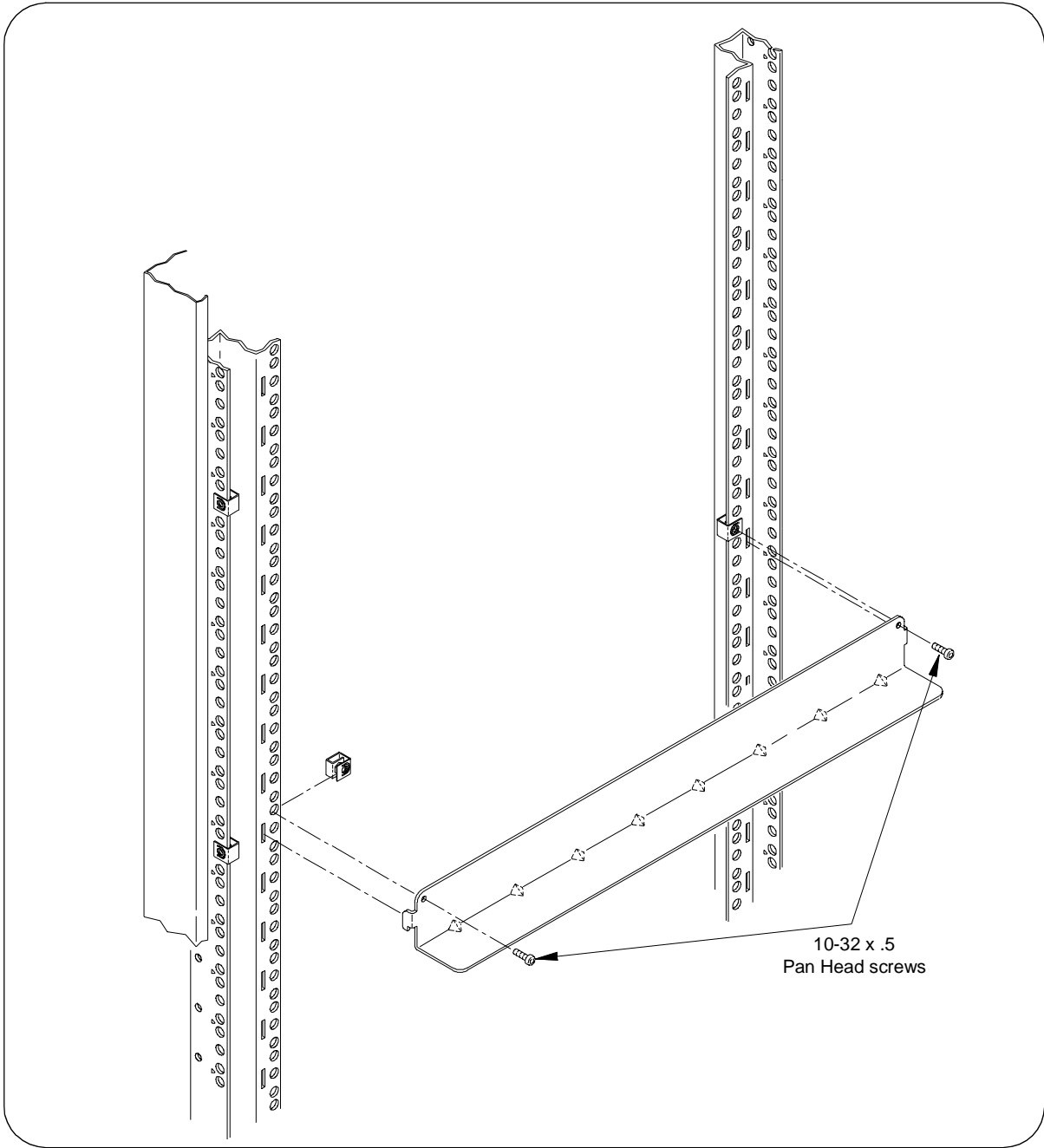

Figure 3 . Attaching the Support Rails to the Rack.

5. Attach the rack mount adapters to the mainframe using the 10-32 x 0.312 pan head screws provided.

With the standard adapters (Option AXA), the mainframe can be recess mounted up to 270.7 mm (10.6 inches), or extended out from the rack up to 147.6 mm (5.8 inches) in 12.3 mm (approximately 1/2 inch) increments. Be sure a minimum of three screws are used to mount the adapters. To mount the mainframe flush with the rack front, begin with the third (3rd) hole from the front of the adapter (Figure 4).

The rack mount adapters for the VXI compliant and flush mount options are also shown in Figure 4.

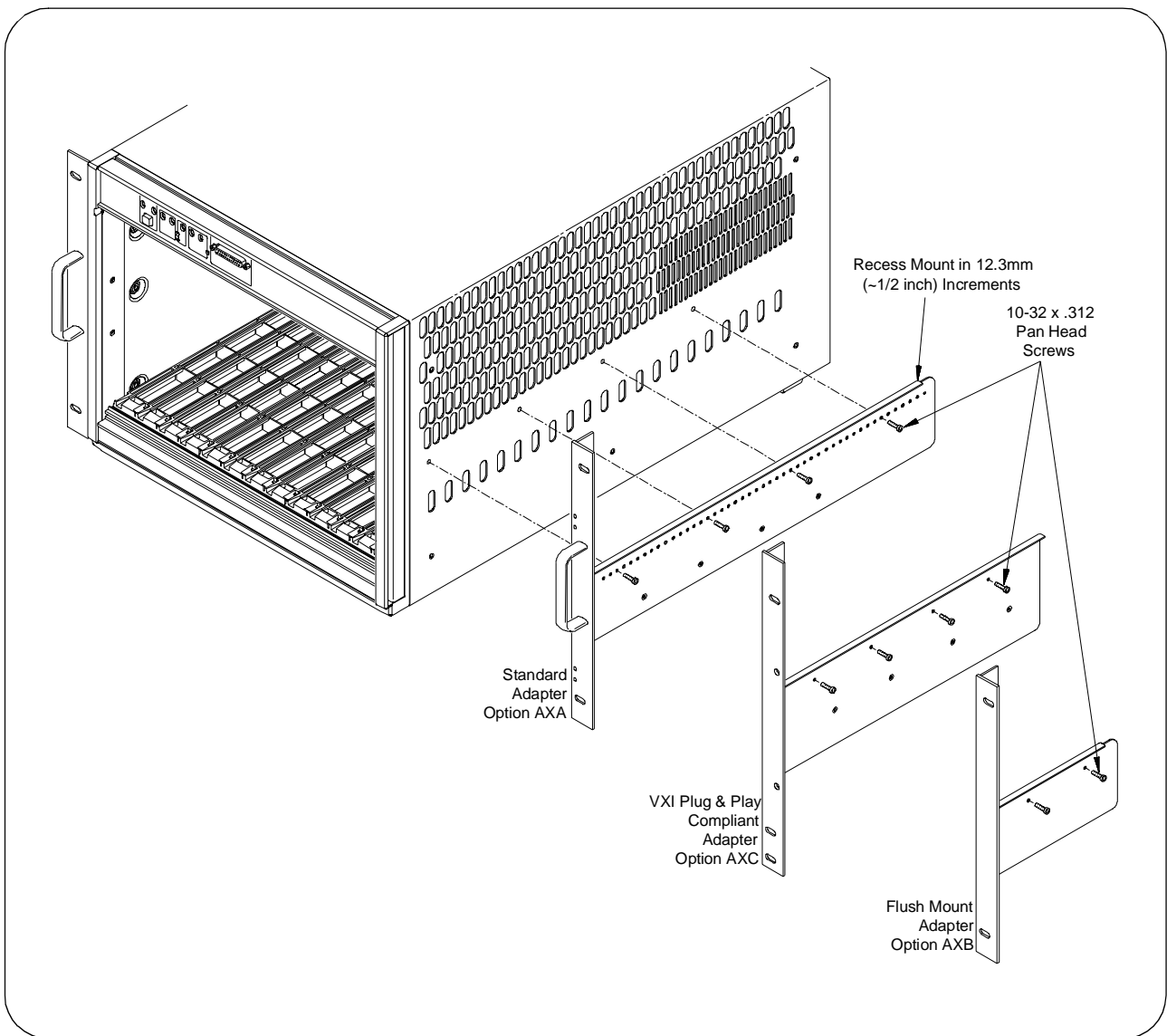

Figure 4 . Attaching the Rack Mount Adapter to the Mainframe.

6. Remove the mainframe feet by lifting the tabs and sliding the feet towards the center of the mainframe.
7. With one person on each side of the mainframe, lift the mainframe onto the support rails. Slide the mainframe into the rack until the rack mount adapter flanges are against the rack's vertical columns. Secure the mainframe to the rack using the adapter dress screws.

WARNING To prevent injury during rack mounting, the mainframe should be empty and two people should lift the mainframe into the rack.

Rack Mounting the Agilent E840xA Using Rack Slides

This section contains instructions for mounting the mainframe in an Agilent EIA rack cabinet using the rack slide kit (p/n 1494-0411). The rack slide kit, which is used with either the Standard adapters (Option AXA) or the VXIplug&play Compliant adapters (Option AXC), allows you to extend the mainframe from the cabinet for easier access to installed instruments.

The following procedures apply to the adapter kits listed above with adapter-specific information noted where necessary. The rack slide kit is not used with the flush mount adapters (Option AXB). Instructions for using Option AXD in a non-Agilent rack cabinet are provided on page 13.

Procedure

1. Attach the handles to the standard adapters using the 10-32 x 0.375 flat head screws (Figure 5). Handles are included only with the Standard adapters (Option AXA).

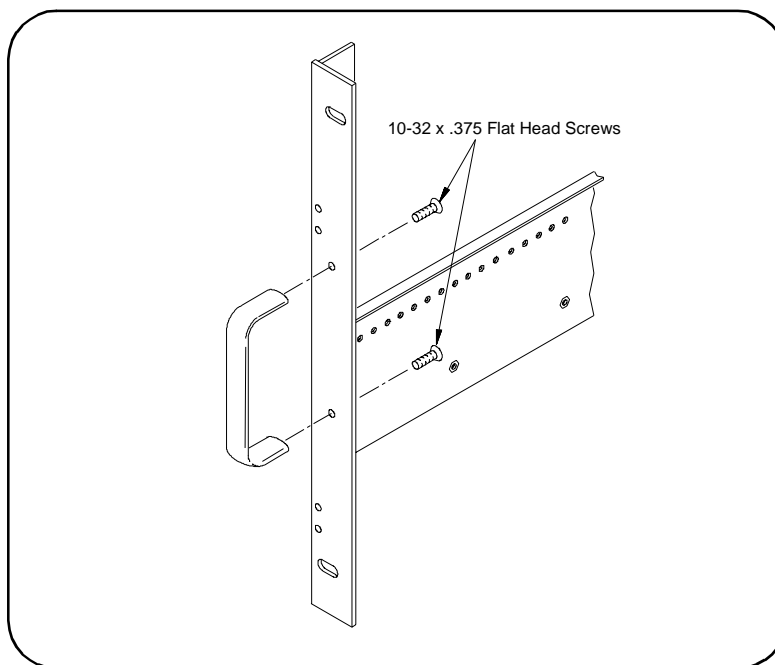

Figure 5 . Attaching Handles to the Adapters (Option AXA - kit p/n E8400-80923).

2. Using the rack mount adapters as templates, position the adapters on the rack's vertical columns where the mainframe is to be positioned. Be sure to align the adapter flange holes over EIA unit center holes on the vertical columns (Figure 6).

If you are using the VXIplug&play Compliant adapters (Option AXC), position the adapters such that all three mounting holes are directly over holes on the rack's vertical rails, and that the adapter flanges cover nine full EIA rack units with no overlap.

3. Slide channel nuts over the rack holes to be used by the rack mount adapters.

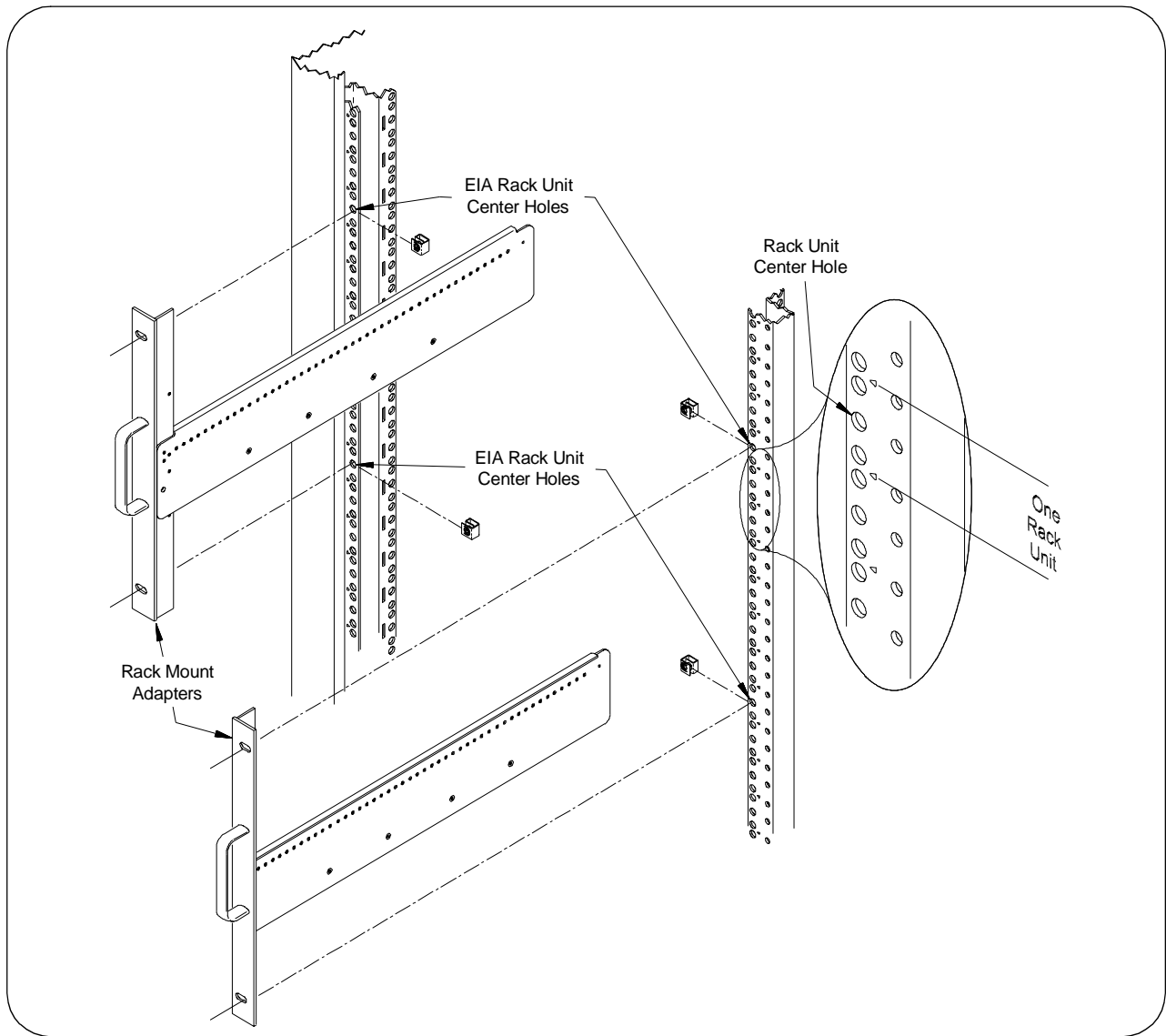

Figure 6 . Positioning the Mainframe in the Rack.

4. position the rack slides in the rack cabinet. For Option AXA use the 15th and 19th hole down from the top of the 8U space. For Option AXC use the 13th and 16th hole down from the top of the 9U space. Slide channel nuts over the corresponding holes on the inside vertical columns, left and right, front and rear (see Figure 7).

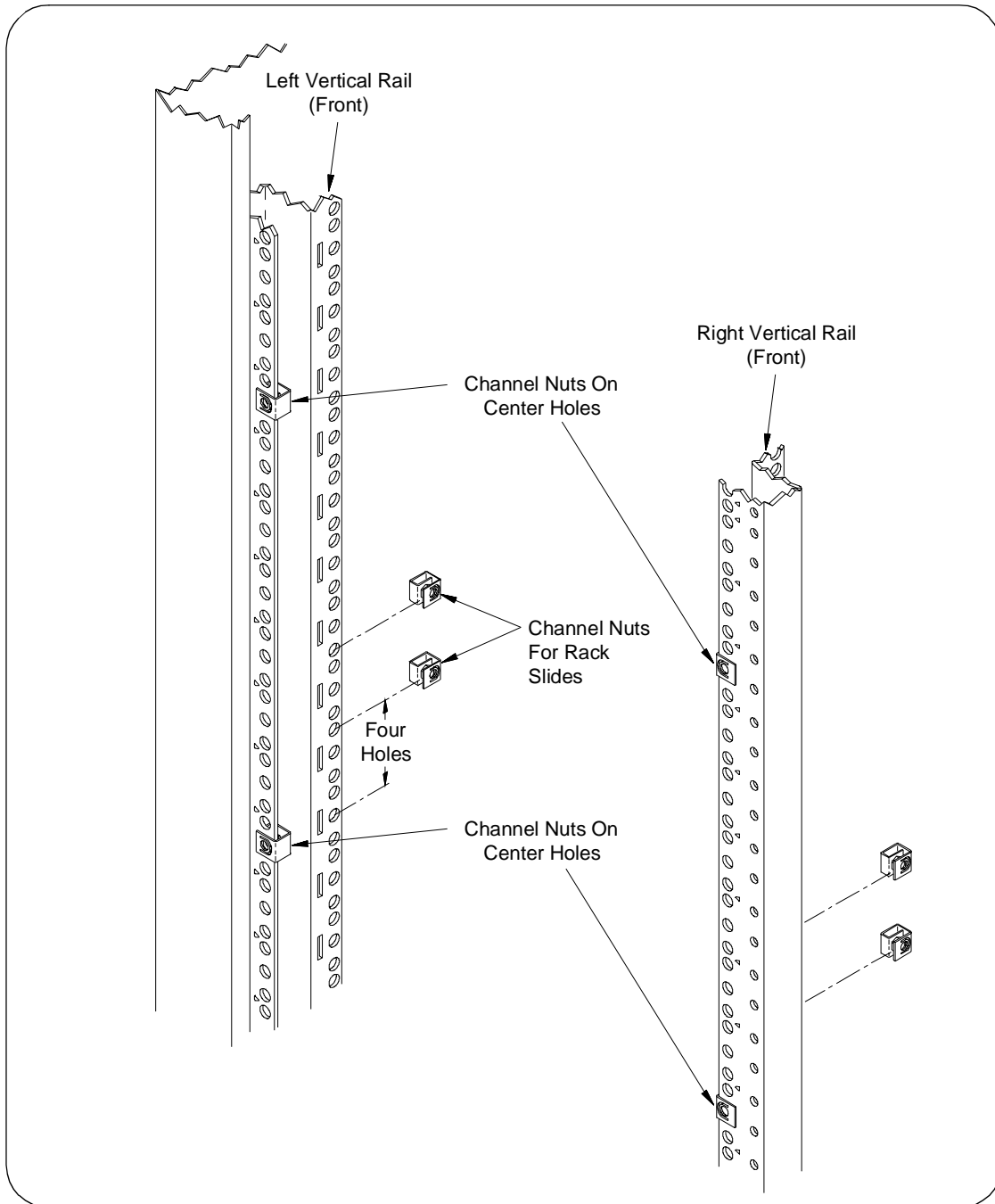

Figure 7 . Positioning the Rack Slides (Option AXA - standard adapters shown).

- Remove the rack slide chassis section from the intermediate section (Figure 8). (The chassis section will be connected to the mainframe in Step 7.) Slide the intermediate section back into the stationary section.

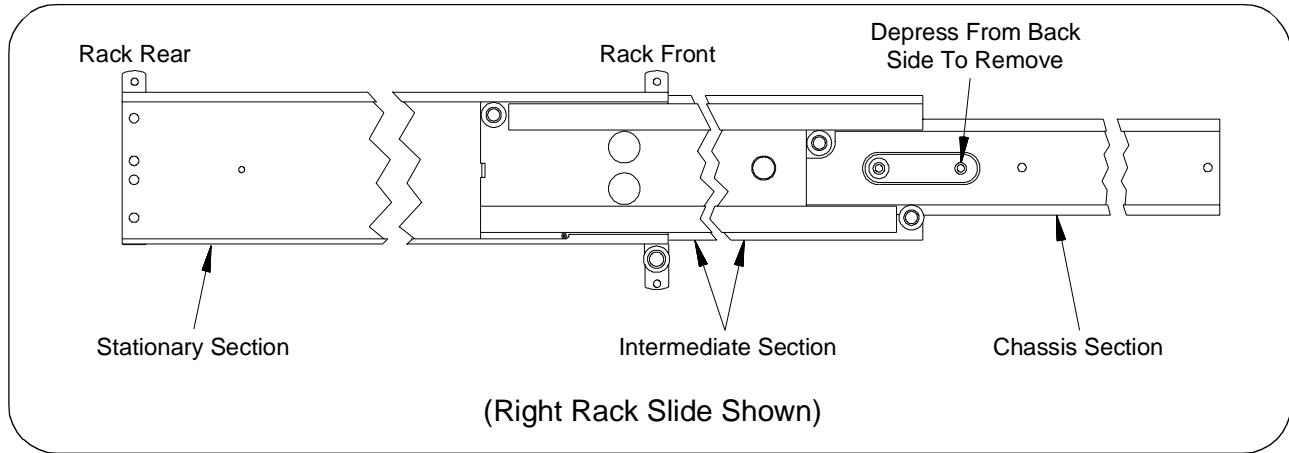

Figure 8 . Removing the Rack Slide Chassis Section from the Intermediate Section.

- Use two 10-32 x 0.5 flat head screws to attach the stationary section to the rack's front inside column through the channel nuts. Use two 10-32 x 0.5 pan-head screws to attach the stationary section to the rear inside column (see Figure 9). Repeat for the opposite side.

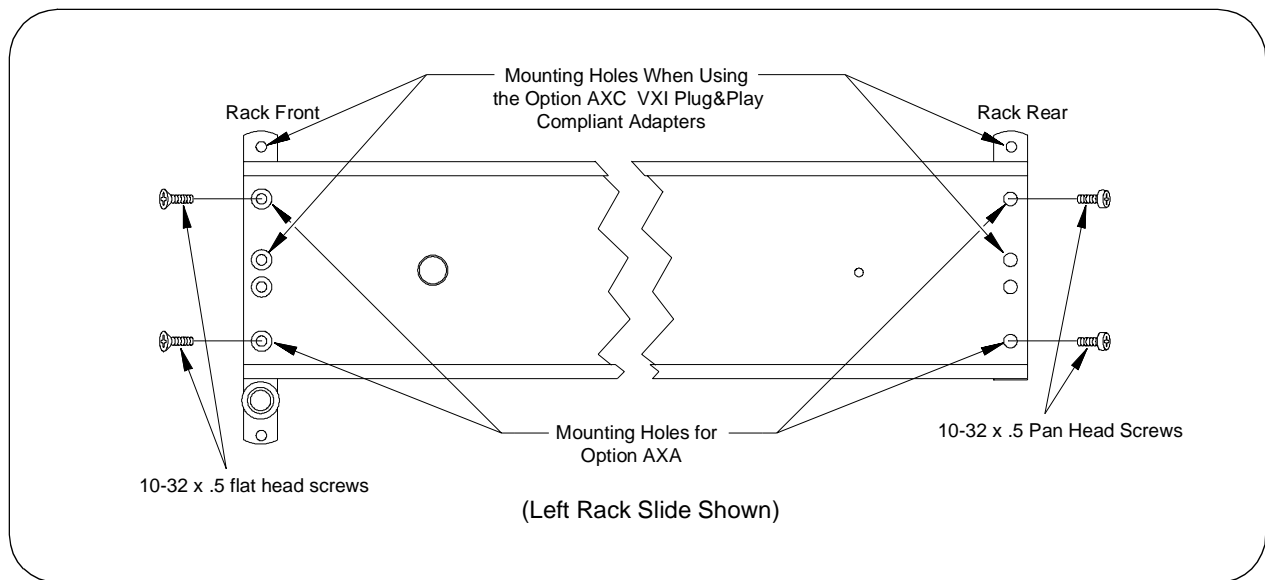

Figure 9 . Installing the Rack Slide Stationary Sections.

- Attach the rack mount adapters to the mainframe using the eight 10-32 x 0.312 pan head screws provided. To mount the mainframe flush with the rack front, begin with the 3rd hole from the front of the adapter (Figure 10).

The mainframe can be recess mounted up to 270.7 mm (10.6 inches) in approximately 12.3 mm (1/2 inch) increments. Use a minimum of three screws on each side.

8. Attach the chassis sections to the rack mount adapters using four 10-32 x 0.312 flat head screws per side (Figure 10). Note that in some recess positions, the front screw will not be used.

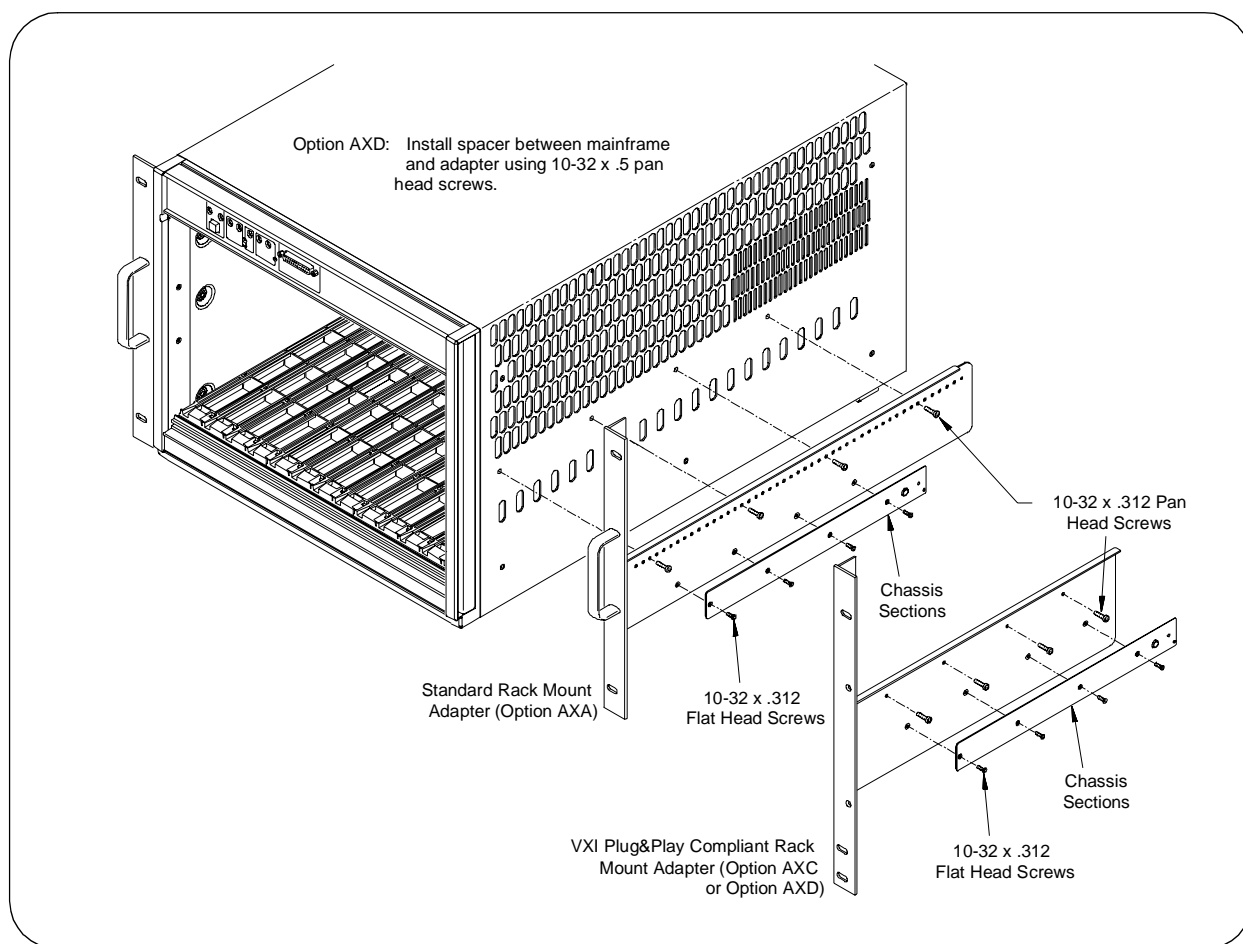

Figure 10 . Attaching the Rack Mount Adapters and Rack Slide Chassis Sections to the Mainframe.

9. If rack space under the mainframe is required for other instruments, remove the mainframe feet by lifting the tabs and sliding the feet towards the center of the mainframe.
10. Slide the intermediate sections out from the rack slide stationary sections until they lock into place. With one person on each side, lift the mainframe and slide the chassis sections into the intermediate sections until the chassis sections lock into place. Slide the mainframe into the rack until the rack mount adapter flanges are against the rack's vertical columns. Secure the mainframe to the rack using the adapter dress screws.

WARNING

To prevent injury during rack mounting, the mainframe should be empty and two people should lift the mainframe into the rack.

Rack Mounting the Agilent E840xA Using Rack Slides in a Non-Agilent Rack

This section describes how to rack mount the Agilent840x mainframes with the Option AXD Plug&Play Compliant Adapter Kit in a non-Agilent rack using rack slides (Agilent p/n 1494-0411) with end brackets (Agilent p/n 1494-0064). Refer to Figures 6-10, although in some cases mounting hole positions may be different.

1. Using the rack mount adapters as templates, position the adapters on the rack's vertical columns where the mainframe will be installed. Position the adapter to place the three rack ear holes directly over holes in the rack's vertical columns while the adapter flanges cover nine full EIA rack units with no overlap. Slide channel nuts over the rack holes to be used, behind the holes in the adapter flanges. This will be the 4th, 25th and 27th holes in the 9U space covered by the flanges, counting from the top.
2. Remove the rack slide chassis sections from the intermediate sections. (The chassis sections will later be attached to the rack mount adapters.) Slide the intermediate sections back into the stationary sections.
3. Attach the heavy duty end brackets to the slide stationary sections, front and rear. With the brackets centered on the slides, use the 2nd and 4th slots from the top, and corresponding holes in the slides. Use flat head screws in the front and pan head screws in the rear. Tighten the front screws, but leave the rear screws finger tight until the slides have been positioned in the rack.
4. Using the 15th and 18th hole down from the top of the 9U space, attach the slide stationary sections with end brackets to the rack's front column. Use the four flat head screws from the rack mount kit and nut bars from the bracket kit. (The tapped holes in the nut bars should be to the inside.) Attach the rear brackets on the stationary sections to the rack's rear columns using pan head screws and nut bars. Once in place, tighten the brackets to the slide.
5. Attach the slide chassis sections to the rack mount adapters using four M5x8 flat head screws per side. (Do not attach to mainframe at this point.) Slide the adapter assemblies into the slides mounted in the rack, and adjust the position of the slides in the rack so that the adapter flanges are spread apart as far as possible but still move into and out of the rack. (The distance between the outsides of the flanges should be 19.00"). When positioned, tighten the slide brackets to the rack's vertical columns. Be sure the slides are parallel by checking the attachments at the rear.

6. Remove the adapter assemblies from the slides, and mount them to the mainframe. Use four 10-32 x .375 pan head screws on the right side, and four 10-33 x .500 screws on the left side, with the spacer bar between the left adapter and the mainframe.

WARNING To prevent injury during rack mounting, the mainframe should be empty and two people should lift the mainframe into the rack.

7. Slide the rack slide intermediate sections out until they lock in place. With one person on each side, lift the mainframe and slide the chassis sections into the intermediate sections until the chassis sections lock into place. Slide the mainframe into the rack until the adapter flanges are against the rack's vertical columns.
8. Slide the unit back out and attach the receiver adapter plate, using four flat head screws through the flanges into the plate, following the manufacturer's instructions.

Installing the Cable Tray

The Agilent E840xA Cable Tray (E8400-60006) allows you to route VXI instrument cables and wires under the mainframe. The cable tray can be used when the mainframe is on a bench top or when mounted in a standard EIA cabinet. The tray is compatible with the support rail (Agilent E3664AC) and rack slide (Agilent p/n 1494-0411) kits.

Note If you ordered the support rail (Agilent E3664AC) or rack slide (p/n 1494-0411) kit, install the cable tray before rack mounting the mainframe.

Parts List The parts included in the cable tray kit are shown in Table 3.

Table 3. Agilent E8400A Cable Tray Kit Parts List.

Quantity	Description	Part Number
1	Cable Tray	E8400-04102
4	Cable Tray-to-Mainframe Screws - 10-32 x 0.312 pan head	2680-0129

Procedure

1. Remove the four mainframe feet by lifting the tabs and moving each foot towards the center of the mainframe.
2. Attach the cable tray to the mainframe as shown in Figure 11 using four 10-32 x 0.312 pan head screws. Select the tray holes based on the amount of cable clearance required.

The bottom mounting holes position the tray over one additional EIA rack unit (44.5 mm), the top holes position the tray over two EIA rack units, and the center holes position the tray between one and two EIA rack units.

Note If the mainframe is mounted extending out from the rack, install the cable tray with the notched end at the front of the mainframe.

3. If the mainframe will be placed on a bench top, attach the mainframe feet to the cable tray. If the mainframe is to be rack mounted, you can save rack space by leaving the feet off.

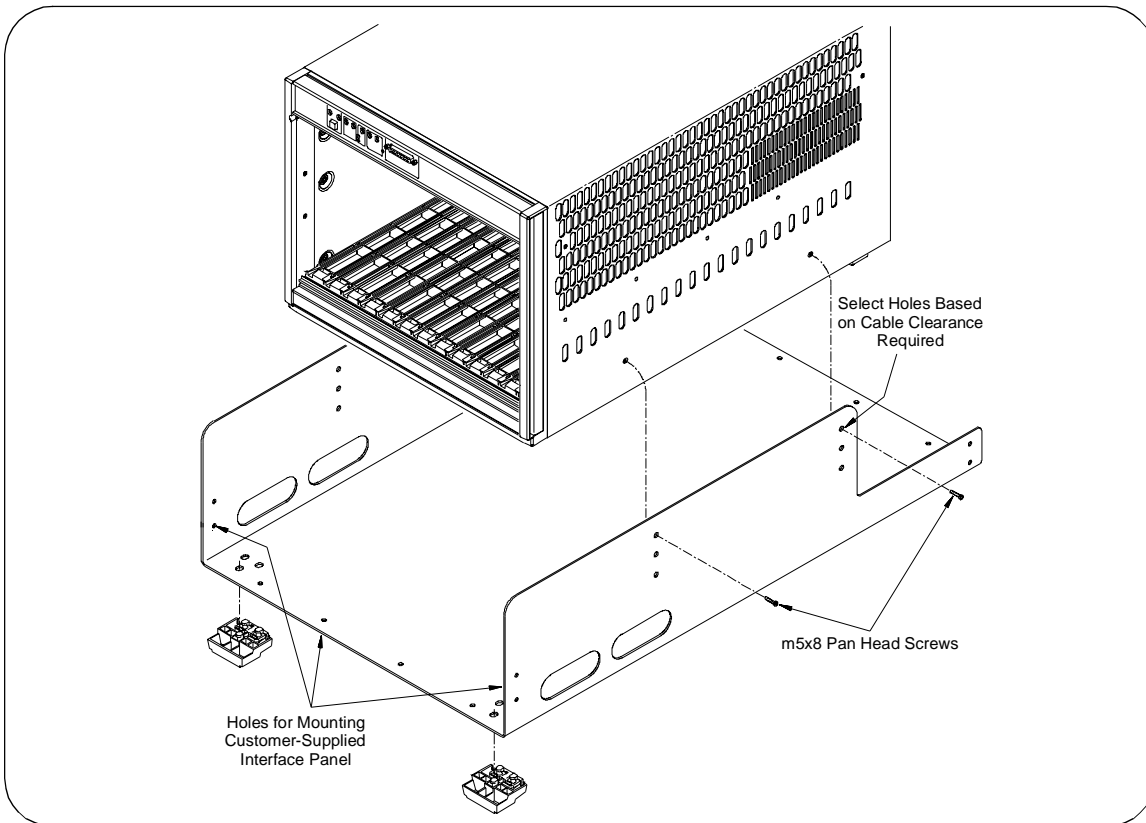

Figure 11 . Installing the Cable Tray.

Note Holes are provided at each end of the cable tray for mounting a customer-supplied interface panel. The maximum height of the panel must be 41.275 mm for a one EIA rack unit cable tray position, or 85.725 mm for a two EIA rack unit cable tray position. The panel width cannot exceed 424 mm. The four holes across the bottom are 101.6 mm center-to-center, and centered on the tray. The side holes are 34.9 mm center-to-center, with the bottom hole 25.4 mm above the tray's inside surface. All holes are 12.7 mm from the edge and have a diameter of 3.175 mm.



Manual Part Number: E8400-90038
Edition 3 E0309