

Keysight X-Series Signal Analyzers

This manual provides documentation for the following Analyzers:

PXA Signal Analyzer N9030A

Functional
Tests

Notices

© Keysight Technologies, Inc.
2006-2015

No part of this manual may be reproduced in any form or by any means (including electronic storage and retrieval or translation into a foreign language) without prior agreement and written consent from Keysight Technologies, Inc. as governed by United States and international copyright laws.

Trademark Acknowledgments

Manual Part Number

N9030-90018

Print Date

January 2015

Published in USA

Keysight Technologies
1400 Fountaingrove Parkway
Santa Rosa, CA 95403

Warranty

THE MATERIAL CONTAINED IN THIS DOCUMENT IS PROVIDED "AS IS," AND IS SUBJECT TO BEING CHANGED, WITHOUT NOTICE, IN FUTURE EDITIONS. FURTHER, TO THE MAXIMUM EXTENT PERMITTED BY APPLICABLE LAW, KEYSIGHT DISCLAIMS ALL WARRANTIES, EITHER EXPRESS OR IMPLIED WITH REGARD TO THIS MANUAL AND ANY INFORMATION CONTAINED HEREIN, INCLUDING BUT NOT LIMITED TO THE IMPLIED WARRANTIES OF MERCHANTABILITY AND FITNESS FOR A PARTICULAR PURPOSE. KEYSIGHT SHALL NOT BE LIABLE FOR ERRORS OR FOR INCIDENTAL OR CONSEQUENTIAL DAMAGES IN CONNECTION WITH THE FURNISHING, USE, OR PERFORMANCE OF THIS DOCUMENT OR ANY INFORMATION CONTAINED HEREIN. SHOULD KEYSIGHT AND THE USER HAVE A SEPARATE WRITTEN AGREEMENT WITH WARRANTY TERMS COVERING THE MATERIAL IN THIS DOCUMENT THAT CONFLICT WITH THESE TERMS, THE WARRANTY TERMS IN THE SEPARATE AGREEMENT WILL CONTROL.

Technology Licenses

The hardware and/or software described in this document are furnished under a license and may be used or copied only in accordance with the terms of such license.

Restricted Rights Legend

If software is for use in the performance of a U.S. Government prime contract or subcontract, Software is delivered and licensed as "Commercial computer software" as

defined in DFAR 252.227-7014 (June 1995), or as a "commercial item" as defined in FAR 2.101(a) or as "Restricted computer software" as defined in FAR 52.227-19 (June 1987) or any equivalent agency regulation or contract clause. Use, duplication or disclosure of Software is subject to Keysight Technologies' standard commercial license terms, and non-DOD Departments and Agencies of the U.S. Government will receive no greater than Restricted Rights as defined in FAR 52.227-19(c)(1-2) (June 1987). U.S. Government users will receive no greater than Limited Rights as defined in FAR 52.227-14 (June 1987) or DFAR 252.227-7015 (b)(2) (November 1995), as applicable in any technical data.

Safety Notices

CAUTION

A **CAUTION** notice denotes a hazard. It calls attention to an operating procedure, practice, or the like that, if not correctly performed or adhered to, could result in damage to the product or loss of important data. Do not proceed beyond a CAUTION notice until the indicated conditions are fully understood and met.

WARNING

A **WARNING** notice denotes a hazard. It calls attention to an operating procedure, practice, or the like that, if not correctly performed or adhered to, could result in personal injury or death. Do not proceed beyond a WARNING notice until the indicated conditions are fully understood and met.

Where to Find the Latest Information

Documentation is updated periodically. For the latest information about these products, including instrument software upgrades, application information, and product information, browse to one of the following URLs, according to the name of your product:

<http://www.keysight.com/find/pxa>

To receive the latest updates by email, subscribe to Keysight Email Updates at the following URL:

<http://www.keysight.com/find/MyKeysight>

Information on preventing analyzer damage can be found at:

www.keysight.com/find/PreventingInstrumentRepair

Is your product software up-to-date?

Periodically, Keysight releases software updates to fix known defects and incorporate product enhancements. To search for software updates for your product, go to the Keysight Technical Support website at:

<http://www.keysight.com/find/techsupport>

Table of Contents

- 1. **Functional Tests**
 - Functional Test Versus Performance Verification 4
 - Contents of this Document 5
 - Before Performing a Functional Test 6
 - Test Equipment 7
- 2. **Displayed Average Noise Level (DANL)**
 - Procedure 12
- 3. **Frequency Readout Accuracy**
 - Procedure 17
- 4. **Second Harmonic Distortion (SHD)**
 - Procedure 21
- 5. **Amplitude Accuracy at 50 MHz**
 - Procedure 25
 - Testing Preamp Option (P03, P08, P13, P26, P43, P44, P50) 27
- 6. **Frequency Response (Flatness)**
 - Procedure 31
- 7. **Frequency Response (Flatness), Preamp On**
 - Procedure 37
- 8. **Scale Fidelity**
 - Procedure 43
- 9. **BBIQ Input Frequency Response
(Option BBA only)**
 - Procedure 47

1 Functional Tests

Functional tests are tests of various instrument parameters that give a high degree of confidence that the analyzer is operating correctly. They are recommended as a check of analyzer operation for incoming inspection or after a repair. Measurement uncertainty analysis is not available for functional tests, and the analyzer is checked against limits that are wider than the published specifications. The functional tests are designed to test an analyzer operating within the temperature range defined by the analyzer specifications using a minimum set of test equipment. If a test does not pass, performance verification tests must be run to determine whether a problem exists.

Functional Test Versus Performance Verification

Functional tests use a minimum set of test equipment to check a much smaller range of parameters (and a limited number of data points for each parameter) than do performance verification tests. Functional tests use limits that are wider than the published specifications; measurement uncertainty analysis is **not** available for functional tests.

NOTE If a functional test does not pass, you must run performance verification tests to determine whether a problem exists.

Performance verification tests span a wide range of instrument parameters and provide the highest level of confidence that the instrument conforms to published specifications. These tests can be time consuming and require extensive test equipment.

Contents of this Document

This chapter includes the following:

- “**Before Performing a Functional Test**” on page 6 (what to do first).
- “**Test Equipment**” on page 7 (a list of the equipment required for **all** of the tests).

Subsequent chapters describe the following Functional Tests:

- “**Displayed Average Noise Level (DANL)**” on page 11
- “**Frequency Readout Accuracy**” on page 15
- “**Second Harmonic Distortion (SHD)**” on page 19
- “**Amplitude Accuracy at 50 MHz**” on page 23
- “**Frequency Response (Flatness)**” on page 29
- “**Frequency Response (Flatness), Preamp On**” on page 35
- “**Scale Fidelity**” on page 41

Each functional test includes:

- Test limits (pass/fail criteria)
- A description of the test
- The equipment required for the test
- A figure showing how to connect the equipment
- Step-by-step instructions
- One or more tables in which to record the measurement results

Before Performing a Functional Test

1. Ensure that you have the proper test equipment.
2. Switch on the unit under test (UUT) and let it warm up (in accordance with warm-up requirements in the instrument specifications).
3. Allow sufficient warm-up time for the required test equipment (refer to individual instrument documentation for warm-up specifications).
4. Ensure that the analyzer's frequency reference is set to Internal:
 - a. Press the **Input/Output**, **More**, **Freq Ref In** keys.
 - b. If the **Freq Ref In** softkey does **not** show Internal, press the **Freq Ref In** softkey and select Internal.
5. Following instrument warm-up, perform the auto align routine:
Press **System**, **Alignments**, **Align Now**, **All**.

NOTE

Functional test accuracy depends on the precision of the test equipment used. Ensure that all of the test equipment is calibrated before running a functional test.

Test Equipment

The table below summarizes the test equipment needed to perform all of the functional tests. Alternate equipment model numbers are given in case the recommended equipment is not available. If neither the recommended nor the alternative test equipment are available, substitute equipment that meets or exceeds the critical specifications listed.

Table 1-1

| Analyzer Option | Item | Critical Specifications | Recommended Keysight Model | Alternate Keysight Model |
|--------------------|---|--|----------------------------|--|
| Adapters | | | | |
| 503, 508, 513, 526 | 3.5 mm (f) to 3.5mm (f) (connector saver for source) | Frequency: 10 MHz to 26.5 GHz VSWR: < 1.1:1 | 83059B | 1250-1749 |
| 543, 544, 550 | 2.4 mm (f) to 2.4mm (f) (connector saver for source) | Frequency: 10 MHz to 50 GHz VSWR: < 1.1:1 | 11900B | |
| 543, 544, 550 | 2.4 mm (f) to 3.5mm (f) | Frequency: 10 MHz to 26.5 GHz VSWR: < 1.1:1 | 11901B | |
| All | BNC (f) to SMA (m) | Frequency: 40 MHz | 1250-1200 | |
| All | Type N (f) to Type N (f) | Frequency: 10 MHz to 18 GHz VSWR: < 1.05:1 | 1250-1472 | 1250-0777 |
| All | Type N (m) to 3.5 mm (m) | Frequency: 10 MHz to 18 GHz VSWR: < 1.1:1 | 1250-1743 | |
| All | Type N (m) to 3.5 mm (f) | Frequency: 10 MHz to 18 GHz VSWR: < 1.1:1 | 1250-1744 | |
| All | Type N (f) to 3.5 mm (f) | Frequency: 10 MHz to 18 GHz VSWR: < 1.1:1 | 1250-1745 | |
| All | Type N (m) to BNC (f) | Frequency: 10 MHz to 1 GHz VSWR: < 1.05:1 | 1250-1476 | |
| Attenuators | | | | |
| All | 10 dB Step Attenuator | Frequency: 50 MHz Range: 0 to 70 dB | 8495A | 8496A |
| All | 10 dB Fixed Attenuator (2 required) | Frequency: 50 MHz VSWR: < 1.2:1 | 8493C Option 010 | 8493A Option 010 or 8493B Option 010 |

Functional Tests
Test Equipment

Table 1-1

| Analyzer Option | Item | Critical Specifications | Recommended Keysight Model | Alternate Keysight Model |
|----------------------|------------------------------------|--|----------------------------|------------------------------|
| Preamp Options (Pxx) | 30 dB Fixed Attenuator | Accuracy: < 0.05 dB @ 50 MHz | 11708A | |
| Cables | | | | |
| All | 3.5 mm (1 meter) | Frequency: 10 MHz to 26.5 GHz VSWR: < 1.4:1 Loss: < 2.0 dB | 11500E | 8120-4921 |
| 543, 544, 550 | 2.4 mm (f) to 2.4 mm (m) (1 meter) | Frequency: 10 MHz to 50 GHz VSWR: < 1.55:1 at 50 GHz Loss: < 6.0 dB | 8120-6164 | |
| BBA | Cable, BNC | BNC male Length: 23 cm (9 in) max | 10502A | |
| All | Cable, BNC (3 required) | 120 cm (48 in.) BNC cable | 10503A | |
| Signal Source | | | | |
| All | Synthesized Sweeper | Frequency: 10 MHz to 50 GHz ^a Harmonic level: < -40 dBc Amplitude range: 10 to -20 dBm Frequency Accuracy: 0.02% | PSG ^b | 83630B, 83640B, 83650B |
| BBA | RF Signal Generator | Frequency: 250 kHz to 40 MHz Amplitude: ~-10 dBm Flatness: < ±0.75 dB | E4438C | 33250A |
| Power Meter | | | | |
| All | Power Meter | Power Reference Accuracy: ±1.2% Compatible with power sensor | E4418B | E4419B |
| All | Power Sensor | Frequency Range: 50 MHz to 3.66 GHz Amplitude Range: -70 to -20 dBm | 8481D | 8487D 8485D |
| 503, 508, 513 | Power Sensor | Frequency Range: 50 MHz to 13.66 GHz Amplitude Range: -30 to +20 dBm | 8481A | |
| 526 | Power Sensor | Frequency Range: 50 MHz to 26.5 GHz Amplitude Range: -30 to +20 dBm | 8485A | |
| 543, 544, 550 | Power Sensor | Frequency Range: 50 MHz to 50 GHz Amplitude Range: -30 to +20 dBm | 8487A | |
| P03 | Low Power Sensor | Frequency Range: 50 MHz to 3.6 GHz Amplitude Range: -70 to -20 dBm | 8481D | 8485D 8487D |

Functional Tests
Test Equipment

Table 1-1

| Analyzer Option | Item | Critical Specifications | Recommended Keysight Model | Alternate Keysight Model |
|--------------------------------|-------------------------|--|----------------------------|--------------------------|
| Preamp other than P03 | Low Power Sensor | Frequency Range: 50 MHz to 50 GHz ^c Amplitude Range: -70 to -20 dBm | 8487D | 8485D |
| Miscellaneous Equipment | | | | |
| All | Filter, 50 MHz Low Pass | Cutoff Frequency: 50 MHz Rejection at 65 MHz: > 40 dB Rejection at 75 MHz: > 60 dB Rejection at 80 MHz: > 60 dB Frequency: 10 MHz to 26.5 GHz | 0955-0306 | |
| 526 | Power Splitter, 3.5 mm | Nominal Insertion Loss: 6 dB Tracking Between Ports: < 0.25 dB | 11667B | |
| 543, 544, 550 | Power Splitter, 2.4 mm | Nominal Insertion Loss: 8.5 dB Tracking Between Ports: < 0.4 dB | 11667C | |
| 503, 508, 513 | Power Splitter | Nominal Insertion Loss: 6 dB Tracking Between Ports: < 0.25 dB | 11667A | 11667B |
| 503, 508, 513, 526 | Termination, 50Ω | Type N (m) Connector Frequency: 30 Hz to 26.5 GHz | 909A Option 012 | |
| 544, 545, 550 | Termination, 50Ω | 2.4 mm (f) Connector Frequency: 30 Hz to 50 GHz | 85138B | |
| BBA | Termination, 50Ω | Connector: BNC male Frequency: 250 kHz to 40 MHz | 11593A | |

- a. Maximum frequency equal to or greater than the maximum frequency of the PXA.
- b. PSG model numbers: E8244A, E8254A, E8247C Option 520, E8247C Option H31 or 540, E8257D Option 520, E8257D Option 550, E8257D Option 567, E8267D Option 544.
- c. Maximum frequency equal to or greater than the maximum frequency of the preamplifier option.

Functional Tests
Test Equipment

2 Displayed Average Noise Level (DANL)

Test Limits (with 0 dB input attenuation)

See [Table 2-1 on page 13](#) for values.

The Displayed Average Noise Level (DANL) of the signal analyzer is measured across a 10 kHz frequency span at several center frequencies. The analyzer input is terminated into a 50Ω load. A test is performed to assure the measurement is not performed in the presence of a residual response. The measurement is then averaged, and the result is normalized to a 1 Hz bandwidth.

| Item | Critical Specifications (for this test) | Recommended Keysight Model |
|--|---|----------------------------|
| Termination, 50Ω Type-N(m) ^a | Frequency: 10 MHz to 18 GHz | 909A Option 012 |
| Termination, 50Ω 2.4 mm (f) ^b | Frequency: 10 MHz to 50 GHz | 85138B |

a. for Options 503, 508, 513, and 526

b. for Options 543, 544, and 550

Figure 2-1 DANL Test Setup

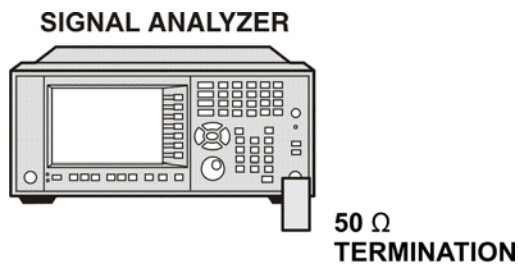

Mxa_ee82a

Procedure

1. Configure the equipment as shown in [Figure 2-1](#)
2. Press **Mode, Spectrum Analyzer, Mode Preset** on the analyzer.
3. Set up the signal analyzer by pressing:
 - FREQ Channel, Center Freq, 10, MHz**
 - Input/Output, RF Input, RF Coupling**, select **DC** (except Options 543, 544, and 550)
 - SPAN X Scale, Span, 10, kHz**
 - AMPTD Y Scale, -70, dBm**
 - AMPTD Y Scale, Attenuation, MechAtten, 0, dB**
 - BW, Res BW, 1, kHz**
 - BW, Video BW, 100, Hz**
 - Meas Setup, Average/Hold, Number, 20, Enter**
 - Trace/Detector, Trace Average**
 - Single**
4. Press **Restart**, then wait for Average/Hold to display 20/20.
5. Press **View/Display, Display**, then press **Display Line, On**.
6. Rotate the knob and set the display line at the average amplitude of the displayed noise floor by visual inspection.
7. Confirm that the measurement is performed on the analyzer noise floor and not on a residual response within the displayed 10 kHz span.

NOTE Ignore the residual response if one appears when taking the measurement.

8. Enter the value of the display line as the Measured Average Noise Level at 10 MHz column in [Table 2-1](#).
9. Normalize the measured value to a 1 Hz BW by adding 30 dB to the measured value.

NOTE The 30 dB value is added because the formula used to calculate the value of the noise power in a 1 Hz BW when measured with a 1 kHz BW is:

Normalized Noise = 10 Log (BW 2/BW 1) where BW 2 is the 1 kHz BW we measure and BW 1 is 1 Hz BW to which we want to normalize.

Therefore, 10 Log (1000) = 30 dB, so the noise floor will be 30 dB lower in a 1 Hz BW.

10. Enter the normalized value of the displayed average noise level in [Table 2-1](#).

Displayed Average Noise Level (DANL)
Procedure

11. The value of the normalized displayed average noise should be less than the specification value.
12. Change the analyzer center frequency to the next value listed in **Table 2-1**. Press: **FREQ Channel, Center Freq, [Table 2-1 Value], GHz**
13. Repeat **step 4** through **step 12** to fill in the remainder of **Table 2-1** for your analyzer frequency range.

Table 2-1 Displayed Average Noise Level (DANL) Results

| Center Frequency | Measured Average Noise Level (dBm) | Normalized Average Noise Level/(1 Hz BW) (dBm) | Test Limits (dBm) Options 503, 508, 513, 526 | Test Limits (dBm) Options 543, 544, 550 |
|------------------|------------------------------------|--|--|---|
| 10 MHz | | | -153 | -153 |
| 2 GHz | | | -152 | -152 |
| 6 GHz | | | -146 | -142 |
| 13 GHz | | | -147 | -145 |
| 20 GHz | | | -140 | -139 |
| 26.5 GHz | | | -135 | -137 |
| 30 GHz | | | N/A | -136 |
| 35 GHz | | | N/A | -131 |
| 40 GHz | | | N/A | -129 |
| 43.5 GHz | | | N/A | -126 |
| 50 GHz | | | N/A | -126 |

Displayed Average Noise Level (DANL)
Procedure

3 Frequency Readout Accuracy

Test Limits

Frequency Readout Accuracy is equivalent to the following equation:

$$\pm(0.25\% \times \text{span} + 5\% \times \text{RBW} + 2 \text{ Hz} + 0.5 \times \text{horizontal resolution})$$

See [Table 3-1 on page 17](#) for actual values.

The frequency readout accuracy is measured in several spans and center frequencies that allow both internal analyzer synthesizer modes and prefilter bandwidths to be tested. Frequency reference error is eliminated by using the same frequency standard for the analyzer and signal source.

| Item | Critical Specification (for this test) | Recommended Keysight Model |
|--|--|-------------------------------|
| Adapter, Type-N (m), to 3.5 mm (f) ^a | Frequency: 10 MHz to 1.51 GHz VSWR: < 1.1:1 | 1250-1744 |
| Adapter, 3.5 mm (f) to 3.5 mm (f) ^a | Frequency: 10 MHz to 1.51 GHz VSWR: < 1.1:1 | 83059B |
| Adapter, 2.4 mm (f) to 2.4 mm (f) ^b | Frequency: 10 MHz to 1.51 GHz VSWR: < 1.1:1 | 11900B |
| Cable, 2.4 mm, 1 meter ^b | Frequency: 10 MHz to 1.51 GHz VSWR: < 1.4:1 | 8120-6164 |
| Cable, 3.5 mm, 1 meter ^a | Frequency: 10 MHz to 1.51 GHz VSWR: < 1.4:1 | 11500E |
| Cable, BNC, 120 cm | Frequency: 10 MHz | 10503A |
| Synthesized Sweeper | Frequency: 10 MHz to 1.51 GHz | PSG |

a. for Options 503, 508, 513, 526

b. for Options 543, 544, 550

Figure 3-1

Frequency Readout Accuracy Test Setup

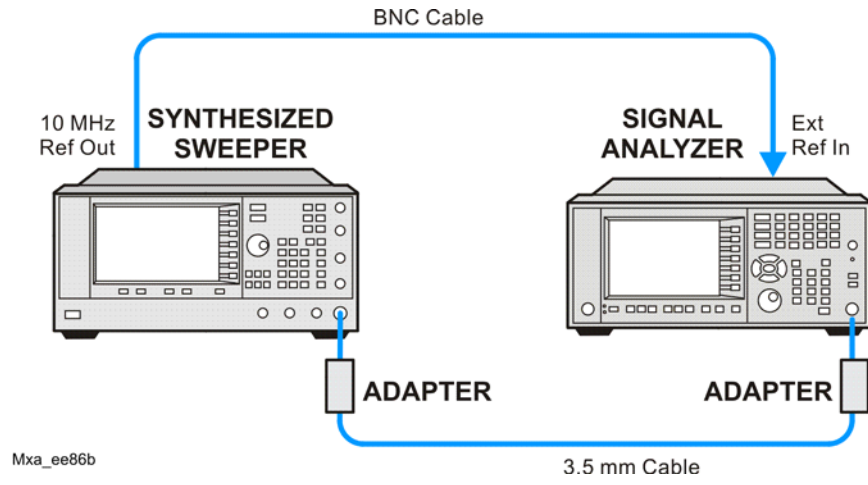

Procedure

1. Configure the equipment as shown in **Figure 3-1**. Confirm the analyzer's built-in auto alignment has been performed within the past 24 hours.
2. On the synthesized sweeper, press **PRESET**, then set the controls as follows:
 - FREQUENCY, 1505, MHz**
 - POWER LEVEL, -10, dBm**
 - RF, On**
3. Set up the signal analyzer by pressing:
 - Mode, Spectrum Analyzer**
 - Mode Preset**
 - Input/Output, More, Freq Ref In, External**
 - FREQ Channel, Center Freq, 1505, MHz**
 - SPAN X Scale, Span, 2990, MHz**
 - Trace/Detector, More, Detector, Sample**
 - Single**
4. Press **Restart**.

Press **Peak Search** on the analyzer. If the instrument is functioning correctly, the marker reading in the active function block will be between the values listed in **Table 3-1**. Record the marker value in the Marker Frequency Readout column in **Table 3-1**.
5. On the signal analyzer, change the span and center frequency as listed in **Table 3-1**.
6. Change the synthesized sweeper frequency to match the center frequency of the analyzer.
7. Repeat **step 4** through **step 6** until the Marker Frequency Readout column of **Table 3-1** is complete.

Table 3-1 Frequency Readout Accuracy Results

| Span (MHz) | Center Frequency (MHz) | Minimum | Marker Frequency Readout | Maximum |
|------------|------------------------|-----------------|--------------------------|-----------------|
| 2990 | 1505 | 1495.9 MHz | | 1514.1 MHz |
| 127.2 | 1505 | 1504.56 MHz | | 1505.44 MHz |
| 54.1 | 1505 | 1504.8122 MHz | | 1505.1878 MHz |
| 7.95 | 1505 | 1504.97240 MHz | | 1505.0276 MHz |
| 0.106 | 1505 | 1504.999630 MHz | | 1505.000370 MHz |
| 1.98 | 517.59 | 517.58316 MHz | | 517.59684 MHz |
| 1.98 | 832.50 | 832.49316 MHz | | 832.50684 MHz |

Frequency Readout Accuracy
Procedure

4 Second Harmonic Distortion (SHD)

Test Limits

| Applied Frequency | Mixer Level ^a | Distortion |
|-------------------|--------------------------|------------|
| 40 MHz | -15 dBm | < -60 dBc |

a. Mixer Level = Input Level - RF Attenuation

This test checks the second harmonic distortion of the signal analyzer by tuning to twice the input frequency and examining the level of the distortion product. A low pass filter is inserted between the source and the signal analyzer to prevent the source second harmonic from artificially raising the second harmonic product displayed on the analyzer.

| Item | Critical Specifications (for this test) | Recommended Keysight Model |
|--|---|-------------------------------|
| Adapter, Type-N (m) to BNC (f) | Frequency: 10 MHz to 80 MHz VSWR: < 1.05:1 | 1250-1476 |
| Adapter, BNC (f) to SMA (m) | Frequency: 40 to 80 MHz | 1250-1200 |
| Adapter, 3.5 mm (f) to 3.5 mm (f) ^a | Frequency: 10 MHz to 80 MHz VSWR: < 1.1:1 | 83059B |
| Adapter, 2.4 mm (f) to 3.5 mm (f) ^b | Frequency: 10 MHz to 80 MHz VSWR: < 1.1:1 | 11901B |
| Cable, BNC 120 cm (2 required) | Frequency: 10 to 40 MHz | 10503A |
| Filter, 50 MHz Low Pass | Cutoff Frequency: 50 MHz Rejection at 65 MHz: > 40 dB Rejection at 75 MHz: > 60 dB | 0955-0306 |
| Synthesized Sweeper | Frequency: 50 MHz Spectral Purity: Better than -30 dBc | PSG |

a. for Options 503, 508, 513, 526

b. for Options 543, 544, 550

Figure 4-1 Second Harmonic Distortion Test Setup

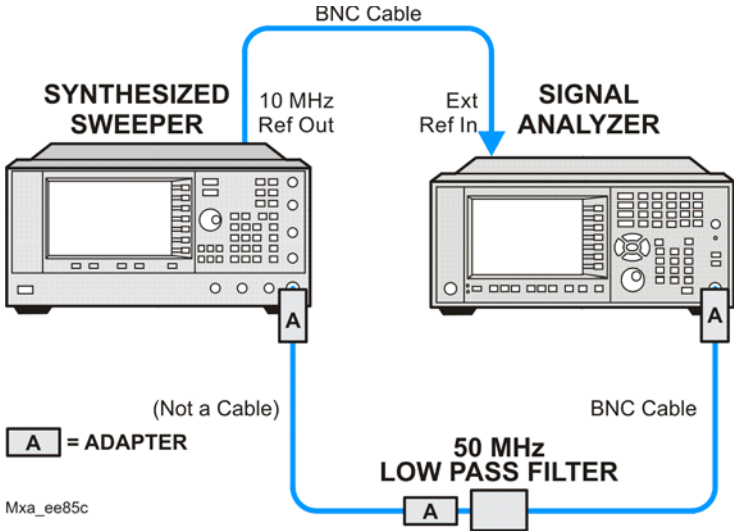

Procedure

1. Configure the equipment as shown in [Figure 4-1](#)
2. Press **Mode, Spectrum Analyzer, Mode Preset** on the signal analyzer and Preset the synthesized sweeper.
3. Set up the synthesized sweeper by pressing:
Frequency, 40, MHz
Amplitude, -5, dBm
4. Set up the signal analyzer by pressing:
Input/Output, More, Freq Ref In, External
FREQ Channel, Center Freq, 40, MHz
SPAN X Scale, Span, 1, MHz
AMPTD Y Scale, Attenuation, Mech Atten, 10, dB
5. On the analyzer, press **Peak Search**.
6. Adjust the synthesized sweeper amplitude for a signal analyzer display of $-5 \text{ dBm} \pm 0.1 \text{ dB}$.
7. On the signal analyzer, activate the marker delta function by pressing the **Marker** and **Delta** keys.
8. On the signal analyzer, press:
FREQ Channel, Center Freq, 80, MHz
Meas Setup, Average/Hold Number, 20, Enter
Trace/Detector, Trace Average
Single
9. Press **Peak Search**. Enter the displayed value under the Measured Second Harmonic Distortion (dBc) heading in [Table 4-1](#).

Table 4-1 Second Harmonic Distortion Results

| Applied Frequency (MHz) | Measured Second Harmonic Distortion (dBc) | Mixer Level (dBm) | Specification (dBc) |
|-------------------------|---|-------------------|---------------------|
| 40 | | -15 | -60 |

Second Harmonic Distortion (SHD)
Procedure

5 Amplitude Accuracy at 50 MHz

Test Limits

Amplitude Accuracy should remain within 1.13 dB of the measured source value across the range of source levels and changes in resolution bandwidth. The Preamp (option P03, P08, P13, P26, P43, P44, P50) should remain within ± 1.3 dB of measured values.

A synthesized sweeper is used as the signal source for the test. The source amplitude is varied using the signal source amplitude control. The attenuation and resolution bandwidth are varied on the signal analyzer. The source amplitude is measured by the power meter and signal analyzer at each setting, and the values compared. The difference between each pair of measurements indicates the amplitude accuracy.

| Item | Critical Specifications | Recommended Keysight Model |
|----------------------|---|----------------------------|
| Adapter ^a | Type-N (m), to 3.5 mm (m) | 1250-1743 |
| Adapter ^a | 3.5 mm (f) to 3.5 mm (f) | 83059B |
| Adapter ^b | 2.4 mm (f) to 3.5 mm (m) | 11901A |
| Adapter ^b | 2.4 mm (f) to 3.5 mm (f) | 11901B |
| Attenuator, 30 dB | Accuracy: < 0.5 dB at 50 MHz | 11708A |
| Cable | 3.5 mm, 1 meter | 11500E |
| Cable | BNC, 120 cm | 10503A |
| Power Meter | Compatible with power sensor | E4418B |
| Power Sensor | Amplitude Range: -25 dBm to 10 dBm | 8485A |
| Power Splitter | 3.5 mm (f) connectors 6 dB loss | 11667B |
| Synthesized Sweeper | Typical Temperature Stability: 0.01 dBc/°C | PSG |

a. for Options 503, 508, 513, 526

b. for Options 543, 544, 550

Figure 5-1 Amplitude Accuracy Test Setup

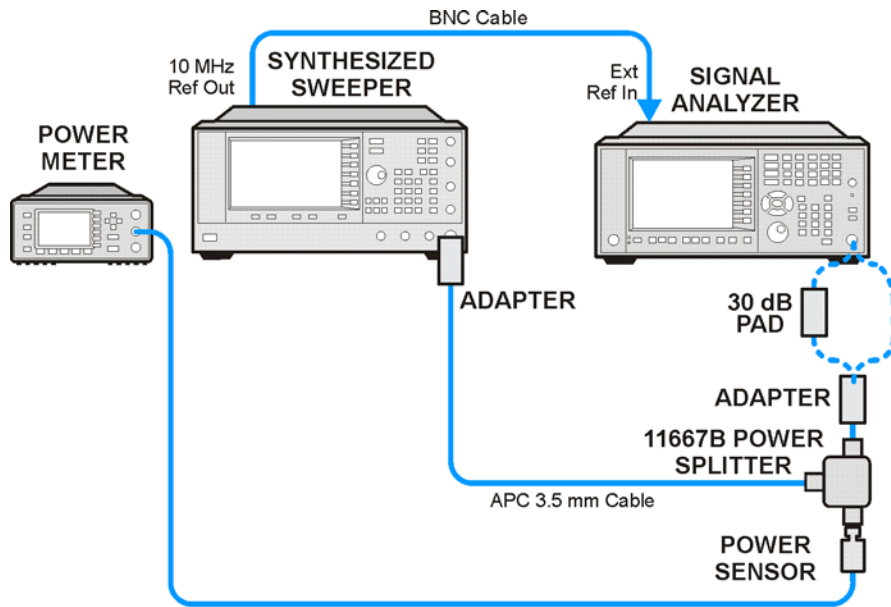

mx_a_ee181a

Procedure

1. Zero and calibrate the power meter.
2. Configure equipment as shown in [Figure 5-1](#), with the power splitter connected directly to the signal analyzer input through the adapter.

CAUTION

To minimize stress on the test equipment connections, support the power sensor.

3. If the auto alignment for the analyzer has not been performed within the past 24 hours, press **System, Alignments, Align Now, All** to perform the auto alignment routine.
4. Press **Mode, Spectrum Analyzer, Mode Preset** on the analyzer.
5. Set up the synthesized sweeper by pressing:
 - CW, 50, MHz**
 - Power Level, -4, dBm**
 - RF (On)**
6. Set up the signal analyzer by pressing:
 - Input/Output, More, Freq Ref In, External**
 - FREQ Channel, Center Freq, 50, MHz**
 - SPAN X Scale, 2, MHz**
 - AMPTD Y Scale, Attenuation, Mech Atten, 10, dB**
 - Input/Output, RF Input, RF Coupling, select DC (except Options 543, 544, 550)**
 - Sweep/Control, Sweep Setup, Swp Time Rules, SA - Accuracy**
 - Meas Setup, Average/Hold Number, 20, Enter**
 - Trace/Detector, Trace Average**
 - Single**
7. Perform the following steps for each row listed in [Table 5-1](#):
 - a. Set the synthesized sweeper amplitude to the value listed in the Nominal Source Amplitude column in [Table 5-1](#)
 - b. Set the Mech Atten as indicated in the Attenuation column in [Table 5-1](#)
 - c. Set the Span as listed in the Span column of [Table 5-1](#)
 - d. Record the synthesized sweeper amplitude, as measured by the power meter, in the Power Meter Amplitude column of [Table 5-1](#)
 - e. On the signal analyzer, press **Restart**.
 - f. Wait for the signal analyzer to finish averaging.
 - g. Press Peak Search.

Amplitude Accuracy at 50 MHz
Procedure

- h. Record the signal amplitude, as measured by the analyzer in the Measured Amplitude column of **Table 5-1**
- i. Calculate the signal amplitude accuracy error using the following equation, and record the results under the Amplitude Accuracy Error column:

$$\text{Amplitude Accuracy Error} = \text{Meas_amp} - \text{Power_meter}$$

Table 5-1 Amplitude Accuracy Results

| Nominal Source Amplitude (dBm) | Attenuation (dB) | Span (MHz) | Measured Amplitude Meas_amp (dBm) | Power Meter Amplitude Power_meter (dBm) | Amplitude Accuracy Error (dB) | Test Limit (dB) |
|--------------------------------|------------------|------------|-----------------------------------|---|-------------------------------|-----------------|
| -4 | 10 | 2 | | | | ±1.13 dB |
| -9 | 10 | 1 | | | | ±1.13 dB |
| -14 | 10 | 0.5 | | | | ±1.13 dB |
| -4 | 20 | 0.1 | | | | ±1.13 dB |
| -14 | 20 | 0.1 | | | | ±1.13 dB |
| -4 | 30 | 0.1 | | | | ±1.13 dB |
| -14 | 30 | 0.1 | | | | ±1.13 dB |

Testing Preamp Option (P03, P08, P13, P26, P43, P44, P50)

Instruments containing Options P03, P08, P13, P26, P43, P44, P50 must have the preamp function turned on and tested.

Procedure

1. On the analyzer, press **AMPTD Y Scale, More, Internal Preamp, Low Band**.
2. Connect the equipment as shown in [Figure 5-1 on page 24](#), using a 30 dB Pad between the adaptor and the signal analyzer input.
3. Set the synthesized sweeper amplitude to the value listed in the Nominal Source Amplitude column in [Table 5-2](#)
4. Set the signal analyzer input attenuation to 0 dB.
5. Set the Span as listed in [Table 5-2](#)
6. Record the synthesized sweeper amplitude, as measured by the power meter, in the Power Meter Amplitude column of [Table 5-2](#)
7. On the signal analyzer, press **Restart**.
8. Wait for the analyzer to finish averaging.
9. Press **Peak Search**.
10. Record the signal amplitude as measured by the analyzer in the measured amplitude column of [Table 5-2](#)
11. Calculate the signal amplitude accuracy using the following equation:

$$\text{Amplitude Accuracy Error} = \text{Meas_amp} + 30 \text{ dB} - \text{Power_meter}$$
12. Record the results under the Amplitude Accuracy Error column of [Table 5-2](#)

Table 5-2 Amplitude Accuracy Results (Option P03, P08, P13, P26, P43, P44, P50)

| Nominal Source Amplitude (dBm) | Low- band Preamp | Res BW (kHz) | Span (kHz) | Measured Amplitude Meas_amp (dBm) | Power Meter Amplitude Power_meter (dBm) | Amplitude Accuracy Error (dB) | Test Limit (dB) |
|--------------------------------|------------------|--------------|------------|-----------------------------------|---|-------------------------------|-----------------|
| -13 | ON | 1 | 106 | | | | ±1.30 dB |

Amplitude Accuracy at 50 MHz
Testing Preamp Option (P03, P08, P13, P26, P43, P44, P50)

6 Frequency Response (Flatness)

Test Limits

| Frequency Range | Limit Relative to 50 MHz |
|------------------------|--------------------------|
| 20 Hz to 3.6 GHz | ± 1.5 dB |
| > 3.6 GHz to 8.4 GHz | ± 2.5 dB |
| > 8.4 GHz to 13.6 GHz | ± 3.0 dB |
| > 13.6 GHz to 26.5 GHz | ± 3.5 dB |
| > 26.5 GHz to 34.5 GHz | ± 3.5 dB |
| > 34.5 GHz to 50 GHz | ± 4.2 dB |

The frequency response test measures the signal analyzer's amplitude error as a function of the tuned frequency. Measurements are made ranging from 50 MHz to the maximum frequency range of your analyzer. The signal source amplitude is measured with a power meter to eliminate error due to source flatness. The measured value is normalized to 50 MHz.

| Item | Critical Specifications (for this test) | Recommended Keysight Model |
|---|---|-------------------------------|
| Adapter, Type N (m) to 3.5 mm (m) ^a | Frequency: 10 MHz to 18 GHz VSWR: < 1.1:1 | 1250-1743 |
| Adapter, 3.5 mm (f) to 3.5 mm (f) ^a | Frequency: 10 MHz to 26.5 GHz VSWR: < 1.1:1 | 83059B |
| Cable, 3.5 mm, 1 meter ^a (Opt 503, 508, 513, 526) | Frequency: 10 MHz to 26.5 GHz VSWR: < 1.4:1 | 11500E |
| Cable, 2.4 mm, 1 meter ^b (Opt 543, 544, 550) | Frequency: 10 MHz to 50 GHz VSWR: < 1.55:1 | 8120-6164 |

Frequency Response (Flatness)

| Item | Critical Specifications (for this test) | Recommended Keysight Model |
|-----------------------------|--|-------------------------------|
| Cables, BNC 120 cm | Frequency: 10 MHz | 10503A |
| Power Meter | Compatible with power sensor | E4418B |
| Power Sensor | Frequency Range: 50 MHz to 26.5 GHz | 8485A |
| Power Sensor ^b | Frequency Range: 50 MHz to 50 GHz | 8487A |
| Power Splitter ^a | Frequency Range: 50 MHz to 26.5 GHz Tracking between ports: < 0.25 dB | 11667B |
| Power Splitter ^b | Frequency Range: 50 MHz to 50 GHz Tracking between ports: < 0.4 dB | 11667C |
| Synthesized Sweeper | Frequency Range: 50 MHz to maximum frequency of PXA | PSG |

a. for Options 503, 508, 513, 526

b. for Options 543, 544, 550

Figure 6-1 Frequency Response Test Setup

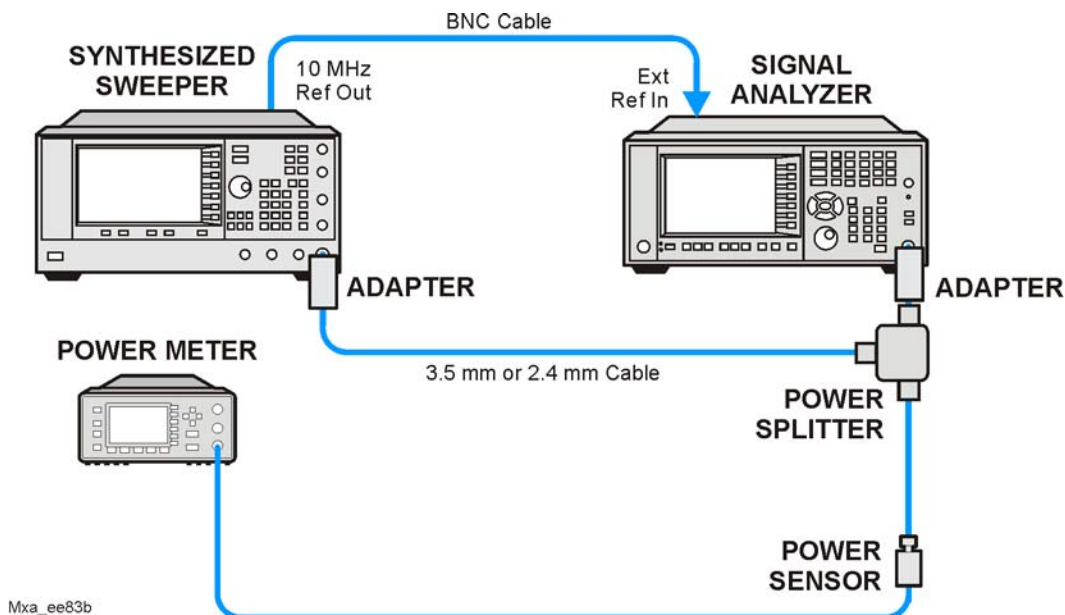

Procedure

1. Zero and calibrate the power meter and power sensor as described in the power meter operation manual.
2. Configure the equipment as shown in [Figure 6-1](#).

NOTE Connect the power splitter to the signal analyzer input using the appropriate adapter. Do not use a cable.

3. Assure the signal analyzer's built-in auto alignment has been performed within the last 24 hours.
4. Press **Mode, Spectrum Analyzer, Mode Preset** on the signal analyzer, and press **Preset** on the synthesized sweeper.
5. Set up the synthesized sweeper by pressing:
CW, 50, MHz
Power level, -4, dBm
6. Set up the signal analyzer by pressing:
Input/Output, More, Freq Ref In, External
FREQ Channel, Center Freq, 50, MHz
SPAN X Scale, Span, 50, kHz
AMPTD Y Scale, Ref Level, 0, dBm
7. Adjust the synthesized sweeper output power for a power meter reading of $-10 \text{ dBm} \pm 0.1 \text{ dB}$.
8. On the signal analyzer, press **Single**.
9. Press the **Peak Search** key on the signal analyzer to position the marker on the peak of the signal.
10. Refer to [Table 6-1, "Frequency Response \(Flatness\) Results."](#) Enter the amplitude of the signal displayed on the signal analyzer into the Meas_{Amp} column of [Table 6-1](#).
11. Enter the power meter reading into the $\text{Power}_{\text{Meter}}$ column of [Table 6-1](#).
12. Tune the synthesized sweeper and signal analyzer to the next frequency listed in [Table 6-1](#).
13. Enter the power sensor calibration factor into the power meter.
14. For frequencies 3.6 GHz and above, press **AMPTD Y Scale**, then **Presel Center** to center the preselector filter for an optimum amplitude measurement.
15. Repeat [step 7](#) through [step 14](#) and complete the remainder of [Table 6-1](#) for the frequency range of your analyzer.

Frequency Response (Flatness)
Procedure

16. Compute the measurement error ($\text{Meas}_{\text{Error}} = \text{Meas}_{\text{Amp}} - \text{Power}_{\text{Meter}}$).

17. Compute the flatness error normalized to 50 MHz:

$$(\text{Meas}_{\text{Error}} - \text{Meas}_{\text{Error @ 50 MHz}})$$

18. Enter the computed flatness error value into the Flat_{Norm} column of **Table 6-1**.

19. Compare the value of Flat_{Norm} to the test limit.

Table 6-1 Frequency Response (Flatness) Results

| Center Frequency | Analyzer Amplitude Meas _{amp} | Power Meter Measurement Power _{meter} | Meas Error Meas _{error} | Flatness Normalized to 50 MHz Flat _{Norm} | Flatness Error Test Limits (dB) |
|------------------|---|---|-------------------------------------|---|---------------------------------|
| 50 MHz | | | | 0 | Ref |
| 1 GHz | | | | | ±1.5 dB |
| 2 GHz | | | | | 1.5 dB |
| 3 GHz | | | | | ±1.5 dB |
| 3.5 GHz | | | | | ±1.5 dB |
| 4 GHz | | | | | ±2.5 dB |
| 6 GHz | | | | | ±2.5 dB |
| 8 GHz | | | | | ±2.5 dB |
| 9 GHz | | | | | ±3.0 dB |
| 11 GHz | | | | | ±3.0 dB |
| 13 GHz | | | | | ±3.0 dB |
| 14 GHz | | | | | ±3.5 dB |
| 17 GHz | | | | | ±3.5 dB |
| 20 GHz | | | | | ±3.5 dB |
| 23 GHz | | | | | ±3.5 dB |
| 26 GHz | | | | | ±3.5 dB |
| 29 GHz | | | | | ±3.5 dB |
| 32 GHz | | | | | ±3.5 dB |
| 35 GHz | | | | | ±4.2 dB |
| 38 GHz | | | | | ±4.2 dB |
| 41 GHz | | | | | ±4.2 dB |
| 42.5 GHz | | | | | ±4.2 dB |

Frequency Response (Flatness)
Procedure

Table 6-1 Frequency Response (Flatness) Results

| Center Frequency | Analyzer Amplitude $Meas_{amp}$ | Power Meter Measurement $Power_{meter}$ | Meas Error $Meas_{error}$ | Flatness Normalized to 50 MHz $Flat_{Norm}$ | Flatness Error Test Limits (dB) |
|------------------|------------------------------------|--|------------------------------|--|---------------------------------|
| 43.5 GHz | | | | | ± 4.2 dB |
| 46.5 GHz | | | | | ± 4.2 dB |
| 49.5 GHz | | | | | ± 4.2 dB |

Frequency Response (Flatness)
Procedure

7 Frequency Response (Flatness), Preamp On

Test Limits

| Frequency Range | Limit Relative to 50 MHz |
|------------------------|--------------------------|
| 100 kHz to 3.6 GHz | ±2.0 dB |
| > 3.6 GHz to 8.4 GHz | ±3.0 dB |
| > 8.4 GHz to 13.6 GHz | ±3.5 dB |
| > 13.6 GHz to 26.5 GHz | ±4.0 dB |
| > 26.5 GHz to 34.5 GHz | ±4.5 dB |
| > 34.5 GHz to 50 GHz | ±6.0 dB |

The frequency response test, with preamplifier on, measures the signal analyzer's amplitude error as a function of the tuned frequency. Measurements are made ranging from 50 MHz to the maximum frequency range of the preamp. The signal source amplitude is measured with a power meter to eliminate error due to source flatness. The measured value is normalized to 50 MHz.

| Item | Critical Specifications (for this test) | Recommended Keysight Model |
|--|--|-------------------------------|
| Adapter, Type N (m) to 3.5 mm (m) ^a | Frequency: 10 MHz to 18 GHz VSWR: < 1.1:1 | 1250-1743 |
| Adapter, 3.5 mm (f) to 3.5 mm (f) ^a | Frequency: 10 MHz to 26.5 GHz VSWR: < 1.1:1 | 83059B |
| Cable, 3.5 mm, 1 meter ^a | Frequency: 10 MHz to 26.5 GHz VSWR: < 1.4:1 | 11500E |

| Item | Critical Specifications (for this test) | Recommended Keysight Model |
|-------------------------------------|--|-------------------------------|
| Cable, 2.4 mm, 1 meter ^b | Frequency: 10 MHz to 50 GHz VSWR: < 1.55:1 | 8120-6164 |
| Cables, BNC 120 cm | Frequency: 10 MHz | 10503A |
| Power Meter | Compatible with power sensor | E4418B |
| Attenuator, 30 dB Fixed | Frequency: 50 MHz Accuracy: ± 0.05 dB | 11708A |
| Power Sensor ^a | Frequency Range: 50 MHz to 26.5 GHz Amplitude Range: -65 dBm to -55 dBm | 8485D |
| Power Sensor ^b | Frequency Range: 50 MHz to 50 GHz Amplitude Range: -65 dBm to -55 dBm | 8487D |
| Power Splitter ^a | Frequency Range: 50 MHz to 26.5 GHz Tracking between ports: < 0.25 dB | 11667B |
| Power Splitter ^b | Frequency Range: 50 MHz to 50 GHz Tracking between ports: < 0.4 dB | 11667C |
| Synthesized Sweeper | Frequency Range: 50 MHz to maximum frequency of the PXA | PSG |

- a. for Options P03, P08, P13, P26
- b. for Options P43, P44, P50

Figure 7-1 Frequency Response Test Setup

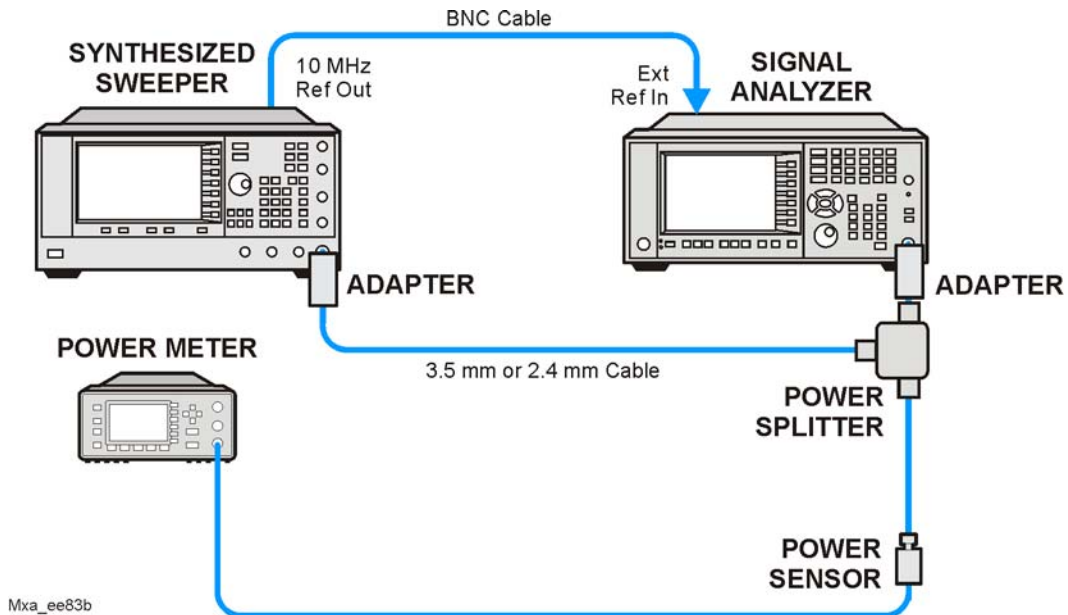

Procedure

1. Zero and calibrate the power meter and power sensor as described in the power meter operation manual.
2. Configure the equipment as shown in [Figure 7-1](#).

NOTE

Connect the power splitter to the signal analyzer input using the appropriate adapter. Do not use a cable.

3. Assure the signal analyzer's built-in auto alignment has been performed within the last 24 hours.
4. Press **Mode, Spectrum Analyzer, Mode Preset** on the signal analyzer, and press **Preset** on the synthesized sweeper.
5. Set up the synthesized sweeper by pressing:
CW, 50, MHz
Power level, -54, dBm
6. Set up the signal analyzer by pressing:
Input/Output, More, Freq Ref In, External
FREQ Channel, Center Freq, 50, MHz
SPAN X Scale, Span, 50, kHz
AMPTD Y Scale, More, Internal Preamp, Full Range
AMPTD Y Scale, Attenuation, Mech Atten, 0, dB
AMPTD Y Scale, Ref Level, -55, dBm
7. Adjust the synthesized sweeper output power for a power meter reading of $-60 \text{ dBm} \pm 0.1 \text{ dB}$.
8. On the signal analyzer, press **Single**.
9. Press the **Peak Search** key on the signal analyzer to position the marker on the peak of the signal.
10. Refer to [Table 7-1, "Frequency Response \(Flatness\) Results."](#) Enter the amplitude of the signal displayed on the signal analyzer into the Meas_{Amp} column of [Table 7-1](#).
11. Enter the power meter reading into the $\text{Power}_{\text{Meter}}$ column of [Table 7-1](#).
12. Tune the synthesized sweeper and signal analyzer to the next frequency listed in [Table 7-1](#).
13. Enter the power sensor calibration factor into the power meter.
14. For frequencies 3.6 GHz and above, press **AMPTD Y Scale**, then **Presel Center** to center the preselector filter for an optimum amplitude measurement.

Frequency Response (Flatness), Preamp On
Procedure

15. Repeat **step 7** through **step 14** and complete the remainder of **Table 7-1** for the frequency range of your preamp.

16. Compute the measurement error ($\text{Meas}_{\text{Error}} = \text{Meas}_{\text{Amp}} - \text{Power}_{\text{Meter}}$).

17. Compute the flatness error normalized to 50 MHz:

$$(\text{Meas}_{\text{Error}} - \text{Meas}_{\text{Error}} @ 50 \text{ MHz})$$

18. Enter the computed flatness error value into the $\text{Flat}_{\text{Norm}}$ column of **Table 7-1**.

19. Compare the value of $\text{Flat}_{\text{Norm}}$ to the test limit.

Table 7-1 Frequency Response (Flatness) Results

| Center Frequency | Analyzer Amplitude Meas_{amp} | Power Meter Measurement $\text{Power}_{\text{meter}}$ | Meas Error $\text{Meas}_{\text{error}}$ | Flatness Normalized to 50 MHz $\text{Flat}_{\text{Norm}}$ | Flatness Error Test Limits (dB) |
|------------------|--|--|--|--|---------------------------------|
| 50 MHz | | | | 0 | Ref |
| 1 GHz | | | | | ±2.0 dB |
| 2 GHz | | | | | ±2.0 dB |
| 3 GHz | | | | | ±2.0 dB |
| 3.5 GHz | | | | | ±2.0 dB |
| 4 GHz | | | | | ±3.0 dB |
| 6 GHz | | | | | ±3.0 dB |
| 8 GHz | | | | | ±3.0 dB |
| 9 GHz | | | | | ±3.5 dB |
| 11 GHz | | | | | ±3.5 dB |
| 13 GHz | | | | | ±3.5 dB |
| 14 GHz | | | | | ±4.0 dB |
| 17 GHz | | | | | ±4.0 dB |
| 20 GHz | | | | | ±4.0 dB |
| 23 GHz | | | | | ±4.0 dB |
| 26 GHz | | | | | ±4.0 dB |
| 29 GHz | | | | | ±4.0 dB |
| 32 GHz | | | | | ±4.0 dB |
| 35 GHz | | | | | ±5.0 dB |
| 38 GHz | | | | | ±5.0 dB |
| 41 GHz | | | | | ±5.0 dB |

Frequency Response (Flatness), Preamp On
Procedure

Table 7-1 Frequency Response (Flatness) Results

| Center Frequency | Analyzer Amplitude $Meas_{amp}$ | Power Meter Measurement $Power_{meter}$ | Meas Error $Meas_{error}$ | Flatness Normalized to 50 MHz $Flat_{Norm}$ | Flatness Error Test Limits (dB) |
|------------------|------------------------------------|--|------------------------------|--|---------------------------------|
| 42.5 GHz | | | | | ±5.0 dB |
| 43.5 GHz | | | | | ±5.0 dB |
| 46.5 GHz | | | | | ±5.0 dB |
| 49.5 GHz | | | | | ±5.0 dB |

Frequency Response (Flatness), Preamp On
Procedure

8 Scale Fidelity

Test Limits

The scale fidelity error will be $\leq \pm 1.0$ dB with ≤ -10 dBm at the mixer.

This test checks the scale fidelity of the instrument by maintaining a constant reference level and measuring signals of different amplitudes over most of the display range. This test sets the input attenuator to 10 dB and the Reference Level to 0 dBm. The external attenuator is set to 0 dB, and the amplitude of the source is adjusted to set the displayed signal at the reference level.

The instrument's internal marker is used to measure the reference amplitude. The Marker Delta function is activated and the RF input is reduced using the external precision step attenuator. Signal input levels from 0 dBm to -50 dBm are measured.

| Item | Critical Specifications (for this test) | Recommended Keysight Model |
|--|---|-------------------------------|
| Adapter, Type-N (m), to 3.5 mm (f) ^a | Frequency: 50 MHz VSWR: < 1.1:1 | 1250-1745 |
| Adapter, 3.5 mm (f) to 3.5 mm (f) ^a | Frequency: 50 MHz VSWR: < 1.1:1 | 83059B |
| Adapter, 2.4 mm (f) to 3.5 mm (f) (2 required) ^b | Frequency: 50 MHz VSWR: < 1.1:1 | 11901B |
| Attenuator, 10 dB Step | Range: 0-50 dB Frequency: 50 MHz Accuracy: ± 0.25 dB | 8495A |
| Attenuator, 10 dB fixed (2 required) | Frequency: 50 MHz VSWR: < 1.2:1 | 8493C, option 010 |
| Cable, 3.5 mm, 1 meter (2 required) | Frequency: 50 MHz VSWR: < 1.4:1 | 11500E |

| Item | Critical Specifications (for this test) | Recommended Keysight Model |
|---------------------|---|-------------------------------|
| Cable, BNC 120 cm | Frequency: 10 MHz | 10503A |
| Synthesized Sweeper | Output Level Accuracy: 0 to -15 dBm: ± 1.0 dB at 50 MHz | PSG |

a. for Options 503, 508, 513, 526

b. for Options 543, 544, 550

Figure 8-1 Scale Fidelity Setup

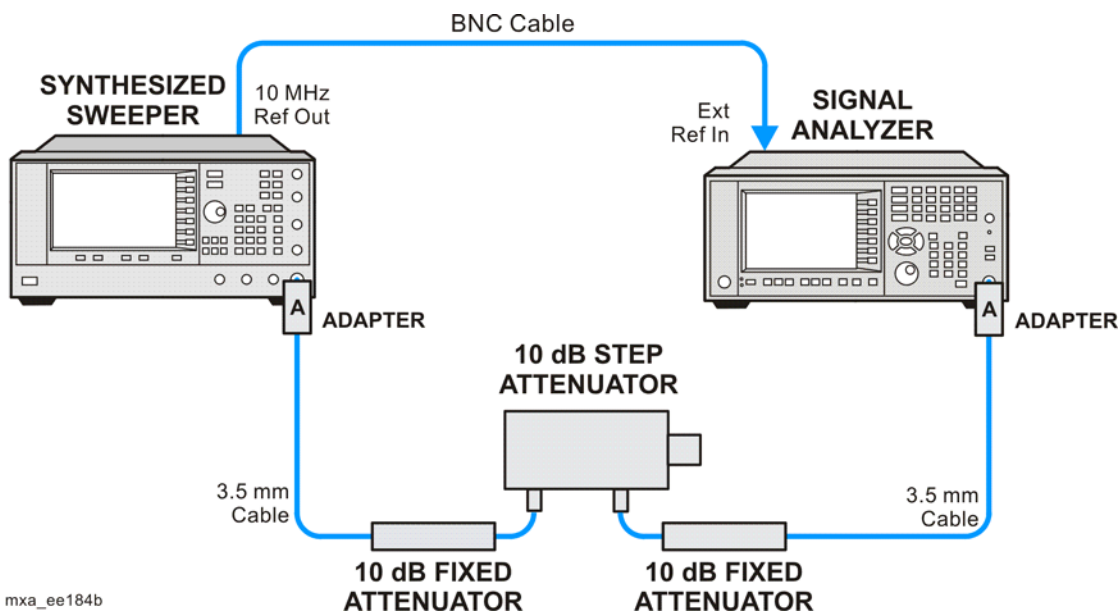

NOTE Averaging is used for all measurements to improve repeatability and reduce measurement uncertainty.

Procedure

1. Configure the equipment as shown in [Figure 8-1](#)
2. Preset the Source and press **Mode, Spectrum Analyzer, Mode Preset** on the analyzer.
3. Set up the synthesized sweeper by pressing:
 - Frequency, 50, MHz**
 - Amplitude, +5, dBm**
 - RF On/Off, On**
4. Set up the signal analyzer by pressing:
 - Input/Output, More, Freq Ref In, External**
 - FREQ Channel, Center Freq, 50, MHz**
 - SPAN X Scale, Span, 1, MHz**
 - AMPTD Y Scale, Ref Level, 0, dBm**
 - Meas Setup, Average/Hold Number, 10, Enter**
 - Trace/Detector, Trace Average**
 - Peak Search**
5. Set the external 10 dB step attenuator to 0 dB.
6. Adjust the amplitude on the signal source until the marker amplitude on the analyzer reads $-15 \text{ dBm} \pm 0.2 \text{ dB}$.
7. On the analyzer, press the **Single, Restart** to trigger a 10 sweep average.
8. On the analyzer, activate the Marker Delta function by pressing **Peak Search, Marker Delta**.
9. Perform the following steps for each attenuator setting listed in the table below:
 - a. Select the next External attenuator setting.
 - b. Press the **Restart** key to trigger a 10 sweep average.
 - c. Enter the delta marker value into [Table 8-1](#).
 - d. Check delta marker reading against the test limits.

Scale Fidelity
Procedure

Table 8-1 Scale Fidelity Results

| External Attenuator Setting | Minimum (dB) | Marker Delta Value (dB) | Maximum (dB) |
|------------------------------------|---------------------|--------------------------------|---------------------|
| 0 | N/A | Reference | N/A |
| 10 | 11.0 | | 9.0 |
| 20 | 21.0 | | 19.0 |
| 30 | 31.0 | | 29.0 |
| 40 | 41.0 | | 39.0 |
| 50 | 51.0 | | 49.0 |

9 BBIQ Input Frequency Response (Option BBA only)

Test Limits

| Frequency Range | Limit Relative to 250 kHz |
|---------------------------------------|---------------------------|
| Frequency Range | Limit Relative to 250 kHz |
| 250 kHz to 10 MHz (Standard) | ± 1.75 dB |
| 250 kHz to 25 MHz (Option B25) | ± 1.75 dB |
| 250 kHz to 40 MHz (Option S40 or SU1) | ± 1.75 dB |

This procedure tests the amplitude response of each of the BBIQ inputs versus frequency. For each input, a reference measurement is made at 250 kHz and then subsequent measurements are made at several frequencies up to the maximum IQ bandwidth. The amplitude difference between the measurement at 250 kHz and subsequent frequencies is calculated and compared to the test limit.

| Item | Critical Specifications | Recommended Keysight Model |
|---------------------|--|----------------------------|
| RF Signal Generator | Frequency: 250 kHz to 40 MHz Amplitude: ~ -10 dBm Flatness: $< \pm 0.75$ dB | E4438C |
| Cable, BNC | Connectors: BNC male Length: 23 cm (9 in) max | 10502A |
| Cable, BNC, 120 cm | Connectors: BNC male Frequency: 250 kHz to 40 MHz | 10503A |
| 50 Ohm Termination | Connector: BNC male Frequency: 250 kHz to 40 MHz | 11593A |

Figure 9-1 BBIQ Input Frequency Response Setup (I Input)

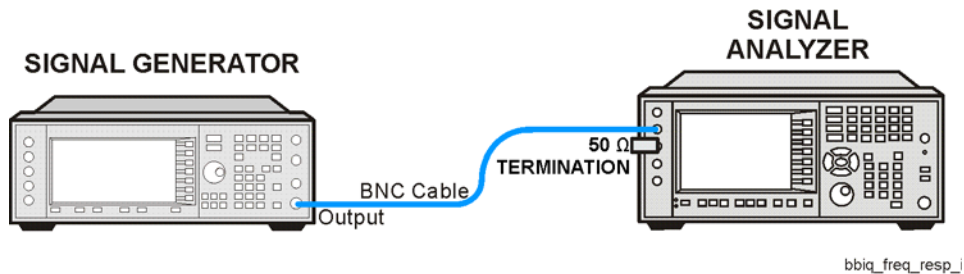

Figure 9-2 BBIQ Input Frequency Response Setup (I Input)

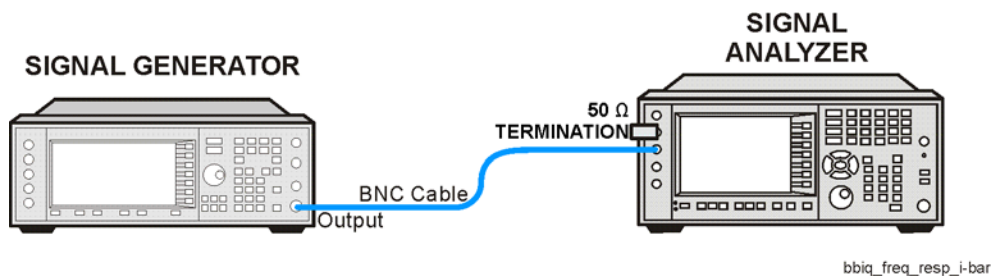

Figure 9-3 BBIQ Input Frequency Response Setup (Q Input)

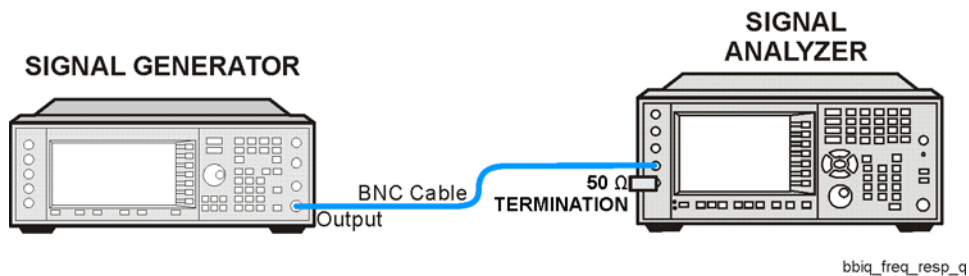
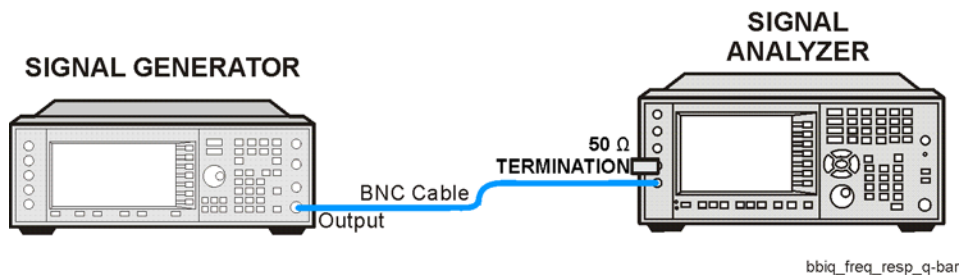

Figure 9-4 BBIQ Input Frequency Response Setup (Q Input)



Procedure

1. On the X-Series analyzer, press **Mode, IQ Analyzer (Basic)**. Press **Mode Preset**.
2. Press **Input/Output, I/Q** (to change to I/Q inputs), **I/Q** (to bring up the I/Q input menu), **I/Q Cable Calibrate**. Follow the instructions on screen. Use the short BNC cable listed above to perform the calibration. This process has several steps and will take about 3 minutes to perform.
3. Press **I/Q Path, I+jQ, I Setup, Differential (On)**. Press **Return, Q Setup, Q Same as I (Yes)**.
4. Preset the RF Signal Generator and set the controls as follows:

| | |
|-----------|---------|
| Frequency | 250 kHz |
| Amplitude | -10 dBm |
| RF | On |

NOTE

Once the RF Signal Generator's Amplitude is set, do not change the RF Signal Generator's Amplitude setting during the rest of this procedure.

5. Connect the longer BNC cable between the RF Signal Generator's RF OUTPUT and the I input of the X-Series analyzer, see [Figure 9-1](#)
6. Connect the 50 Ohm termination to the I input of the X-Series analyzer, see [Figure 9-1](#)
7. Press **Mode Preset** on the X-Series analyzer. Press **System, Show, System**. Note if either of the options listed below are present:

| |
|------------|
| N9030A-B25 |
| N9030A-S40 |
| N9030A-B40 |
8. If none of the options listed in [step 7](#) are present, the maximum IQ bandwidth is 10 MHz
9. If N9030A-B25 is present, but N9030A-S40 and N9030A-B40 are not present, the maximum IQ bandwidth is 25 MHz
10. If either N9030A-S40 or N9030A-B40 is present, the maximum IQ bandwidth is 40 MHz.
11. Press **FREQ** on the X-Series analyzer and set the Center Freq equal to one half the maximum IQ bandwidth determined above. For example, if the maximum IQ bandwidth is 40 MHz, set the Center Freq to 20 MHz.
12. Press **SPAN** on the X-Series analyzer and set the Span equal to the maximum IQ bandwidth determined above.
13. Press **BW** on the X-Series analyzer and set the Res BW to 100 kHz.

14. Press **Peak Search** on the X-Series analyzer. Record the marker amplitude reading in **Table 9-1** for the I Input at 250 kHz.

15. Set the RF Signal Generator to each of the remaining frequencies listed in **Table 9-1**, up to the maximum IQ bandwidth of the X-Series analyzer. At each frequency, do the following:

- a. Press **Peak Search**
- b. Record the marker amplitude reading in **Table 9-1** for the I Input at the current RF Signal Generator frequency

Table 9-1 BBIQ Input Frequency Response, I and I Inputs

| RF Signal Generator Frequency | I Input | | I Input | | Test Limits |
|---|------------------|--------------------|------------------|--------------------|-------------|
| | Marker Amplitude | Frequency Response | Marker Amplitude | Frequency Response | |
| 250 kHz | | 0.0 dB | | 0.0 dB | ±1.75 dB |
| 2 MHz | | | | | ±1.75 dB |
| 5 MHz | | | | | ±1.75 dB |
| 7.5 MHz | | | | | ±1.75 dB |
| 9.9 MHz | | | | | ±1.75 dB |
| Stop here if Maximum IQ Bandwidth is 10 MHz | | | | | |
| 12.5 MHz | | | | | ±1.75 dB |
| 15 MHz | | | | | ±1.75 dB |
| 17.5 MHz | | | | | ±1.75 dB |
| 20 MHz | | | | | ±1.75 dB |
| 22.5 MHz | | | | | ±1.75 dB |
| 24.9 MHz | | | | | ±1.75 dB |
| Stop here if Maximum IQ Bandwidth is 25 MHz | | | | | |
| 30 MHz | | | | | ±1.75 dB |
| 35 MHz | | | | | ±1.75 dB |
| 39.9 MHz | | | | | ±1.75 dB |

16. Set the RF Signal Generator frequency to 250 kHz

17. Connect the BNC Cable between the RF Signal Generator RF Output and the I input on the X-Series analyzer, see **Figure 9-2**

18. Connect the 50 Ohm termination to the I input on the X-Series analyzer, see **Figure 9-2**

19. Press **Peak Search** on the X-Series analyzer. Record the marker amplitude reading in **Table 9-1** for the I Input at 250 kHz.
20. Set the RF Signal Generator to each of the remaining frequencies listed in **Table 9-1**, up to the maximum IQ bandwidth of the X-Series analyzer. At each frequency, do the following:
 - a. Press **Peak Search**
 - b. Record the marker amplitude reading in **Table 9-1** for the I Input at the current RF Signal Generator frequency
21. Connect the BNC Cable between the RF Signal Generator RF Output and the Q input on the X-Series analyzer, see **Figure 9-3**
22. Connect the 50 Ohm termination to the Q input on the X-Series analyzer, see **Figure 9-3**
23. Set the RF Signal Generator frequency to 250 kHz.
24. Press **Peak Search** on the X-Series analyzer. Record the marker amplitude reading in **Table 9-2** for the Q Input at 250 kHz.
25. Set the RF Signal Generator to each of the remaining frequencies listed in **Table 9-2**, up to the maximum IQ bandwidth of the X-Series analyzer. At each frequency, do the following:

Press Peak Search

Record the marker amplitude reading in **Table 9-2** for the Q Input at the current RF Signal Generator frequency

Table 9-2 BBIQ Input Frequency Response, Q and Q Inputs

| RF Signal Generator Frequency | Q Input | | Q Input | | Test Limits |
|---|------------------|--------------------|------------------|--------------------|-------------|
| | Marker Amplitude | Frequency Response | Marker Amplitude | Frequency Response | |
| 250 kHz | | 0.0 dB | | 0.0 dB | ±1.75 dB |
| 2 MHz | | | | | ±1.75 dB |
| 5 MHz | | | | | ±1.75 dB |
| 7.5 MHz | | | | | ±1.75 dB |
| 9.9 MHz | | | | | ±1.75 dB |
| Stop here if Maximum IQ Band width is 10 MHz | | | | | |
| 12.5 MHz | | | | | ±1.75 dB |
| 15 MHz | | | | | ±1.75 dB |
| 17.5 MHz | | | | | ±1.75 dB |
| 20 MHz | | | | | ±1.75 dB |

Table 9-2 BBIQ Input Frequency Response, Q and Q Inputs

| RF Signal Generator Frequency | Q Input | | Q Input | | Test Limits |
|---|------------------|--------------------|------------------|--------------------|-------------|
| | Marker Amplitude | Frequency Response | Marker Amplitude | Frequency Response | |
| 22.5 MHz | | | | | ±1.75 dB |
| 24.9 MHz | | | | | ±1.75 dB |
| Stop here if Maximum IQ Band width is 25 MHz | | | | | |
| 30 MHz | | | | | ±1.75 dB |
| 35 MHz | | | | | ±1.75 dB |
| 39.9 MHz | | | | | ±1.75 dB |

26. Set the RF Signal Generator frequency to 250 kHz
27. Connect the BNC Cable between the RF Signal Generator RF Output and the Q input on the X-Series analyzer, see [Figure 9-4](#)
28. Connect the 50 Ohm termination to the Q input on the X-Series analyzer, see [Figure 9-4](#)
29. Press **Peak Search** on the X-Series analyzer. Record the marker amplitude reading in [Table 9-2](#) for the Q Input at 250 kHz.
30. Set the RF Signal Generator to each of the remaining frequencies listed in [Table 9-2](#), up to the maximum IQ bandwidth of the X-Series analyzer. At each frequency, do the following:
 - a. Press **Peak Search**
 - b. Record the marker amplitude reading in [Table 9-2](#) for the Q Input at the current RF Signal Generator frequency
31. In [Table 9-1](#) and [Table 9-2](#), calculate the Frequency Response for each input by subtracting the Marker Amplitude at 250 kHz for that input from the Marker Amplitude for each frequency greater than 250 kHz.

$$\text{Frequency Response} = \text{Marker Amplitude (Freq > 250 kHz)} - \text{Marker Amplitude (250 kHz)}$$

32. Compare the Frequency Response values to the Test Limits.

Index

A

amplitude accuracy test [23](#)
 option 1DS [27](#)
amplitude linearity test [41](#)

B

BBIQ frequency response [45](#)

D

DANL test [11](#)
displayed average noise level. See DANL [11](#)

E

equipment
 functional tests [7](#)
 warm-up time [6](#)

F

frequency readout accuracy test [15](#)
frequency response
 (flatness) test [29](#)
 BBIQ [45](#)
frequency response (flatness) test
 preamp on [35](#)
functional testing
 performance verification [4](#)
functional tests
 before performing [6](#)
 equipment list [7](#)
 introduction [3](#)
 vs performance verification tests [4](#)
 warm-up time [6](#)
 See also individual functional tests [3](#)

P

performance verification tests vs functional tests [4](#)

S

second harmonic distortion test [19](#)

T

tests. See functional tests



This information is subject to change without notice.
© Keysight Technologies, 2015
Published in USA, January 2015
N9030-90018
www.keysight.com