General

One receiver is required for each measurement or wavelength tracker axis.

The receiver converts the Doppler component of the laser beam from an interferometer or wavelength tracker into an electrical signal for the measurement electronics.

This chapter describes the following receivers:

- Agilent 10780C Receiver,
- Agilent 10780F Remote Receiver,
- Agilent E1708A Remote Dynamic Receiver, and
- Agilent E1709A Remote High-Performance Receiver

The Agilent 5519A and 5519B laser heads, which are a component of the Agilent 5529A/55292A Dynamic Calibrator system, has a built-in receiver. This chapter includes a brief description of that receiver. However, the installation and alignment of that receiver occurs as part of the Agilent 5519A/B Laser Head installation and alignment procedures, given in the *Agilent 5519A Laser Head Service Manual*.

Receiver specifications are given later in this chapter.

Comparison of Agilent Laser Receiver Families

Table 8-1 summarizes the features, characteristics, and specifications the Agilent 10780C/F, Agilent E1708A, and Agilent E1709A receivers.

The Agilent E1708A receiver is functionally similar to the Agilent 10780F receiver. However, the E1708A is not a direct replacement for 10780F. Comparisons of the two laser receiver families are provided in Table 8-1.

Comparison of Agilent Laser Receiver Families

Table 8-1. Comparison of Agilent Laser Receiver families

Characteristic	E1709A Receiver	E1708A Receiver	10780C, 10780F Receivers
Dynamic Range	25:1 to 6:1, depending on the AC/DC ratio	10:1	Not specified
Sensitivity	.20 -.80 μ W (depending on the AC/DC ratio), with 2 meter plastic cable	2.2 μ W (E1708A with 2-meter fiber optic cable) 5 μ W (E1708A with 10-meter fiber optic cable)	1.5 μ W (10780C) 2.2 μ W (10780F with 2-meter fiber optic cable) 5 μ W (10780F with 10-meter fiber optic cable)
Alignment Tolerance	For plastic fiber optic cable (Option 010) Roll: $\pm 3^\circ$ Pitch: $\pm 1^\circ$ Yaw: $\pm 1^\circ$ Agilent remote sensor is self-aligning with some interferometers.	For plastic fiber optic cable Roll: $\pm 3^\circ$ Pitch: $\pm 1^\circ$ Yaw: $\pm 1^\circ$ Agilent remote sensor is self-aligning with some interferometers.	Roll: $\pm 3^\circ$ Pitch: $\pm 1^\circ$ Yaw: $\pm 1^\circ$ 10780F is self-aligning with some interferometers.
Output Signal Frequency (Differential square wave at Doppler-shifted frequency)	100 kHz to 15.5 MHz (slew rates to 1 m/s with plane mirror optics)	100 kHz to 7.2 MHz (slew rate to 500 mm/s with plane mirror optics)	100 kHz to 7.2 MHz
Fixed Data Delay (typical)*	33.2 ns (typical) 0.01 ns/ $^\circ$ C	86 ns	Not specified
Errors due to frequency variations at fixed temperature*	For 25:1 to 6:1 input amplitude variations and frequency range of 100 kHz to 15.5 MHz $\leq \pm 1.2$ nm for linear optics $\leq \pm 0.6$ nm for plane mirror optics $\leq \pm 0.3$ nm for high resolution optics	For 3:1 input amplitude variations and frequency range of 100 kHz to 7.2 MHz $\leq \pm 1.2$ nm for linear optics $\leq \pm 0.6$ nm for plane mirror optics $\leq \pm 0.3$ nm for high resolution optics	Not specified
Signal Strength Monitor	0 to 10 volts output, proportional to optical input signal power	0 to 8 volts output, proportional to optical input signal power	Range: 0 to 0.8 volts
Power Requirements	15 Vdc ± 1 V at less than 267 mA	15 Vdc ± 1 V at less than 250 mA	+15 Vdc at 136 mA
Heat Dissipation	0.0 W for remote sensor 4.0 W typical for receiver	0.0 W for remote sensor 3.8 W typical for receiver	0.0 W for remote sensor 2.0 W typical for receiver
Temperature Range	0 to 40 $^\circ$ C operating	0 to 40 $^\circ$ C operating	0 to 40 $^\circ$ C operating

Comparison of Agilent Laser Receiver Families

Table 8-1. Comparison of Agilent Laser Receiver families (Continued)

Characteristic	E1709A Receiver	E1708A Receiver	10780C, 10780F Receivers
Fiber-Optic Cable Length	Option 010: 2m (plastic) Contact Agilent for longer fiber optic cables.	2 m standard (plastic) Contact Agilent for longer fiber optic cables.	2 m standard 10 m maximum
Weight	Receiver body:190 g Option 010: Remote sensor with 2 m cable: 26 g	Receiver body:170 g, Remote sensor with 2 m cable: 26 g	136 g, 10780C 126 g, 10780F body 26 g, remote sensor with 2 m cable
Dimensions	Height: 78.1 mm (3.075 in) Width: 115.6 mm (4.552 in) Depth: 19.8 mm (0.780 in)	Height: 78.1 mm (3.075 in) Width: 115.6 mm (4.552 in) Depth: 19.8 mm (0.780 in)	Height: 38.1 mm (1.50 in) Width: 114.8 mm (4.52 in) Depth: 19.8 mm (0.78 in)
Dimensions (receiver body, mounting area)	4 holes at corners of a rectangle 40.0 mm (1.575 in) high 108.0 mm (4.250 in) wide, centered on receiver body centerline	4 holes at corners of a rectangle 40.0 mm (1.575 in) high 108.0 mm (4.250 in) wide, centered on receiver body centerline	2 holes 107.8 mm (4.25 in) apart on receiver centerline
* For ac input signal power: E1708A: <200 μ W E1709A: <50 μ W			

Agilent 10780C and Agilent 10780F Receivers

Description

General

The Agilent 10780C Receiver or Agilent 10780F Remote Receiver converts the Doppler-shifted laser light from an interferometer or the wavelength tracker into electrical signals that can be processed by the rest of the laser system.

Lens and polarizer

Light enters either receiver through a lens and polarizer.

The Agilent 10780C lens and polarizer are built into the same assembly that houses the receiver electronics. Agilent 10780C Receiver's lens focuses the laser light onto a silicon PIN photodiode. Between the lens and the diode is a small piece of polarizing material oriented at 45° to the horizontal and vertical axes of the receiver.

The Agilent 10780 Remote Receiver's lens and polarizer are contained in a small assembly that is connected to the electronics housing by a fiber optic cable. The fiber optic cable allows the receiver module to be mounted away from the measurement area, removing a source of heat. The interference signal between the f1 and f2 polarizations is sent through the fiber optic cable to the electronics housing. The Agilent 10780F receiver's fiber optic sensor head may be mounted directly to certain interferometers (Agilent 10719A, Agilent 10721A, Agilent 10735A, Agilent 10736A).

Alignment pins are provided for easy installation and alignment. This eliminates the need for any other user-supplied mount for the sensor head.

When the receiver input is oriented properly, that is, with its vertical axis parallel or perpendicular to the axes of the laser head, the polarizer passes one-half the incident power from each of the two incoming orthogonally polarized components of the received laser beam.

Agilent 10780C and Agilent 10780F Receivers

Photodiode

The output from the polarizer assembly is an amplitude-modulated sine wave that is sent to a photodiode chip in the receiver's electronic housing. The frequency is the Doppler-shifted split frequency. The amplitude is proportional to the product of the incident powers of the two orthogonal components.

The photodiode generates an ac current, which is converted to an ac voltage at a frequency of 100 kHz to 6.0 MHz.

The detected signal voltage goes through an impedance transformation stage, two gain stages, and a level translation stage. The result, a TTL-level signal, goes to a TTL differential line driver, which is ac-coupled to the rest of the measurement electronics by a shielded twisted-pair cable.

The output is a differential square wave at the Doppler-shifted split frequency.

An available dc voltage output on the Agilent 10780C or Agilent 10780F receiver indicates incoming laser beam intensity.

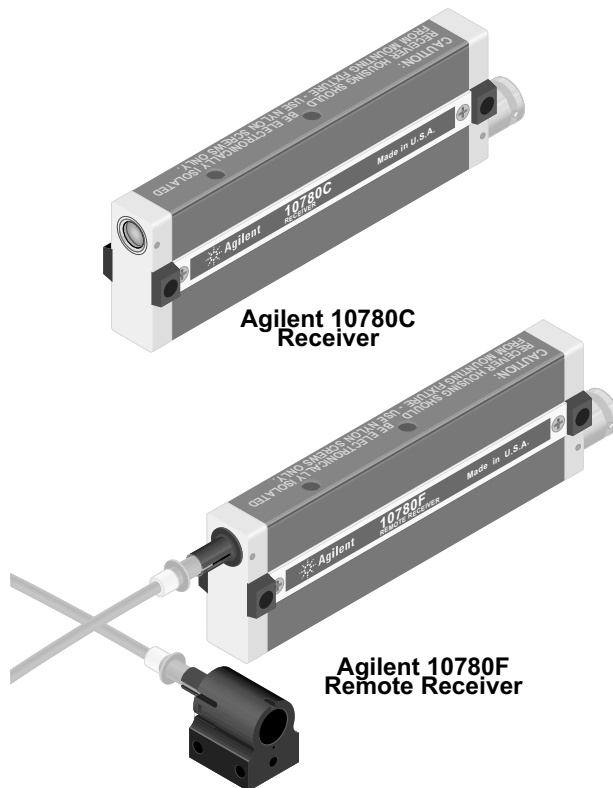

Figure 8-1. Agilent 10780C Receiver and Agilent 10780F Remote Receiver

Agilent 5519A/B Laser Head Receiver

The Agilent 5519A/B internal measurement receiver amplifies and converts the difference frequency of the laser beam (returned by the system optics) to TTL levels and supplies the signal to the measurement electronics.

During the measurement, the vertical and horizontal components pass through the turret and measurement optics and return to the measurement receiver. The difference between their frequencies will change whenever the measurement optics are moving.

The laser light returning from the measurement optics is directed through a polarizer and onto a photodiode. Because of the polarizer orientation, the beam power past the polarizer varies sinusoidally at the difference frequency of the two laser frequency components.

The beam power at the difference frequency is converted to TTL levels. The frequency of the TTL output is the measurement frequency.

Special considerations

Cables

General

Each Agilent 10780C or Agilent 10780F receiver requires a cable to carry signals and power between it and the measurement electronics axis board with which it is to be used. One cable is required per measurement axis. The cable used depends on the axis board used, and the cable length required.

Cables are described in Chapter 9, “Accessories,” of this manual.

The Agilent 5519A/B Laser Head receiver connection is made via the cable that also provides power for the laser. The cable depends on the axis board used. Cables are described in Chapter 9, “Accessories,” of this manual.

Agilent 10790A/B/C cables

An Agilent 10790A, Agilent 10790B, or Agilent 10790C Receiver Cable is used to connect the Agilent 10780C or Agilent 10780F receiver to the Agilent 10895A VME Axis Board, for both measurement and Wavelength Tracker axes.

Agilent 10780C and Agilent 10780F Receivers

Agilent 10880A/B/C cables

An Agilent 10880A, Agilent 10880B, or Agilent 10880C Receiver Cable is used to connect an Agilent 10780C or Agilent 10780F receiver to an Agilent 10885A PC Axis Board, Agilent 10889B PC Servo Axis Board, Agilent 10896B VME Laser Compensation Board, Agilent 10897B VME High Resolution Laser Axis Board, Agilent 10898A VME High Resolution Dual Laser Axis Board, or Agilent N1231A PCI Three-Axis Board, for both measurement and Wavelength Tracker axes.

Effects of motion and orientation

Motion of the receiver or laser head along the beam path (X) has no effect on the measurement, since both f_1 and f_2 would exhibit Doppler shift.

Small motions of the laser head, receiver, interferometer, or retroreflector in a direction perpendicular to the beam path (Y or Z) have no effect on the measurement. The only restriction is that sufficient light returns to the receiver.

Although the Laser Head or the Receiver may be rotated in 90° increments about the beam axis (roll), other roll deviations from the four optimum positions degrade the measurement signal. If either the Laser Head or Receiver is rotated 45° about the beam axis, all position information will be lost because the receiver will not be able to distinguish between the two frequencies.

Angular motion of the receiver about the Y axis, the Z axis, or both, has no effect on the measurement, within certain alignment limits.

Mounting

Offset aperture

Offset aperture allows flexibility in mounting the Agilent 10780C or Agilent 10780F receiver (that is, the bulk of the receiver or sensor head can be mounted above, below, right, or left of the incoming laser beam).

Agilent 10780F Remote Receiver sensor head

The Agilent 10780F receiver's fiber optic sensor head may be mounted directly to certain interferometers (Agilent 10719A, Agilent 10721A, Agilent 10735A, Agilent 10736A). Alignment pins are provided for easy installation and alignment. This eliminates the need for any other user-supplied mount for the sensor head.

Installation

When installing the receiver, keep the following points in mind:

- At a 45° position (roll), the signal will go to zero.
- Plastic mounting hardware electrically isolates the Agilent 10780C or Agilent 10780F receiver from the machine and reduces problems with heat conduction.
- The receiver typically dissipates 2.0 watts, with a maximum dissipation of 2.7 watts. Plastic pads keep an air gap around the receiver and act as thermal and electrical isolators.

CAUTION

Use Nylon screws only (Agilent 2360-0369). The receiver housing must be electrically isolated from the mounting fixture.

- The remote sensor in the Agilent 10780F Remote Receiver does not dissipate any power. The remote sensor does not require a nylon screw.
- Allow a 5 cm space at the rear of each receiver housing for each cable connection.
- Maintain a bend radius of at least 35 mm (1.4 inches) to prevent signal attenuation in the Agilent 10780F receiver's fiber optic cable.

Cable connection

Agilent 10790A/B/C Receiver Cable

This cable's connectors are identical on either end as shown in Figure 9-6. The connectors on the cable and on the receiver and Agilent 10895A axis board are "keyed" to go together only one way. The connectors on the cable each have a locking ring, which takes a 1/4-turn clockwise to secure the cable to its mating connector.

CAUTION

Each connector on an Agilent 10790A, Agilent 10790B, or Agilent 10790C cable has both a male and female half. Before making a connection, be sure the male half of the cable connector is properly aligned with the female half of the mating connector. Failure to align the pins prior to mating the connectors may result in damaged pins.

Agilent 10880A/B/C Receiver Cable

The connectors at each end are different as shown in Figure 9-7.

One connector is a bayonet connector that inserts into the Agilent 10885A, 10889B, 10896B, 10897B, 10898A, or N1231A axis board. The connectors lock together. To unlock the connectors, slide the cable connector sleeve away from the Agilent axis board's panel until the connectors separate.

CAUTION

Any attempt to twist the cable connector when it is connected to the Agilent 10885A panel connector may cause damage.

The other connector fits the connector on the receiver; this connector is "keyed" to go together only one way. This connector has a locking ring, which takes a 1/4-turn clockwise to secure the cable to its mating connector on the receiver.

Fasteners

The supplied nylon screws must be used to assure that the receiver housing is electrically isolated from the mounting fixture.

Clearance for laser beam

Figure 8-2 shows: 1) the clearance requirement for the laser beam passing the receiver or sensor head on its way to the interferometer or wavelength tracker, and 2) how the receiver alignment target can be used to be sure the receiver is positioned correctly with respect to this beam. Laser beam clearance is also shown in the receiver specification drawings at the end of this chapter.

RECEIVER BEAM CLEARANCES AND ALIGNMENT TARGETS

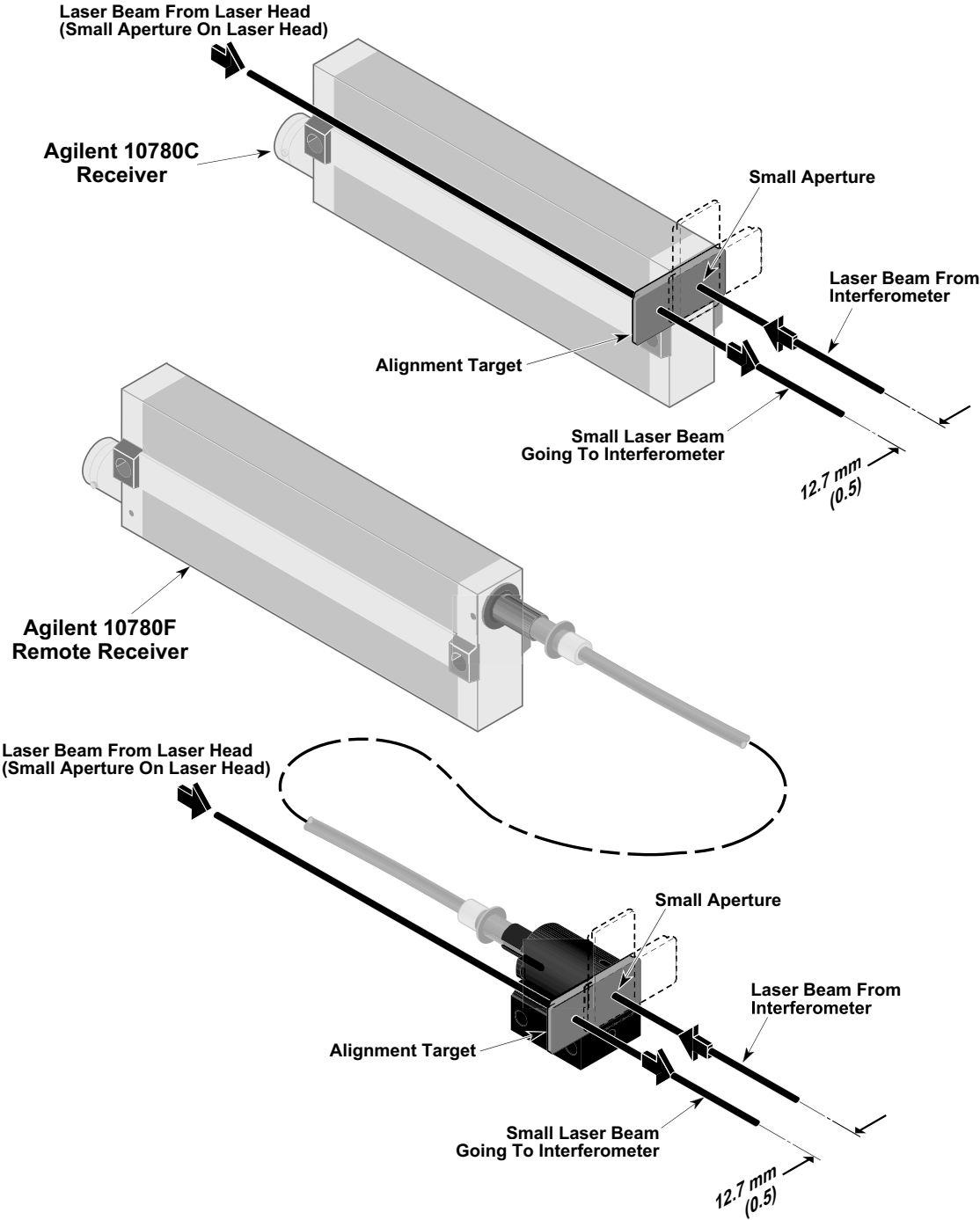

Figure 8-2. Agilent 10780C and Agilent 10780F Receiver beam clearances and alignment targets

Alignment

General

Each Agilent 10780C or Agilent 10780F Receiver in the measurement system requires an alignment relative to its input beam to maximize its measurement signal strength.

This alignment is typically done by positioning the receiver so the two polarization vectors from the laser head are parallel or perpendicular to the plane defined by the centerlines of the two mounting holes (within $\pm 3^\circ$).

Also, the beams should be centered on the receiver's input lens.

Alignment target

The Agilent 10780C or Agilent 10780F receiver is supplied with a snap-on beam target to ease coarse alignment. The alignment targets are shown in Figure 9-14 of Chapter 9, "Accessories," in this manual.

The alignment target attaches at the receiver lens and helps align the receiver to the center of the incident beam. It is also used to adjust the spacing between the beam going to the interferometer and the return beam incident on the receiver.

The Agilent Part Number for the standard Alignment Target for the Agilent 10780C Receiver is 10780-40003.

The alignment target for use with an Agilent 10780F Remote Receiver having a 9 mm lens is Agilent Part Number 10780-40009.

Principle

The receiver is aligned by moving it and rotating it relative to the beam axis.

Receiver alignment is performed during the optical system alignment. The receiver is moved to center the incident beam on its input lens.

The receiver photodetector only measures the overlapping portion of the laser beams.

For maximum signal strength, the interferometer and retroreflector are aligned so the reference beam from the interferometer and the measurement beam from the retroreflector exactly overlap upon recombination. These recombined laser beams then enter the receiver at the center of its input lens. From Figure 8-3, it is clear that if the recombined laser beams entering the receiver are not centered on the photodetector, measurement signal loss will occur. If the

Agilent 10780C and Agilent 10780F Receivers

interferometer or the retroreflector is misaligned (Figure 8-3), the reference and measurement beams no longer completely overlap, resulting in signal loss. Typically, a lateral offset of 1/4 of the beam diameter is allowable for an adequate measurement signal. However, you must make every effort to optimize the laser beam overlap for maximum performance.

Optics Misalignment

Figure 8-3. Effect of optics misalignment

If the measurement beam is not aligned parallel to the direction of retroreflector travel, there are two effects.

- First, a cosine error is generated of a magnitude directly related to the angle of misalignment. For a complete description of cosine error, refer to Chapter 15, “Accuracy and Repeatability,” in this manual.
- Second, when movement occurs between the optics, the angular misalignment also causes a lateral displacement of the measurement beam with respect to the reference beam at recombination, resulting in additional signal loss. Figure 8-4 illustrates the result of angular misalignment.

Angular Misalignment

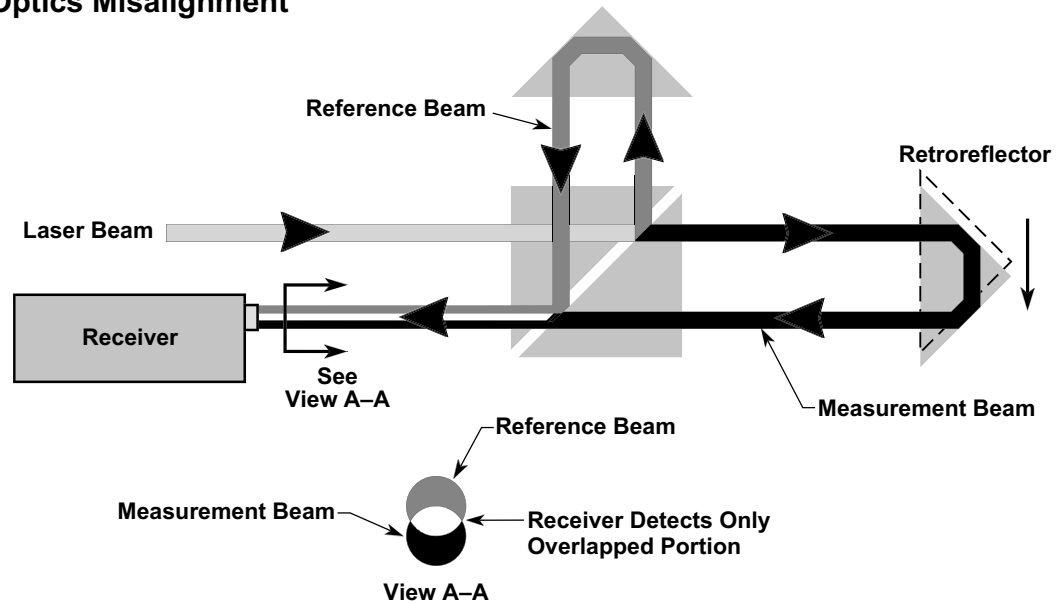
Figure 8-4. Effects of Angular Misalignment to the Direction of Travel

NOTE

The presence of measurement signal through the total length of travel does not guarantee that the measurement axis is aligned for minimum cosine error. Also, any angular misalignment of the laser beam to the direction of travel causes a decrease in the measurement signal strength.

Receiver alignment and gain adjustment procedure

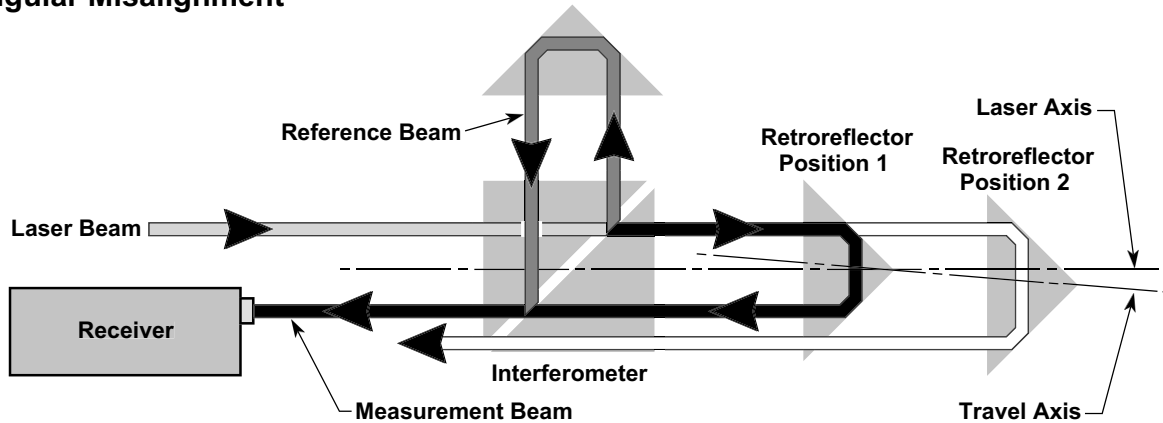
The procedures presented here are common to most of the alignment procedures or techniques presented in Chapter 4, “System Installation and Alignment,” and Chapter 7, “Measurement Optics,” of this manual. Usually, aligning the receiver and adjusting its gain will be done after all other optics alignment has been done.

Agilent 10780C and Agilent 10780F Receivers

To align and adjust the Agilent 10780C or Agilent 10780F receiver:

- 1** Align the optics on the machine in the desired configuration. See the alignment procedures or techniques applicable to the interferometer(s) or wavelength tracker installed in your system. Use alignment targets, alignment aids, or both, to establish proper beam spacing and positioning.
- 2** Run the system stage out to its limit such that the retroreflector or plane mirror for one axis is at its furthest position from the interferometer.
- 3** Mount the Agilent 10780C or Agilent 10780F receiver on that axis, if this has not already been done.
- 4** Connect a digital voltmeter (DVM) or oscilloscope to the test point on the back of the receiver.
- 5** Align the receiver for a maximum positive voltage at the test point. You may have to adjust the gain potentiometer to keep the test point voltage out of saturation and in the linear region (0.1 to 0.8V).

NOTE

A simple way to align the receiver is to use a gage block to autoreflect the beam. Remember that the objective is to position the receiver or sensor head such that the beam enters the input aperture perpendicular to its front face and centered in the aperture. Hold the gage block against the front face and adjust the receiver or sensor head position and angular orientation so that the beam is autoreflected, that is, coincident upon itself at the laser head.

This will provide excellent alignment of the receiver in pitch and yaw, but not roll, relative to the beam axis. Roll must be aligned so the two polarization vectors from the laser head are parallel to or perpendicular to the plane defined by the centerlines of the two mounting holes, within $\pm 3^\circ$.

-
- 6** Turn the GAIN potentiometer fully clockwise.
 - 7** Block the measurement beam (the beam between the interferometer and the measurement reflector).
 - 8** Adjust the GAIN potentiometer counter-clockwise until the test point voltage drops below 0.1V.
 - 9** Unblock the measurement beam. The test point voltage should be at least 0.7V.

NOTE

Record the voltage reading at the beam monitor test point as an axis reference for future troubleshooting.

Agilent 10780C and Agilent 10780F Receivers

Operation

The Agilent 10780C Receiver or Agilent 10780F Remote Receiver normally receives its operating power from the measurement electronics to which it is connected. When the measurement electronics are turned on, the receiver will turn on.

An LED on the Agilent 10780C or Agilent 10780F receiver signals beam capture.

An available dc voltage output on the Agilent 10780C or Agilent 10780F receiver indicates incoming laser beam intensity.

Specifications and characteristics

Specifications describe the device's warranted performance. Supplemental characteristics (indicated by TYPICAL or NOMINAL) are intended to provide non-warranted performance information useful in applying the device.

Specifications for the Agilent 10780C Receiver and Agilent 10780F Remote Receiver are given below.

Specifications for the Agilent 5519A/B Laser Head's internal receiver are given in Chapter 5, "Laser Heads," of this manual.

Sensitivity

The maximum sensitivity of the Agilent 10780C is 1.5 μW (factory-set at 5 μW) and can be adjusted via an externally accessible potentiometer. The adjustment procedure is given earlier in this chapter.

Maximum sensitivity of the Agilent 10780F Remote Receiver is 2.2 μW with its standard 2 m cable (a 10 m cable reduces the sensitivity to 5.0 μW).

The difference between the Agilent 10780C and the discontinued Agilent 10780A and Agilent 10780B models is the increased bandwidth and sensitivity of the Agilent 10780C to laser light.

Agilent 10780C Receiver Specifications

Weight: 136 grams (4.8 ounces)

Dimensions: see figure below

Typical Power Requirements: +15 volts at 136 mA

Heat Dissipation: 2.0 W typical

Alignment Tolerances:

Roll: ± 3 degrees

Pitch: ± 1 degree

Yaw: ± 1 degree

Maximum Sensitivity: 1.5 μ W

Factory adjusted to 5.0 μ W; can be adjusted to maximum sensitivity using procedures in the Agilent 10780C/F Operating and Service Manual.

Output Signal:

Differential square wave at Doppler-shifted split frequency (100 kHz to 7.2 MHz)

Electrical Cables:

Agilent 10790A: 5 m (15.2 ft)

Agilent 10790B: 10 m (30.5 ft)

Agilent 10790C: 20m (61 ft)

Electrical cables for Agilent 10885A, 10889B, 10896B, 10897B, 10898A, or N1231A axis board:

Agilent 10880A, 5 m (15.2 ft)

Agilent 10880B, 10 m (30.5 ft)

Agilent 10880C, 20m (61 ft)

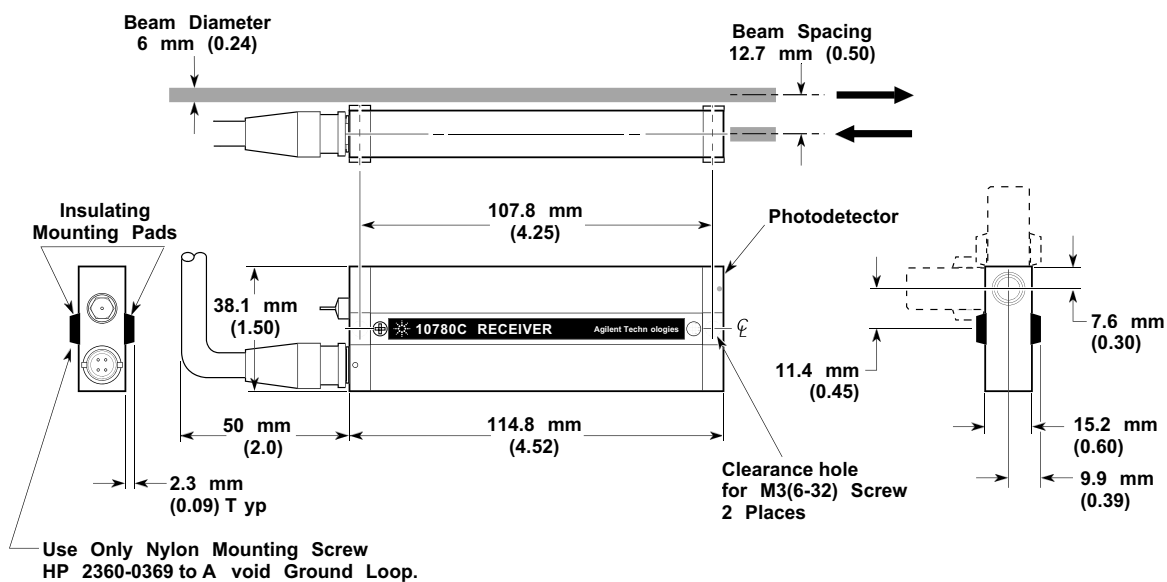

Figure 8-5. Agilent 10780C Receiver — dimensions

Agilent 10780F Remote Receiver Specifications

Weight: 126 grams (4.5 ounces) for Agilent 10780F receiver
26 grams (0.9 ounce) for remote sensor with a 2 meter cable

Dimensions: see figure below

Typical Power Requirements: +15 volts at 136 mA

Heat Dissipation: 2.0 W typical for receiver
0 W for remote sensor

Alignment Tolerances:

- Roll: ± 3 degrees
- Pitch: ± 1 degree
- Yaw: ± 1 degree

Maximum Sensitivity: 2.2 μ W (with 2-meter cable)

Factory adjusted to 5.0 μ W; can be adjusted to maximum sensitivity using procedures in the Agilent 10780C/F Operating and Service Manual. (Becomes 5.0 *W with a 10-meter fiber cable.)

Output Signal:

Differential square wave at Doppler-shifted split frequency (100 kHz to 7.2 MHz)

Electrical Cables:

- Agilent 10790A: 5 m (15.2 ft)
- Agilent 10790B: 10 m (30.5 ft)
- Agilent 10790C: 20m (61 ft)

Electrical cables for Agilent 10885A, 10889B, 10896B, 10897B, 10898A, or N1231A axis board:

- Agilent 10880A, 5 m (15.2 ft)
- Agilent 10880B, 10 m (30.5 ft)
- Agilent 10880C, 20m (61 ft)

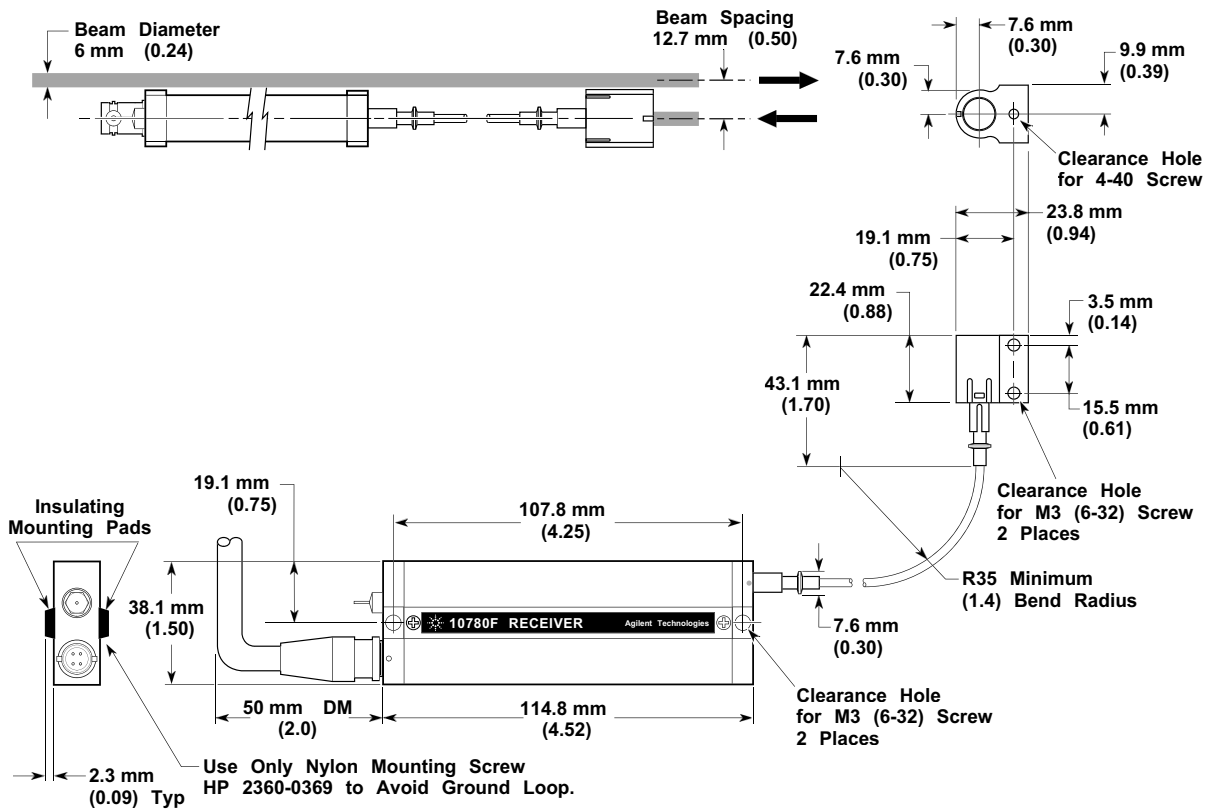

Figure 8-6. Agilent 10780F Remote Receiver — dimensions

Agilent E1708A Remote Dynamic Receiver

Description

The Agilent E1708A Remote Dynamic Receiver, shown in Figure 8-7, is intended for use in applications requiring sub-nanometer resolutions of systems in motion. It extends the performance of systems that use the Agilent 10897B High Resolution Laser Axis board for VMEbus by providing performance consistent with the high resolution and low variable data age of that board. As the Doppler shift caused by motion of the system stage changes the measurement frequency, the Agilent E1708A receiver ensures minimal phase processing errors. The E1708A also provide immunity to errors induced by changes in measurement signal (laser input) power level.

One receiver package is required for each measurement axis in the Laser Transducer system being installed.

The Agilent E1708A receives the laser beam via a remote sensor (Agilent E1706A) containing a lens and polarizer. A fiber-optic cable (Agilent E1705A) carries the beam from the remote sensor to the electronics in the receiver body. The fiber-optic cable length is 2.0 meters to allow for considerable mounting flexibility and ease of use. This arrangement provides several benefits:

- it allows the receiver body to be located well away from the point of beam intercept so receiver heat is not dissipated near the measurement area.
- it makes easier access to the attenuator and squelch adjustments possible, and
- there is a much smaller package size in the measurement area.

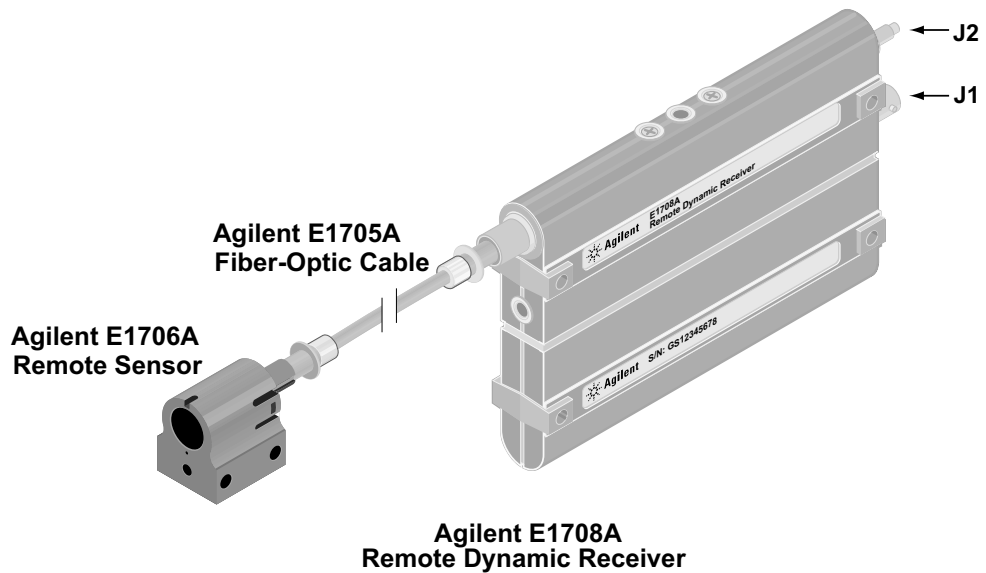
Agilent E1708A Remote Dynamic Receiver**Figure 8-7. Agilent E1708A Remote Dynamic Receiver****Principles of operation**

The Agilent E1708A receiver's body contains the photodetector, preamplifiers, and a detector circuit designed to convert the laser beam returning from an interferometer into a differential square wave at the Doppler frequency (100 kHz to 7.2 MHz). The Doppler frequency contains the measured displacement information (MEAS signal), representing the relative motion between an interferometer and its associated reflector. A squelch circuit allows the receiver's signal output to be turned off automatically if the input signal is not strong enough. A secondary output from the receiver is a dc level that is proportional to the input signal strength. LED indicators on the receiver light when any input signal is detected. For a block diagram, see Figure 8-8.

Agilent E1708A Remote Dynamic Receiver

- 1 Photodetector, amplifier
- 2 Attenuator adjustment
- 3 Amplifier
- 4 LEDs
- 5 Squelch adjustment
- 6 Signal level detector circuit
- 7 Sinewave-to-squarewave converter
- 8 Signal strength connector (J2, see Figure 8-7)
- 9 Output signal/input power connector (J1, see Figure 8-7)

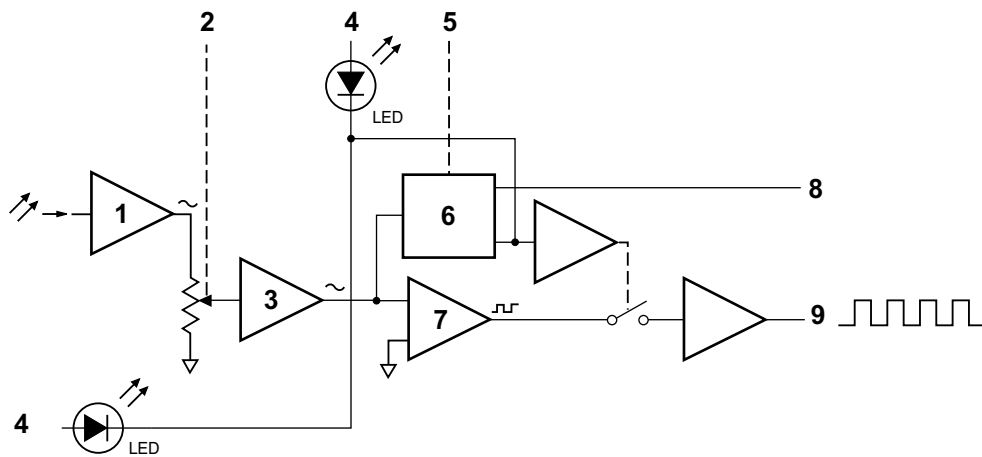

Figure 8-8. Agilent E1708A Receiver—block diagram

Installation

Refer to Agilent 10780C/F Receiver's placement, mounting, installation examples, and procedures for alignment to the laser beam. For more specific mounting, installation, and alignment and adjustment procedures, see the *Agilent E1707A Dynamic Receiver and Agilent E1708A Remote Dynamic Receiver Operating Manual*.

Agilent E1708A Remote Dynamic Receiver**Cables for electronics**

The receiver cable to be used depends on the electronics (system) to be used. Table 8-2 lists the available cables. Refer to the manual for your system for more cabling information.

Table 8-2. Cables for use with an E1708A receiver

For use with these electronics	Use one of these Receiver Cables	Description
Agilent 10885A PC Axis Board	5 meters: Agilent 10880A 10 meters: Agilent 10880B	These cables have a 4-pin BNC connector on one end and a 4-pin LEMO connector on the other.
Agilent 10887A PC Calibrator Board	For cable lengths longer than 10 meters, use high-performance cables.	
Agilent 10889B PC Servo-Axis Board	Contact Agilent for information about high-performance cables.	
Agilent 10896B Laser Compensation Board for VMEbus (with Agilent 10717A Wavelength Tracker)		
Agilent 10897B High Resolution VMEbus Laser Axis Board	Use high-performance cables. Contact Agilent for information.	These cables have a 4-pin BNC connector on one end and a 4-pin LEMO connector on the other.
Agilent 10898A VME High Resolution Dual Laser Axis Board		Use high performance cables for both the receiver and the laser head.
Agilent N1231A PCI Three-Axis Board		
Agilent 10895A Laser Axis Board for VMEbus	5 meters: Agilent 10790A 10 meters: Agilent 10790B	These cables have a 4-pin BNC connector on each end.

Each of these receivers has a polarizer as part of its input lens assembly. The E1708A receiver's lens assembly is in the remote sensor assembly.

When mounting either receiver, remember the following points:

- For maximum input signal strength, align the polarizer so its polarization vectors are the same as those of the incoming laser beam. At a 45-degree roll position, the signal goes to zero.
- For either receiver body, power dissipation is typically 3.8 watts. The receiver's mounting feet keep an air gap around the receiver and also act as thermal and electrical isolators.
- Leave enough clearance for the signal cable that connects to the receiver's 4-pin signal and power connector. (See dimensional drawing in Figure 8-10)
- The receiver housing must be electrically isolated from the equipment it is mounted on. The clearance holes in the receiver's insulating mounting feet let you use either 6-32 or M3.5 screws.

CAUTION

When installing or removing the fiber optic cable from the receiver body or sensor head, **DO NOT PULL ON THE CABLE PROPER, GRIP THE CONNECTOR AND PULL IT STRAIGHT OUT** (see Figure 8-9).

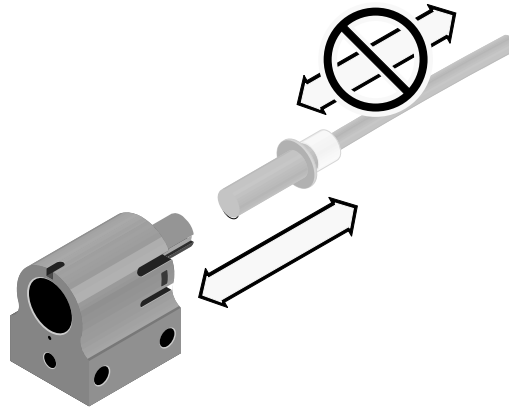

Figure 8-9. Grip and fiber-optic cable connector

Agilent E1705A Fiber-Optic Cable considerations

The Agilent E1705A Fiber-Optic Cable supplied with the Agilent E1708A receiver is 2.0 meters long (The Agilent E1705A cable comes in different lengths and is made of plastic or glass. Contact Agilent Call Center to order a fiber-optic cable of your preference; telephone numbers of various call centers are listed on the “Service and Support” page at the back of this manual). The radius of any bend should be 35 mm (1.4 inches) or more. When coiled to take up excess cable slack, the coil diameter should not be less than 150 mm (6 inches). Details of coiling are given below.

Agilent E1708A Remote Dynamic Receiver

See Table 8-3 for fiber optic cable characteristics that require special handling and consideration for installation and operation.

Table 8-3. Fiber optic cable considerations





Attribute	Description, comment, etc.
<p>Attenuation</p>	<p>Normal cable attenuation is covered by the Sensitivity section of the Specifications in Appendix A.</p> <p>Attenuation due to environmental changes is covered in the information below.</p>
<p>Temperature Sensitivity</p> 	<p>The fiber optic cable is relatively insensitive to temperature changes. The only characteristic that is affected is the cable attenuation, which changes only 2 to 3 percent from 0 to 50 degrees C. Note that measurement accuracy is unaffected by amplitude variations.</p>
<p>Lifetime</p> 	<p>When the cable is flexed continuously around a small radius, the cable will develop permanent attenuation. The attenuation increases as the flexing continues. Using a larger bend radius allows a considerable increase in lifetime. The lifetime specification is 1000 cycles with a 90-degree bend around a 10-millimeter (0.4-inch) radius. In tests using a 75-millimeter (3.0-inch) bend radius, the cables survived more than 260,000 cycles of bending with no increase of signal attenuation. <i>Cables in permanent installations should not have bends less than 35 millimeters (1.4 inches) radius. If the cable must flex repeatedly, the bend radius should not be less than 100 millimeters (4 inches).</i></p>
<p>Coiling Excess Cable</p> 	<p>The cable coil diameter should be 150 millimeters (6 inches) or larger, to avoid any increase in attenuation.</p>
<p>Environmental Considerations</p> 	<p>The fiber optic cables are UL-recognized components that pass UL VW-1 flame retardancy specifications. In most instances, the use of conduit is probably not necessary, since the cable has excellent safety properties in flammable environments. Also, the cable is electrically non-conductive, so it requires no shielding.</p>

Table 8-3. Fiber optic cable considerations (Continued)

Attribute	Description, comment, etc.
	<p>The cable's polyethylene jacket provides protection against abrasion and chemicals. Avoid placing the cable directly in organic or alkaline solvents for extended periods of time (hundreds of hours), since these chemicals can penetrate the polyethylene jacket and degrade the optical properties of the fiber.</p>
	<p>The fiber cable is specified to withstand a 0.5 kilogram weight shaped in the form of a half-cylinder that is dropped from a height of 150 millimeters.</p>
<p>Cable Bending and Movement</p> 	<p>Shaking, bending and vibration of the cable will not result in measurement errors, but can cause signal attenuation. If the movement is periodic and continuous, amplitude modulation can occur, with the amplitude depending on the bend radius. Amplitude modulation can cause signal attenuation but not measurement errors.</p>

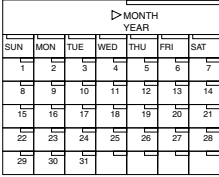
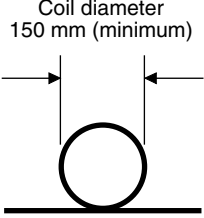
Alignment and adjustments

To aid in aligning the laser beam, three features are available:

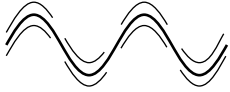
- Initial receiver positioning and coarse beam alignment are achieved with a snap-on beam target fixture (Agilent part number 10780-40009) which is supplied with the receiver. The target is for beam alignment only, and should be removed before operating the receiver.
- LEDs on the top and front of the receiver light to provide visual indication that the receiver photo detector has received both frequency components of the laser beam.
- A dc voltage, which is a function of the incoming laser signal level, is made available for assistance in fine-tuning the laser beam alignment.

The remote sensor allows the receiver's body to be located well away from the point of beam intercept. Some Agilent interferometers allow for direct mounting of the remote sensor.

Operation

Two LEDs light to indicate that the receiver's photodetector has received the laser beam. If the LEDs do not light during operation, try adjusting the attenuator and squelch controls, as described in the "Alignment and Adjustments" of the *Agilent E1707A Dynamic Receiver and Agilent E1708A Remote Dynamic Receiver Operating Manual*

Specifications and characteristics

Specifications describe the device's warranted performance. Supplemental characteristics (indicated by TYPICAL or NOMINAL) are intended to provide non-warranted performance information useful in applying the device.

Specifications for the Agilent E1708A Remote Dynamic Receiver are provided in the following subsection.

Agilent E1708A Remote Dynamic Receiver Specifications

Weight: 170 grams (6.0 ounces)

26 g (0.9 ounces) for remote sensor with 2-m cable

Dimensions: see figure below

Typical Power Requirements: +15 volts \pm 1V at 250 mA maximum

Heat Dissipation: 3.8 W typical for receiver
0.0 W for remote sensor

Alignment Tolerances:

Roll: \pm 3 degrees

Pitch: \pm 1 degree

Yaw: \pm 1 degree

Maximum Sensitivity: 2.2 μ W (E1708A with 2-m cable)
5.0 μ W (E1708A with 10-m cable)

Output Signal:

Differential square wave at Doppler-shifted split frequency (100 kHz to 7.2 MHz). (Designed to operate with Agilent laser boards.)

Signal Strength Monitor: 0-8 volts proportional to optical input signal

Electrical Cables:

Agilent 10790A, 5 m (16.4 ft)

Agilent 10790B, 10 m (32.8 ft)

Agilent 10790C, 20 m (65.6 ft)

Electrical cables for Agilent 10885A, 10889B, 10896B, 10897B, 10898A, or N1231A axis board:

Agilent 10880A: 5 m (16.4 ft)

Agilent 10880B: 10 m (32.8 ft)

Agilent 10880C: 20m (65.6 ft)

or high performance electrical cables:

Agilent N1250A 5 m (16.4 ft)

Agilent N1250B 10 m (32.8 ft)

Fiber-Optic Cables Length:

2 m standard

10 m maximum

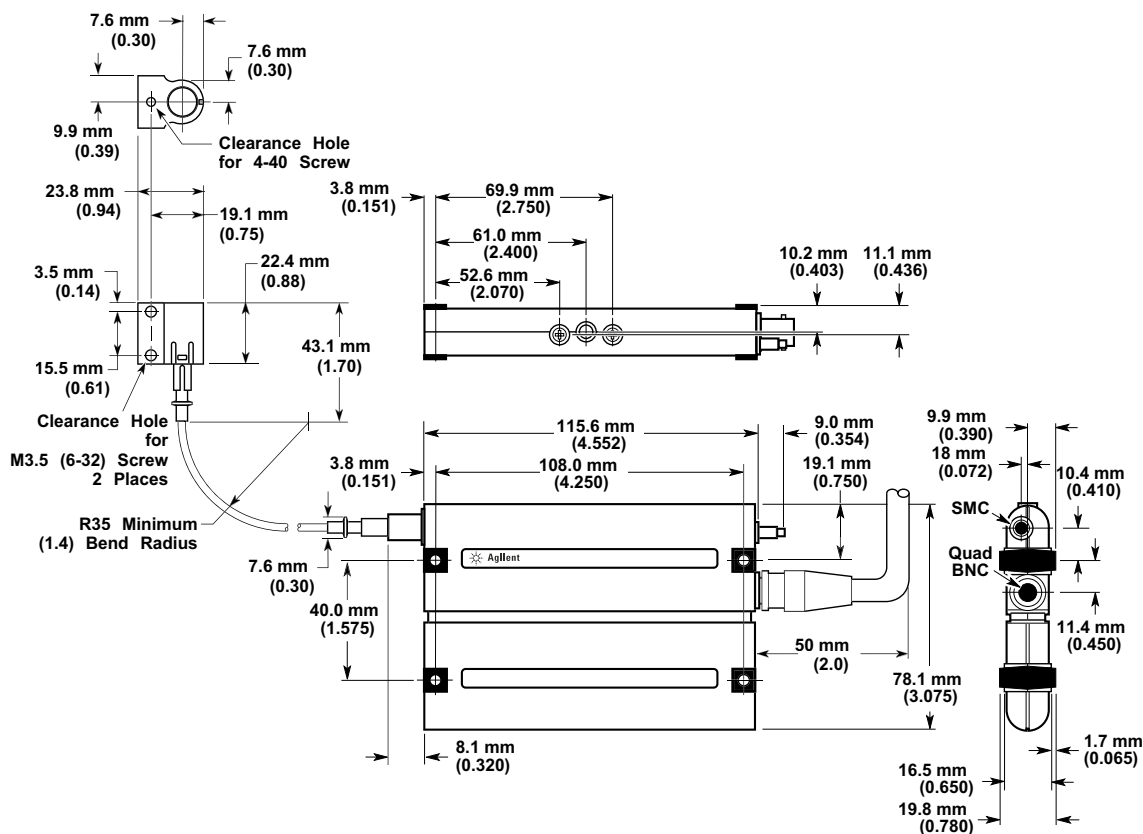

Figure 8-10. Agilent E1708A receiver — dimensions

Agilent E1709A Remote High-Performance Receiver

Description

The Agilent E1709A Remote High-Performance Receiver (see Figure 8-11) is an important component of the measurement electronics for an Agilent Laser Interferometer Measurement System. The Agilent E1709A converts light from the remote sensor to electrical signals that can be processed by the system electronics (See Figure 8-14). The Agilent E1709A is for use in the most demanding applications requiring sub-nanometer resolutions of systems in motion. As the Doppler shift caused by motion of the system stage changes the measurement frequency, the Agilent E1709A receiver ensures minimal phase (position) processing errors. The E1709A also provides immunity to errors induced by changes in measurement signal power level.

One receiver is required for each measurement axis in the Laser Transducer system being installed. See the *Agilent E1709A Remote High-Performance Receiver Operating Manual* for compatible cable information, as well as signal and connector information.

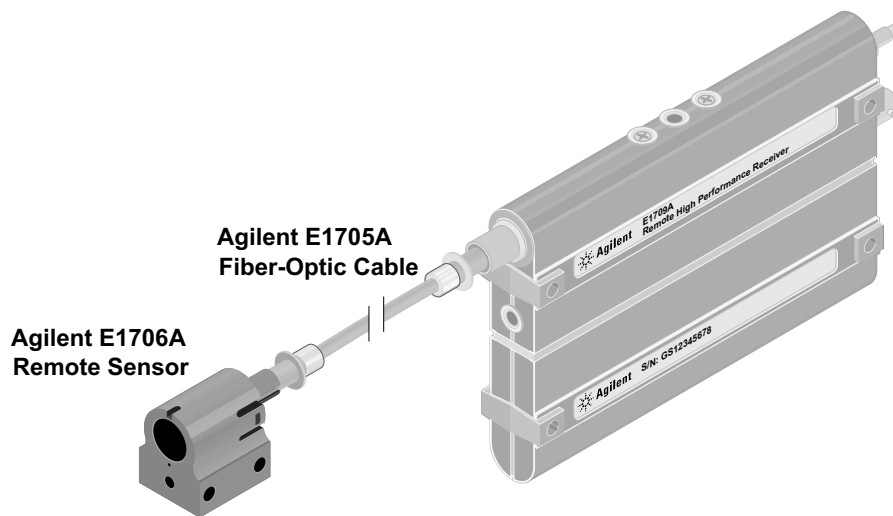

**Agilent E1709A
Remote High Performance Receiver**

Figure 8-11. Agilent E1709A Remote High-Performance Receiver

Key definitions and concepts

Sensitivity dependencies are explained in terms of AC/DC ratio. It is important to understand this concept and how its measurement relates to the resultant electrical output of the Agilent E1709A receiver. Understanding the following terms will also clarify the differences between the Agilent E1708A and the Agilent E1709A, which are discussed and listed later in “Agilent E1709A relationship to Agilent E1708A” subsection in this chapter. The definitions include references to connectors (J2 and J3), shown in Figure 8-14. Detailed descriptions of the Agilent E1709A connectors and signal outputs are covered in *Agilent E1709A Remote High-Performance Receiver Operating Manual*.

Figure 8-12 illustrates the ac and dc light power relationship.

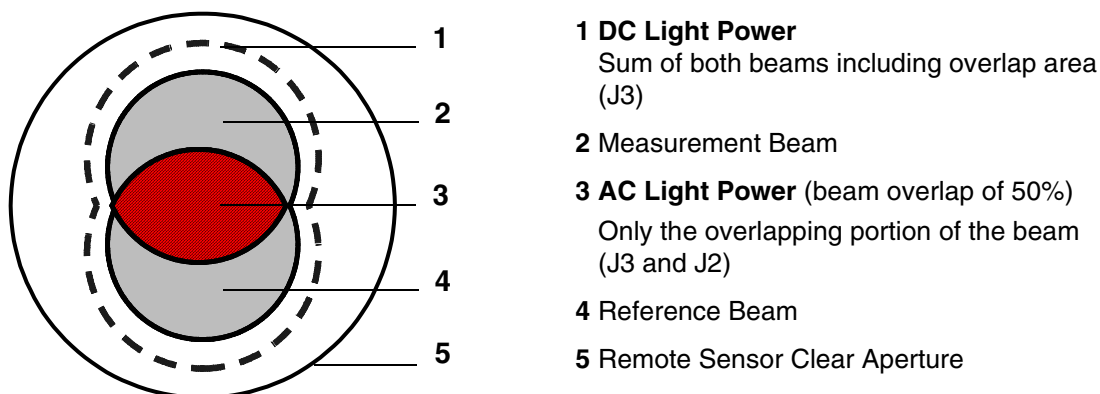

Figure 8-12. AC/DC light power relationship

DC Light Power — In the Agilent laser measurement system, the receiver captures the light power (intensity) from the two beams, the Measurement Beam and the Reference Beam, which are at slightly different frequencies. The sum of the light power in each beam is the dc component of the light power (assuming both beams are within the sensor clear aperture area).

NOTE

For the Agilent E1708A, the dc portion of the laser beam has little impact on the specification. However, with the Agilent E1709A, the amplitude of the dc light signal directly affects the receiver sensitivity. Therefore, it is important to measure both the ac and the dc components at the First Stage Output.

Agilent E1709A Remote High-Performance Receiver

AC Light Power — When the two beams overlap, this produces a *difference frequency* (split frequency), which is detected by the receiver as the ac component of the light power. It is the ac light power that is converted to an electrical signal, which becomes the *measurement frequency*.

AC/DC Ratio — This is the proportion of ac light power to the total dc light power. For example, Figure 8-12 shows the AC/DC ratio as approximately 50%. The importance of the AC/DC ratio is discussed in detail in Chapter 3 of the *Agilent E1709A Remote High-Performance Receiver Operating Manual*. The alignment procedure described in Chapter 4 of the Operating Manual involves calculating the AC/DC ratio and comparing the values to the Agilent E1709A specifications.

First Stage vs. Second Stage — In the first stage of the Agilent E1709A electronics, both the dc and the ac signals are present. In the second stage, the dc is stripped away and only the ac signal is used to create the receiver output signal. The first and second stages are shown in Figure 8-13.

Agilent E1709A Remote High-Performance Receiver

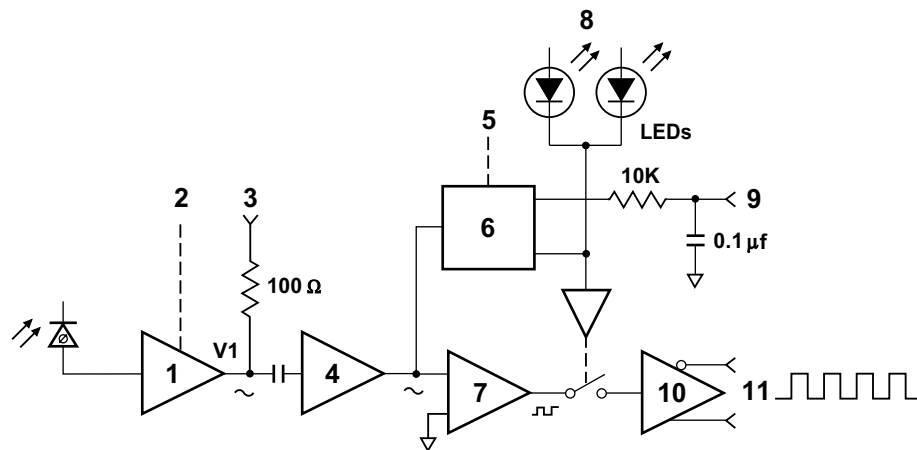

- 1 Photodetector, first stage amplifier
- 2 Attenuator adjustment
- 3 First Stage Output (J3 connector)
- 4 Second stage amplifier
- 5 Squelch adjustment
- 6 Signal strength detector circuit
- 7 Sinewave-to-squarewave converter
- 8 LEDs
- 9 Signal strength voltage (J2 connector)
- 10 Cable driver
- 11 Output signal/input power (J1 connector)

Figure 8-13. Agilent E1709A Receiver block diagram

Figure 8-14 illustrates the location and signal characteristics of J2 and J3.

Agilent E1709A Remote High-Performance Receiver

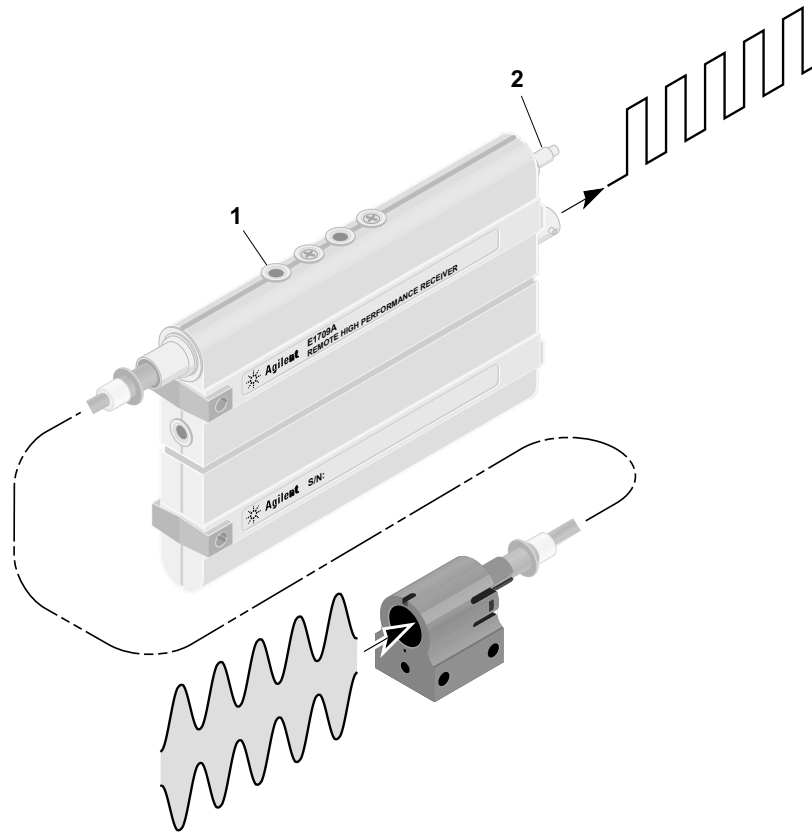

Reference	Description
1	J3 First Stage Output Indicates ac and dc portions of the light signal.
2	J2 Signal Strength Voltage indicates only the ac portion of light signal as a dc voltage. This is an SMC connector. An SMC (f) to BNC (f) Adapter (Agilent part number 1250-0832) is available.

Figure 8-14. Agilent E1709A with fiber and lens assembly

First Stage Output Voltage (J3)—This is the actual output voltage of the Agilent E1709A's first electrical stage. It contains both the dc and ac portions of the incoming light signal and hence is used to determine the AC/DC ratio. This signal **is** affected by adjustments of the Agilent E1709A attenuator.

Signal Strength Voltage (J2)—This is a dc voltage that is proportional to the ac component of the signal at the output of the second electrical stage. This signal **is** affected by any adjustments of the Agilent E1709A attenuator. This dc voltage should not be confused with the dc light signal component.

Features

Agilent E1706A Remote Sensor

The Agilent E1709A requires an Agilent E1706A Remote Sensor containing a lens, polarizer, and Agilent E1705A Fiber-Optic Cable that can be purchased separately or as an option to the Agilent E1709A. Glass or plastic fiber cables are available. Contact Agilent call center for details. The fiber-optic cable carries the beam from the remote sensor to the electronics in the receiver body. The fiber optic cable length is 2.0 meters to allow for considerable mounting flexibility and ease of use (if you require some length other than the standard 2.0 meters, contact Agilent call center). This arrangement provides several benefits:

- It allows the receiver body to be located well away from the point of beam intercept so receiver heat is not dissipated near the measurement area.
- It provides easier access to the attenuator and squelch adjustments.
- It provides a much smaller package size in the measurement area.

Application characteristics

The Agilent E1709A:

- Has high sensitivity of .20 μ to 0.80 μ W depending on ac signal strength with a 2-meter cable.
- Accommodates a high Doppler frequency shift to allow greater speed in stage velocity with slew rates to 1m/s with plane mirror optics.
- Has a wide operating temperature range of 0-40° C.
- Has a wide Dynamic Range of 25:1 to 6:1, depending on ac signal strength.

Agilent E1709A relationship to Agilent E1708A

There are several additional features provided by the Agilent E1709A that are not provided by earlier model receivers such as the Agilent E1708A Remote Dynamic Receiver. For detailed comparison of Agilent E1708A and Agilent E1709A, see Table 8-1.

Technical enhancements

The Agilent E1709A, compared to the Agilent E1708A:

- has 3 to 11 times greater sensitivity, enabling the measurement system to function with weaker beam signal. This allows a much longer distance between receiver and sensor or more axes per laser head.
- accommodates a higher Doppler frequency shift to allow greater speed in stage velocity (slew rate). The Agilent E1709A can tolerate approximately two times the slew rate limit of the Agilent E1708A.
- has approximately 10 times greater immunity to temperature variations.
- allows approximately 5 times more dynamic range (optical power change).

Adjustment and additional alignment requirements

The Agilent E1709A has much greater sensitivity specifications than the Agilent E1708A. In order to obtain the optimum sensitivity performance for the Agilent E1709A, additional measurements and alignment procedures are required to maximize the ratio of ac light signal to dc light signal at the receiver input. Figure 8-12, illustrates ac light and dc light at the receiver input.

The Agilent E1709A features an oscilloscope probe connection to measure the AC/DC ratio.

Retrofit issues

The Agilent E1709A can be used in most applications where the Agilent 10780F or Agilent E1708A is used. In most respects, the Agilent E1709A has better specifications than these other receivers, and will perform as well or better. However, several specifications should be checked.

- Size is the same as the Agilent E1708A and larger than the Agilent 10780F.
- Maximum AC Optical Signal Intensity specification is 50 μ W for the Agilent E1709A, which is 4 times less than for the Agilent E1708A.

Agilent E1709A Remote High-Performance Receiver

The maximum optical signal can be larger if larger position error is acceptable.

- AC/DC ratio is more important for the Agilent E1709A than for other Agilent laser system receivers.
- DC power consumption is considerably larger than the Agilent 10780F and slightly larger than the Agilent E1708A.
- Agilent recommends the use of a scope probe to align the Agilent E1709A. Approximately 130 mm (5 in.) of space above the top of the receiver is needed to allow the scope probe to be plugged in to the J3 connector. The Agilent E1708A (which is almost identical to the Agilent E1709A) does not have a scope probe connector and does not have this space requirement. Therefore, when retrofitting the Agilent E1709A into an Agilent E1708A application, make sure there are provisions for this scope probe access.
- For maximum slew rate, the Agilent 10898A Dual Laser Axis Board and high-performance cables are required.
- When replacing an Agilent 10780C/F with either an Agilent E1708A or Agilent E1709A, metal mounting screws can be used. (Plastic screws are recommended for the Agilent 10780C/F.)

Specifications and characteristics

Specifications describe the device's warranted performance. Supplemental characteristics (indicated by TYPICAL or NOMINAL) are intended to provide non-warranted performance information useful in applying the device.

Specifications for the Agilent E1709A Remote High-Performance Receiver are provided in the following subsection.

Agilent E1709A Remote High-Performance Receiver Specifications

Weight: For Agilent E1709A —190 grams (6.7 ounces)
For remote sensor with 2m cable: 26g (0.9 oz)

Dimensions: see Figure 8-15 on next page

Typical Power Requirements:

+15 volts $\pm 1V$ at 267 mA maximum

Heat Dissipation: 4.0 W typical for receiver
0.0 W for remote sensor

Temperature Range: 0-40 °C operating

Warm-up Time: 45 minutes typical for still air
15 minutes typical for 60 m/min (200 ft/min) moving air

Optical Input:

Dynamic Range ratio: 25:1 to 6:1, depending on the AC/DC ratio.

Maximum input: 50 μW ac, 150 μW dc

Output Signal:

Differential square wave at Doppler-shifted split frequency (100 kHz to 15.5 MHz). (Slew rates to 1 m/s with plane mirror optics, 2 m/s with linear optics.)

Fixed Data Delay: 33.2 ns (typical)

Fixed Delay Temperature Coefficient: 0.015 ns/°C

Errors due to Doppler frequency variations and amplitude variations (within the Dynamic Range ratio specification):

± 1.2 nm for linear optics

± 0.6 nm plane mirror optics

± 0.3 nm for high resolution optics

For overdrive condition, errors are two times these values.

Signal Strength Voltage: 0-10 volts proportional to ac optical input signal

Alignment and Sensitivity: see table below.

Recommended Electrical Cables for Agilent 10885A, 10889B, 10896B, 10897B, 10898A, or N1231A axis board:

Agilent N1250A High Performance Receiver Cable (5 m)

Agilent N1250B High Performance Receiver Cable (10 m)

Agilent N1251A Matching High Performance Laser Head Cable (3 m)

Agilent N1251B Matching High Performance Laser Head Cable (7 m)

Fiber Optic Cable Type	Remote Sensor Alignment Tolerance	Sensitivity*			
		AC/DC ratio			
		90%	50%	20%	10%
2 m plastic	Roll: $\pm 3^\circ$ Pitch: $\pm 1^\circ$ Yaw: $\pm 1^\circ$	0.20 μW	0.26 μW	0.46 μW	.80 μW

*See the *Agilent E1709A Remote High-Performance Receiver Operating Manual* (Agilent Part Number E1709-90006, English or E1709-90007, Japanese) for more details on sensitivity.

Agilent E1709A Remote High-Performance Receiver

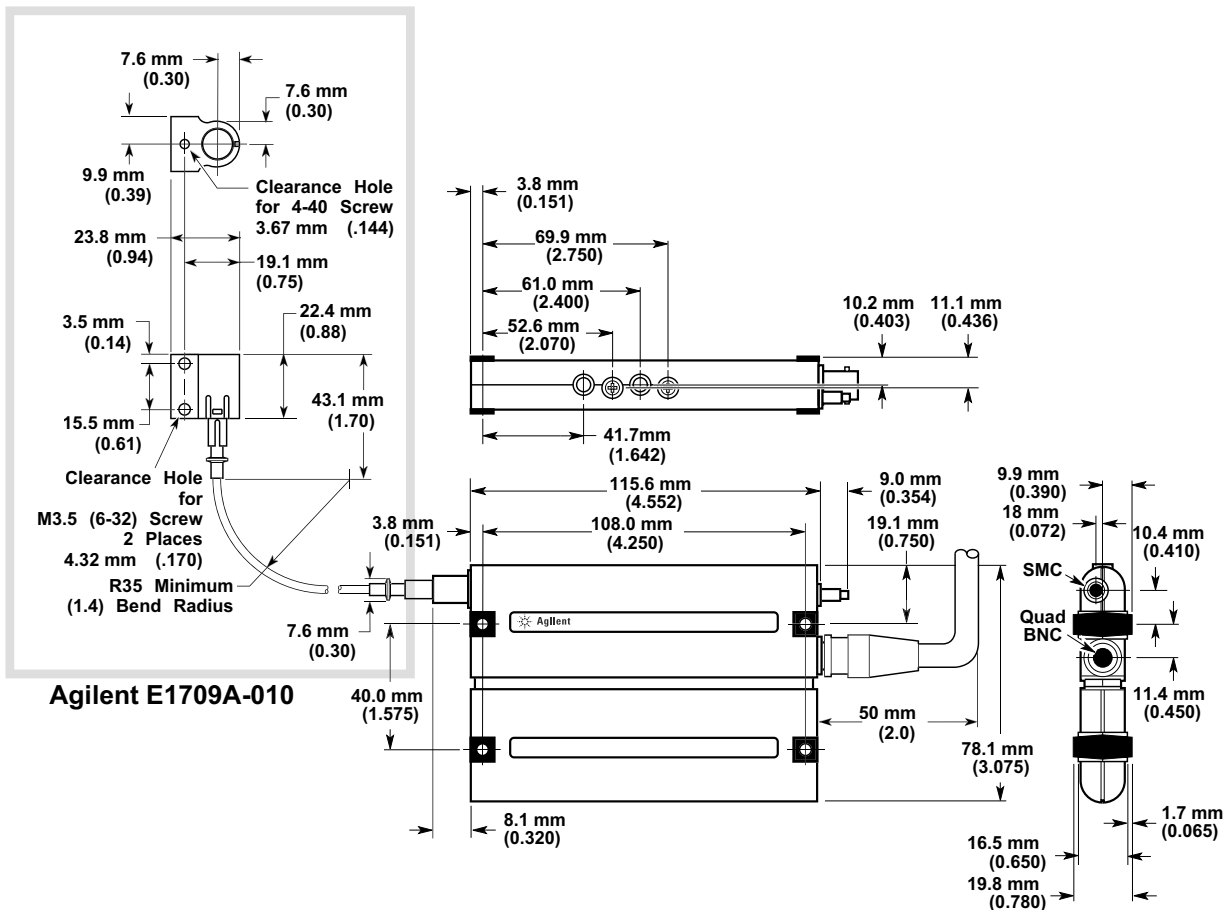

Figure 8-15. Agilent E1709A receiver — dimensions

Product specifications and descriptions in this document subject to change without notice.
Copyright (C) 2002 Agilent Technologies
Printed in U.S.A. 07/02
This is a chapter from the manual titled:
Laser and Optics User's Manual
For complete manual, order:
Paper version: p/n 05517-90045
CD version: p/n 05517-90063
This chapter is p/n 05517-90134