

Keysight Technologies

Balanced Circuit Measurement with an Impedance Analyzer/LCR Meter/ Network Analyzer

Application Note

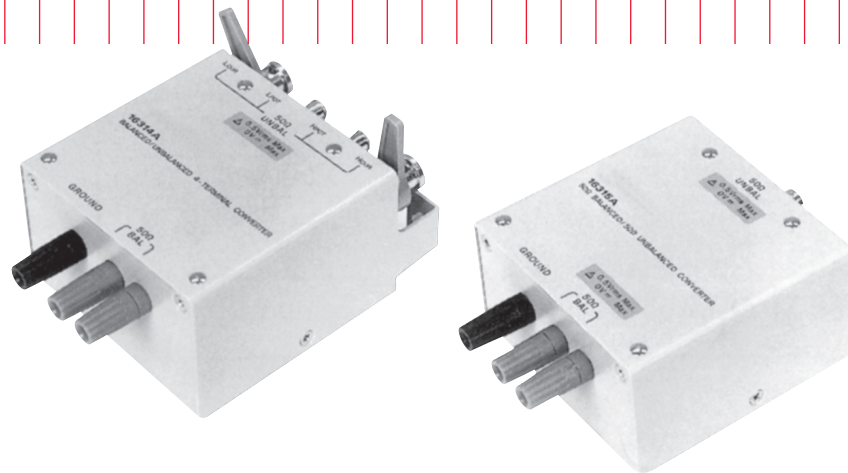

Introduction

How a balanced circuit differs from an unbalanced circuit

A balanced circuit has its electrical midpoint grounded. An unbalanced circuit, however, has one side grounded. A balanced circuit is typically used in communications equipment because a balanced circuit has the advantage of better spurious noise suppression.

Figure 1 shows a balanced cable which is an example of a balanced circuit. The voltages of the cable's two conductors are at every point equal in amplitude and opposite in phase. Figure 2 shows an unbalanced cable which is an example of an unbalanced circuit. Most measurement circuits in the Keysight Technologies, Inc. impedance analyzers and LCR meters are unbalanced.

Measuring a balanced circuit with an unbalanced measurement instrument

A balanced circuit cannot be directly measured with an unbalanced measurement instrument because of the difference in their configuration.

When measuring balanced circuits, the unbalanced measuring instrument requires a Balun (balanced to unbalanced) transformer. A Balun is a type of impedance-matching RF transformer.

Figure 3 shows the configuration for measuring a balanced circuit with an unbalanced instrument.

Note: In balanced cable measurements, residual current in the Balun or the measuring instrument can cause measurement errors. To reduce the degree of error, perform open/short and load compensation at the measurement terminals of the Balun.

Selecting a Balun

There are several types and brands of Balun transformers. When selecting a Balun, ensure that frequency is compatible with your measurement requirements. When you measure the impedance parameters of a balanced circuit, you don't have to use the Balun which has the same impedance with the circuit under test. However, when you measure the transmission or reflection of it, you have to use a Balun which has the same impedance with the circuit under test to keep impedance matching. Table 1 shows recommended Balun transformers.

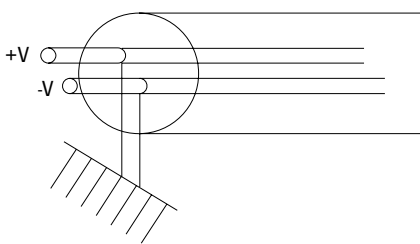

Figure 1. Balanced cable

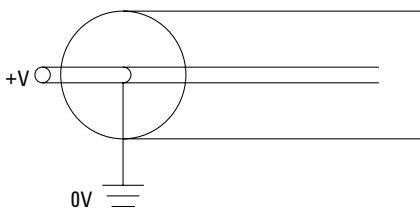

Figure 2. Unbalanced cable

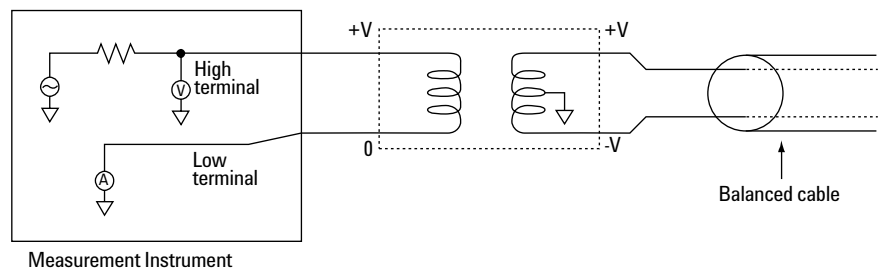

Figure 3. Balanced cable measurement configuration

Measurement Configuration with a Balun and Compensation

Impedance measurement configuration with Keysight 4294A impedance analyzer

Figure 4 shows impedance measurement configuration (1)/(2) with the 4294A.

To calibrate/compensate for (1):

1. Perform open, short, and load compensation at the balanced terminals of the 16314-60011. Use the furnished compensation standards of the 16314-60011.

Standards	0 Ω	PN 04191-85300
	0S	PN 04191-85302
	50 Ω	PN 04191-85301

To calibrate/compensate for (2):

1. Assemble a female BNC connector as shown in Figure 5.

2. Perform open, short, and load calibration at the BNC connector using the following BNC Calibration standards:

Short standard	PN 1250-0929
50 Ω load standard	PN 11593A

3. Remove the connector and connect the DUT. Measure the DUT.

Impedance measurement configuration with the Keysight 4395A(#010)

Figure 6 shows impedance measurement configuration (2) with the 4395A.

Refer to “To calibrate/compensate for (2)” of impedance measurement configuration with 4294A impedance analyzer.

Transmission measurement configuration with a network analyzer

Figure 7 shows transmission measurement configuration (3) with a network analyzer.

To calibrate/compensate:

Short the terminals closest to the DUT to the signal out and to the test port, then perform response/thru calibration.

To calibrate/compensate:

Table 1. Recommended Balun transformers

Unb/Bal. (W)	Bandwidth	Type No.	Suppliers
50:50	100 Hz to 10 MHz	16315-60011	Keysight
50:100	100 Hz to 10 MHz	16316A	Keysight
50:600	100 Hz to 3 MHz	16317A	Keysight
50:50	0.1-125 MHz	0001BB	North Hills Signal Processing
50:75	0.1-125 MHz	0101BB	North Hills Signal Processing
50:100	0.1-125 MHz	0300BB	North Hills Signal Processing
50:600	0.1-65 MHz	0700BB	North Hills Signal Processing
75:50	0.1-100 MHz	1000BB	North Hills Signal Processing
75:75	0.1-100 MHz	1100BB	North Hills Signal Processing
75:100	0.1-100 MHz	1300BB	North Hills Signal Processing
75:600	0.1-60 MHz	1700BB	North Hills Signal Processing

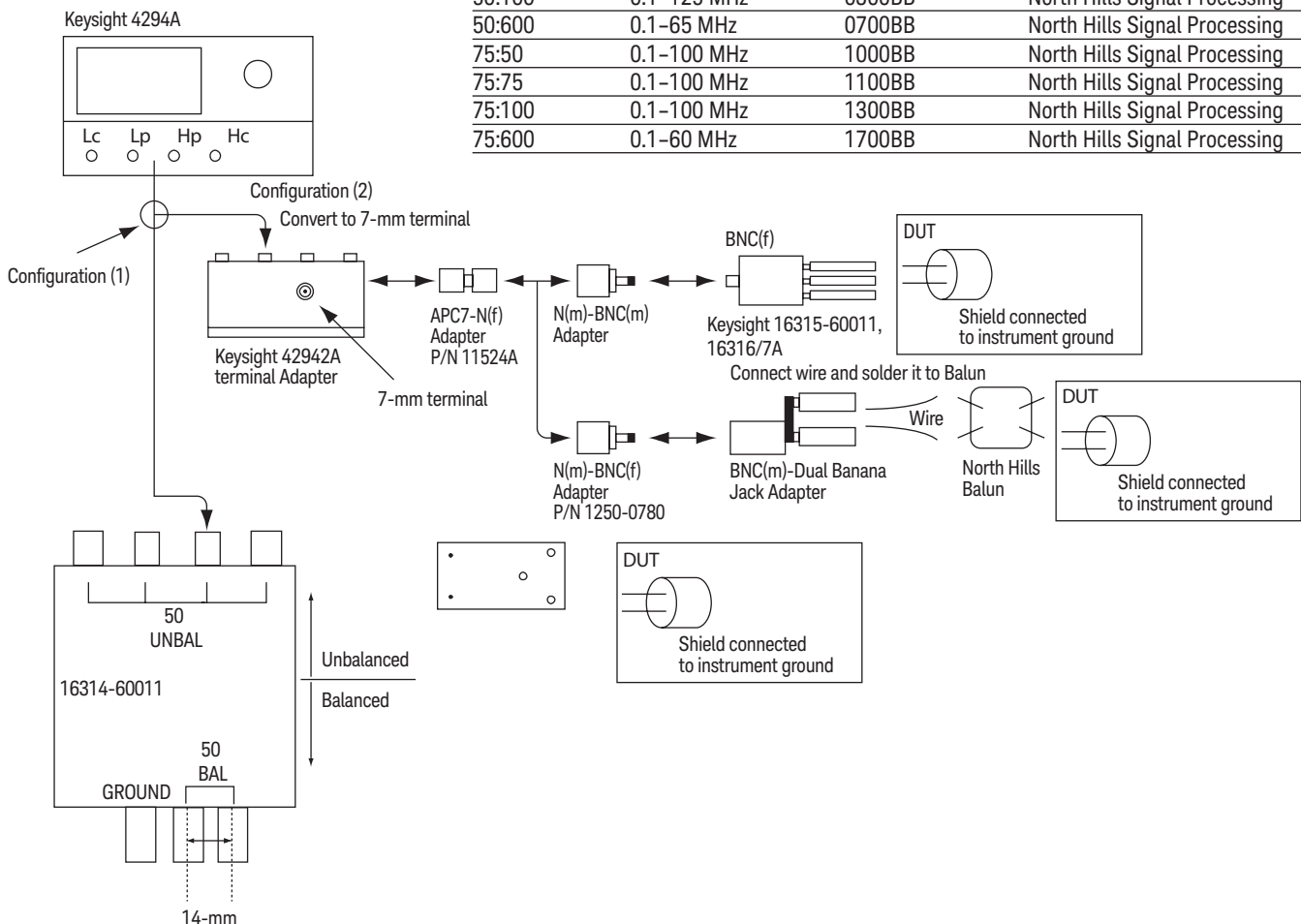

Figure 4. Measurement configurations with 4294A

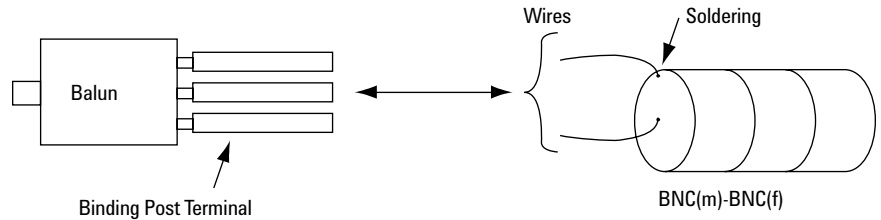
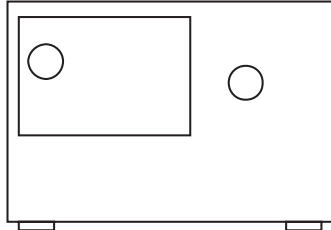
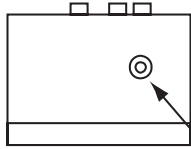

Figure 5. Assembling BNC connector

Keysight 4395A-010



Keysight 43961A impedance test kit



7-mm terminal

7-mm N(f) adapter
P/N 11524A

N(m)-BNC(m) adapter

N(m)-BNC(f) adapter
P/N 1250-0780

BNC(f)

Keysight 16315-60011,
16316/7A

Connect wire and solder it to balun

BNC(m)- dual banana
jack adapter

Wire

North Hills
balun

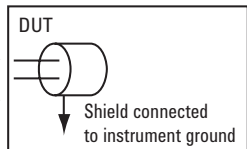
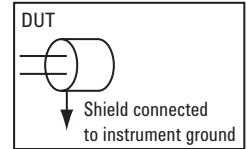

Figure 6. Measurement configuration (2)

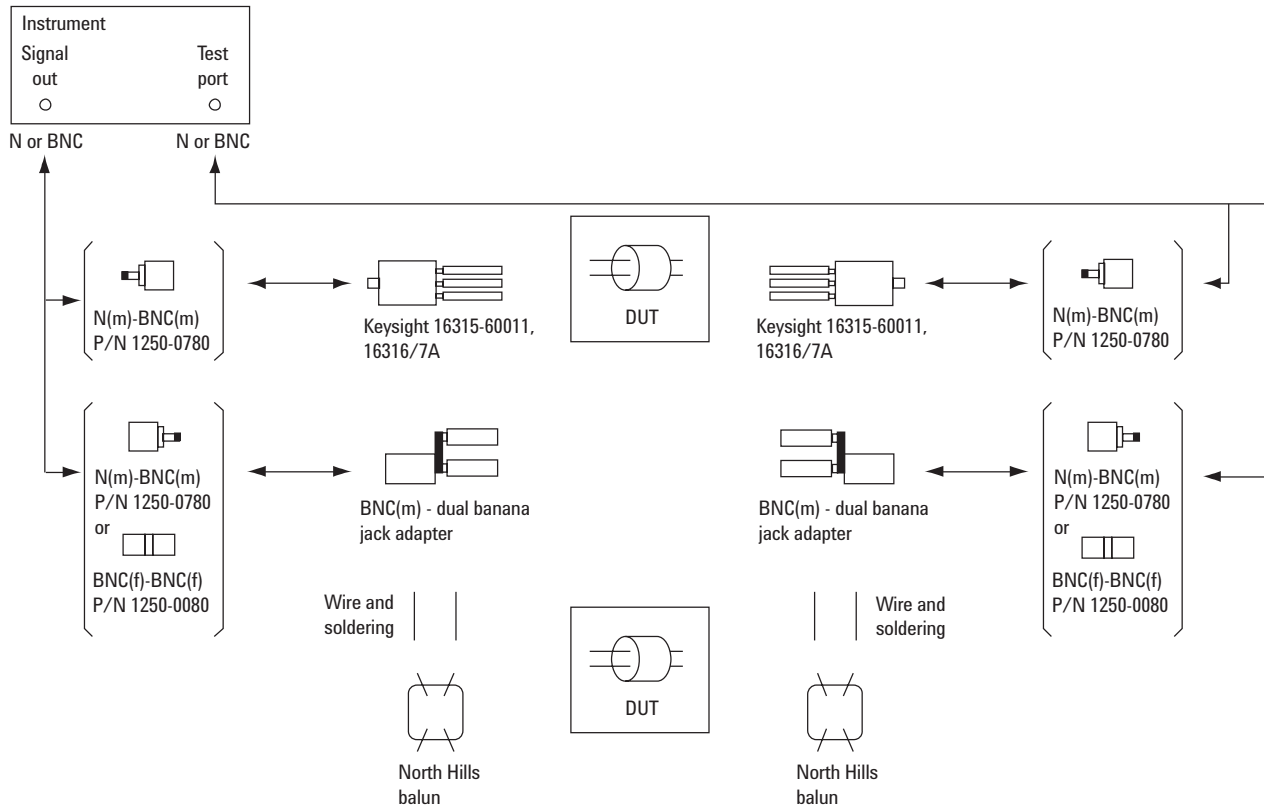

Figure 7. Measurement configuration (3)

Appendix: Balun Transformer Information

Balun transformers are excellent interfaces for measuring balanced components or circuits. They can be used with unbalanced system measurement instruments such as impedance analyzers, LCR meters, and/or network analyzers (that are unbalanced system measurement instruments).

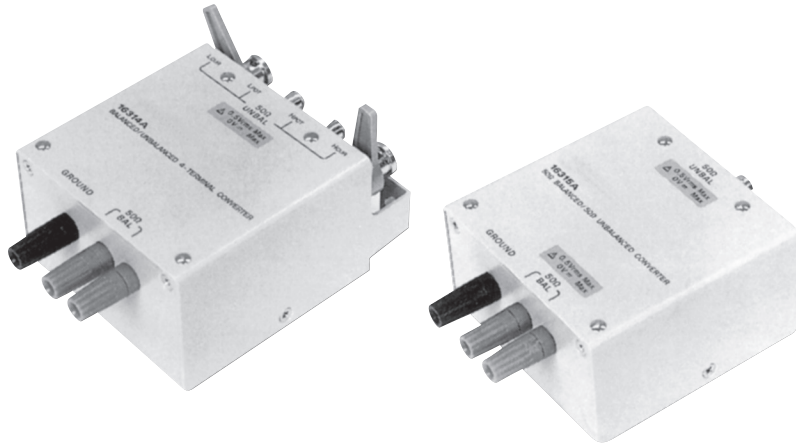

Figure 8. 16314-60011 and 16315-60011

16314-60011

The 16314-60011 can be directly connected to a 4-terminal-pair impedance analyzer or an LCR meter. High-accuracy impedance measurements of balanced devices can be made by using the OPEN/SHORT/LOAD characteristic. This unique feature of the Keysight impedance analyzer and LCR meters is performed at the binding posts by using the furnished shorting plate and a 50 Ω load resistor.

- Wide frequency range (100 Hz to 10 MHz) is covered.
- Recommended instruments:
 - 4294A precision impedance analyzer
 - 4284A precision LCR meter
 - 4285A precision LCR meter
 - E4980A precision LCR meter

16315-60011, 16316A, 16317A

- Reflection and transmission measurements of balanced devices and circuits can be measured with a network analyzer.
- With the furnished load resistor (50 Ω , 100 Ω , 600 Ω) and short plate, calibration can be performed for high-accuracy measurements.
- Depending on the impedance of the device, balanced impedance of 50 Ω , 100 Ω , or 600 Ω can be selected.
- Wide frequency range (100 Hz to 10 MHz (Keysight 16317A covers up to 3 MHz))
- Recommended instruments:
 - 4395A 500 MHz network/spectrum/impedance analyzer
 - 4396B 1.8 GHz network/spectrum/impedance analyzer
 - 4294A precision impedance analyzer

Specifications

Specifications describe the instrument's warranted performance over the temperature range of 0 to 50 °C (except where noted) and after 30-minute warm-up time.

Table 2. Balun transformers specifications

Item		16314-60011	16315-60011	16316A	16317A
Terminal configuration & nominal characteristic impedance	Balanced port	Binding posts 2 signal terminals and 1 ground terminal (signal terminal spacing: 14.0 mm)			
		50Ω	50Ω	100Ω	600Ω
	Unbalanced port	4 BNC connectors	1 BNC connector 50Ω		
Size (mm)		89(W) x 56(H) x 133 (D)		89(W) x 55(H) x 121 (D)	
Weight (g)		400		350	
Operating temperature		0 to 55 °C			
Operating humidity		≤ 95% RH (@ 40 °C)			
Non-operation temperature		-40 to +70 °C			
Non-operating humidity		≤ 90% RH (@ 65 °C)			
Furnished accessories		50Ω load resistor Shorting plate Manual	50Ω load resistor Shorting plate Manual	100Ω load resistor Shorting plate Manual	600Ω load resistor Shorting plate Manual

Supplemental Characteristics

Supplemental characteristics are intended to provide information useful in applying the instrument by giving non-warranted performance parameters.

Table 3. Balun transformers supplemental characteristics (at 23 ± 5 °C)

Item	16314-60011	16315-60011	16316A	16317A
Operating frequency	100 Hz to 10 MHz			100 Hz to 3 MHz
Insertion loss	≤ 1.0 dB (@100 kHz)			
Freq. response	≤ 1.0 dB (relative to the insertion loss at 100 kHz)			≤ ±1.5 dB (relative to the insertion loss at 100 kHz)
Return loss	≤ 10 dB (100 Hz Freq. < 300 Hz)			≤ 10 dB (100 Hz Freq. < 300 MHz)
	≤ 20 dB (300 Hz Freq. < 7 MHz)			≤ 20 dB (300 MHz Freq. 1 MHz)
	≤ 17 dB (7 MHz Freq. < 10 MHz)			≤ 15 dB (1 MHz < Freq. 3MHz)
Common mode loss	≤ 50 dB (100 Hz Freq. < 3 MHz)			≤ 50 dB (100 Hz Freq. < 1 MHz)
	≤ 45 dB (3 MHz Freq. < 5 MHz)			≤ 45 dB (1 MHz Freq. < 3 MHz)
	≤ 40 dB (5 MHz Freq. < 10 MHz)			

Web Resource

www.keysight.com/find/impedance
www.keysight.com/find/lcrmeters

References

Impedance Measurement Handbook,
Publication Number 5950-3000

For information on Balun, contact the manufacturers:

North Hills Signal Processing
A Porta Systems Company
575 Underhill Blvd.
Syosset, NY 11791
Tel: (516) 682 7740
Fax: (516) 682 7704
www.northhills-sp.com/contact.html

Evolving Since 1939

Our unique combination of hardware, software, services, and people can help you reach your next breakthrough. We are unlocking the future of technology.

From Hewlett-Packard to Agilent to Keysight.

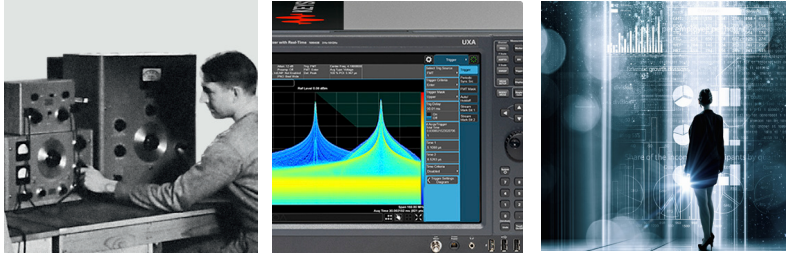

For more information on Keysight Technologies' products, applications or services, please contact your local Keysight office. The complete list is available at: www.keysight.com/find/contactus

Americas

Canada	(877) 894 4414
Brazil	55 11 3351 7010
Mexico	001 800 254 2440
United States	(800) 829 4444

Asia Pacific

Australia	1 800 629 485
China	800 810 0189
Hong Kong	800 938 693
India	1 800 11 2626
Japan	0120 (421) 345
Korea	080 769 0800
Malaysia	1 800 888 848
Singapore	1 800 375 8100
Taiwan	0800 047 866
Other AP Countries	(65) 6375 8100

Europe & Middle East

Austria	0800 001122
Belgium	0800 58580
Finland	0800 523252
France	0805 980333
Germany	0800 6270999
Ireland	1800 832700
Israel	1 809 343051
Italy	800 599100
Luxembourg	+32 800 58580
Netherlands	0800 0233200
Russia	8800 5009286
Spain	800 000154
Sweden	0200 882255
Switzerland	0800 805353
	Opt. 1 (DE)
	Opt. 2 (FR)
	Opt. 3 (IT)
United Kingdom	0800 0260637

For other unlisted countries: www.keysight.com/find/contactus (BP-9-7-17)



www.keysight.com/go/quality
Keysight Technologies, Inc.
DEKRA Certified ISO 9001:2015
Quality Management System

myKeysight

myKeysight

www.keysight.com/find/mykeysight

A personalized view into the information most relevant to you.

http://www.keysight.com/find/emt_product_registration

Register your products to get up-to-date product information and find warranty information.



Keysight Services

www.keysight.com/find/service

Keysight Services can help from acquisition to renewal across your instrument's lifecycle. Our comprehensive service offerings—one-stop calibration, repair, asset management, technology refresh, consulting, training and more—helps you improve product quality and lower costs.

Keysight Assurance Plans

www.keysight.com/find/AssurancePlans

Up to ten years of protection and no budgetary surprises to ensure your instruments are operating to specification, so you can rely on accurate measurements.



Keysight Channel Partners

www.keysight.com/find/channelpartners

Get the best of both worlds: Keysight's measurement expertise and product breadth, combined with channel partner convenience.

This document was formerly known as application note number 346-2.

www.keysight.com/find/impedance

www.keysight.com/find/lcrmeters



This information is subject to change without notice.
© Keysight Technologies, 2017
Published in USA, December 1, 2017
5091-4480E
www.keysight.com