

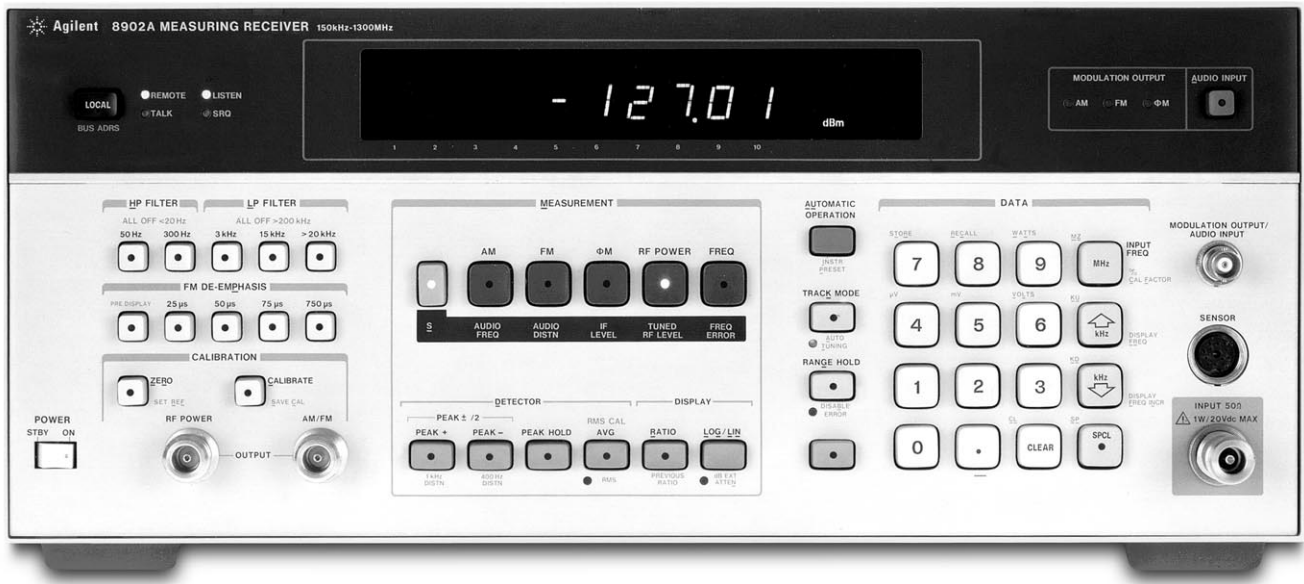

Agilent 8902A

Measuring Receiver

Product Note



Operation of the Agilent 8902A Measuring Receiver for Microwave Frequencies

When you are performing microwave frequency power measurements, the Agilent Technologies 11793A microwave converter extends the superb measurement performance of the 8902A measuring receiver to microwave frequencies. To make measurements on signals from 10 MHz to 1300 MHz, just enter the input signal frequency on the measuring receiver. For input signals above 1300 MHz the signals must be downconverted by the 11793A microwave converter to a usable IF frequency before any measurements can be made by the measuring receiver.

An external local oscillator (LO) provides the correct frequency and amplitude level to the microwave converter for down conversion. The 11793A requires +8 dBm leveled output from the LO. For LO's with insufficient power above 18 GHz, the 11793A offers an optional 10 to 26.5 GHz amplifier. Using the following instructions you can select and set the correct LO mixing frequency on the external LO and make all necessary measurements on your device-under-test (DUT), including low level power measurements down to -100 dBm.



Agilent Technologies
Innovating the HP Way

Setting up the External LO and Measuring Receiver

When the DUT's signal is greater than 1300 MHz, you must down convert microwave signals to the frequency range of the measuring receiver by setting the correct external LO frequency and amplitude, and informing the measuring receiver (using special functions) what the external LO settings are. For each input signal frequency change greater than ± 100 MHz, you must also change the frequency of the external LO to maintain the correct down conversion process. See Figure 1 for connection details.

Selecting the LO frequency

We recommend you select an LO frequency that is 120.53 MHz higher than the DUT's input signal. This is the ideal IF frequency (Agilent 11793A IF output to the input on the measuring receiver) for measurement accuracy.

- For example, if the input signal to be measured is 1800 MHz, use an LO of 1920.53 MHz ($1800 + 120.53 = 1920.53$ MHz).
- If the external LO cannot be set 120.53 MHz higher than the DUT's signal due to a minimum LO frequency range of 2000 MHz, use one of the following frequencies, if possible, for optimum measurement performance (added to the test frequency): 240.53, 480.53, 600.53, or 680.53 MHz. These frequencies are recommended because they are half-way between the measuring receiver's internal LO octave bands.
- For example, if the input signal to be measured is 1800 MHz, you can use an LO of 2040.53 MHz ($1800 + 240.53 = 2040.53$ MHz). The lower the IF frequency, the better the performance. Any IF frequency between 10 MHz and 700 MHz can be used.

Set up the external LO for the correct level:

- +8 dBm for LO frequencies <18 GHz (11793A standard or with options)
- +7 dBm for LO frequencies >18 GHz (11793A standard)
- +0 dBm for LO frequencies >18 GHz (11793A Option 001, 011, or 021)

Setting up the measuring receiver for RF measurements

- Press **FREQ**, then the green **AUTOMATIC OPERATION** key, to clear any previous keys.
- Enter **27.3 SPCL**, the LO frequency in MHz, and then press the **MHz** key. If measuring signals <1300 MHz, press the **27.3 SPCL, 0** key, then the **MHz** key. This tells the measuring receiver that the external LO is not needed; or you may enter **27.0 SPCL** to exit Frequency Offset Mode.
- If the DUT's signal is <-15 dBm, enter the DUT's frequency, and then press the **MHz** key to manually tune.
- Repeat the previous two steps if the DUT's frequency is changed more than ± 100 MHz.
- Select a measurement key on the measuring receiver (except RF POWER) to perform the desired measurement. To perform RF POWER measurements, perform the setup in the following section.

Frequency Offset Control:

- 27.0 SPCL** to exit Frequency Offset Mode
- 27.1 SPCL** to re-enter Frequency Offset Mode
- 27.2 SPCL** to display the External LO frequency
- 27.3 SPCL** to Enter/Enable the External LO

Setting up the Measuring Receiver for RF Power Measurements

The calibration factors listed on the sensor head of the Agilent 11722A or 11792A sensor module must be loaded into the measuring receiver's Normal and Frequency Offset Cal Factor tables before you can perform any RF power measurements. If you enter a digit incorrectly while following these instructions just press the CLEAR key and re-enter that step.

Normal cal factor table entry instructions

- Enter **37.9 SPCL** (clears all cal factor storage tables).
- Press the **RF POWER** key. The instrument will display Error 15 indicating no Cal Factors stored.
- Enter **37.3 SPCL**, and the REF CF value, then press the **BLUE** key, then the **MHz** key. This is the Reference Cal Factor (REF CF).

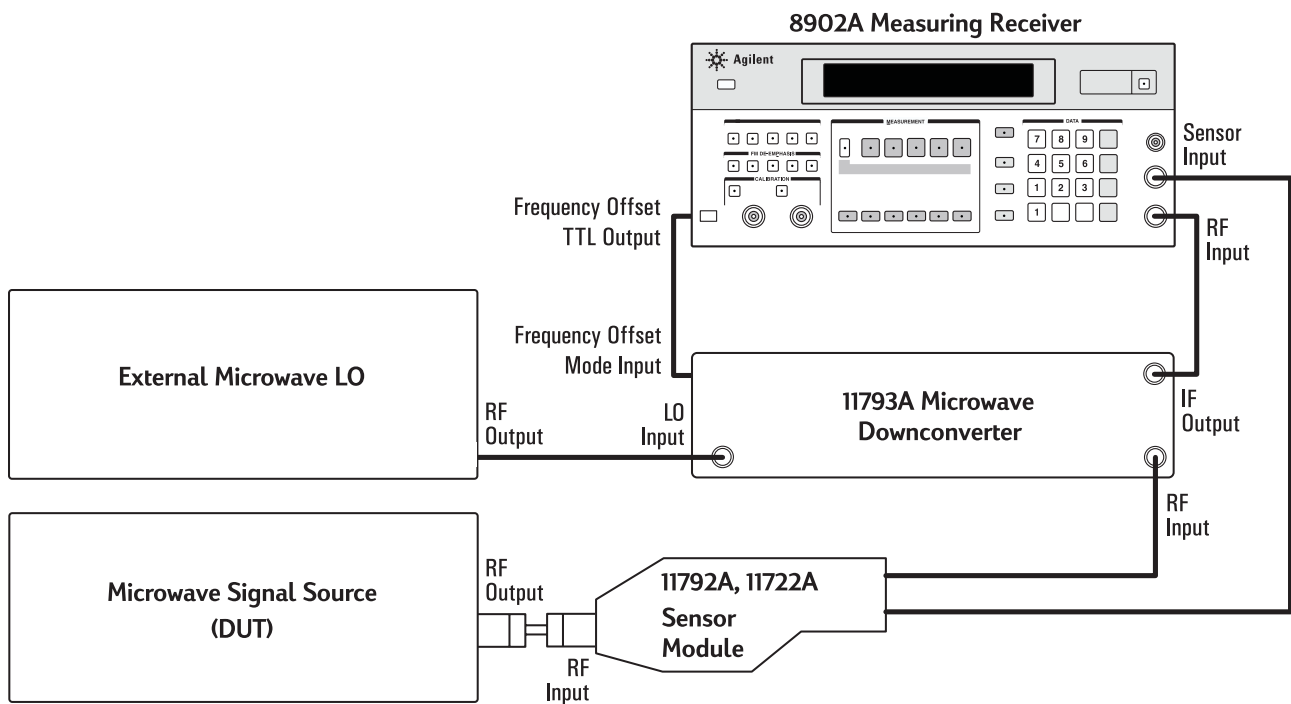

Figure 1. Agilent 8902A Microwave Measurement Interconnections

Setting up the Measuring Receiver for RF Power Measurements (continued)

- Enter **37.3 SPCL**, the frequency in **MHz**, then press the **MHz** key. Enter the Cal Factor % for this frequency, then press the **BLUE** key, then the **MHz** key.
- Repeat the previous step for each Frequency and related Cal Factor shown on the sensor head.
- Press the green **AUTOMATIC OPERATION** key to reset the instrument.

Frequency offset cal factor table entry instructions

- Enter **27.1 SPCL** to enter Frequency Offset Mode.
- Press the **RF POWER** key. The instrument will display Error 15 indicating no Cal Factors stored.
- Enter **37.3 SPCL** and the REF CF value, then press the **BLUE** key, then the **MHz** key. This is the Reference Cal Factor (REF CF).
- Enter **37.3 SPCL**, the frequency in MHz, then press the **MHz** key. Enter the Cal Factor % for this frequency, then press the **BLUE** key, then the **MHz** key.
- Repeat the previous step for each Frequency and related Cal Factor shown on the sensor head.
- Press the green **AUTOMATIC OPERATION** key to reset the instrument.

Verification of the cal factor tables

- Press the **Blue** key, then the **AUTOMATIC OPERATION** key to do an instrument preset.
- Press the **RF POWER** key. If you get Error 15 repeat the Entry Instructions shown on page 3.
- Enter **37.5 SPCL**, then press the **BLUE** key, then the **MHz** key. If the REF CF shown is incorrect, repeat the first three entry instructions for the correct Cal Factor Table Entry Instructions presented in the previous section.
- Enter **37.6 SPCL** then press the **BLUE** key, then the **↑kHz** key. This will display the next frequency in the table; then press the **BLUE** key, then the **MHz** key to display the related cal factor.
- Repeat the previous step to view all entered frequencies and related cal factors.
- To repeat viewing of the table, enter **37.5 SPCL** to start over. To clear the table and start over, enter **37.9 SPCL**.
- To correct any Cal Factor % errors, perform the Cal Factor Entry Instructions only for the frequency and cal factor in error. If a frequency is entered incorrectly, perform Cal Factor Entry Instructions, and enter the frequency in error with a cal factor of zero (**0**). This will erase the frequency from the table.

Performing RF power measurements with a sensor module

- Connect the sensor to the RF POWER, CALIBRATION port on the measuring receiver.
- Press the **ZERO** key, to zero the sensor. After a few seconds 0.00 W is displayed.
- Press the **CALIBRATE** key, to calibrate the sensor. A reading will be displayed.
- Press the **BLUE** key, then the **CALIBRATE** key, to save the reference calibration level (SAVE CAL). 1.000 mW should now be displayed.
- Press the **CALIBRATE** key again to turn off the calibrator.
- The measuring receiver is now calibrated. Measure power levels by pressing **RF POWER**.
- If sensor modules are changed, perform the zero and calibrate steps again.
- Re-calibrate the sensor when ambient conditions change or approximately every 8 hours.

Low-Level RF Power Measurements

The calibration factors listed on the sensor head of the Agilent 11722A or 11792A sensor module must be loaded into the measuring receiver's Normal and Frequency Offset Cal Factor tables to be able to perform any low-level RF power measurements. See the previous sections if this has not been done. The sensor module also must be zeroed and calibrated as described in the previous section. Low-level power measurements can only be performed on a CW signal without modulation.

Setting up the measuring receiver for low-level power measurements

- Set the DUT to the desired frequency, set the amplitude to at least -5 dBm.
- Turn **OFF** all modulation.
- Tune to the DUT's frequency as described in the previous section "Setting up the External LO and Measuring Receiver".
- Press the **GOLD** key (shift), then the **TUNED RF LEVEL** key.
- Press the **BLUE** key and the \uparrow **kHz** key to view the DUT's frequency at any time. The display will clear in approximately 5 seconds and return to the previous reading.
- Press the **LOG/LIN** key for a display of dBm or watts.
- Enter **1.9 SPCL** to insure that 10 dB of attenuation will always be inserted to improve any mismatch uncertainty, or enter **1.0 SPCL** for auto RF input attenuation and gain selection.

Low Level RF Power Measurements (continued)

- The display should show a power reading, the RECAL and the UNCAL annunciators should be lit along with the f OFS (frequency Offset) annunciator (if tuned to a frequency >1300 MHz). The UNCAL annunciator light indicates that the current tuned RF level absolute power measurement is uncalibrated. The RECAL light prompts the user to calibrate.
- Press the **CALIBRATE** key. Calibration may take several seconds. Once a reading is displayed and the RECAL light is no longer displayed, continue.
- Reduce the DUT's signal level in 10 dB steps. You should see a reading at each stepped level. Each time the RECAL annunciator light comes on, press the **CALIBRATE** key (see previous step). Continue this process until -100 dBm is reached. You need to calibrate approximately three times. Now that the three calibration factors for this frequency have been generated, any power level may be measured between +0 dBm and -100 dBm without further calibration.

Setting up the measuring receiver for low-level power measurements on drifting signals

This measurement technique is preferred when you are testing for level accuracy on non-synthesized, or "free running" signal sources that have tendencies to drift in frequency. The Track Mode feature (Special Function 32.9) is used to keep the measuring receiver locked onto drifting signals. When using the Track Mode feature, if the measuring receiver loses the drifting signal, increase the signal to -80 dBm or higher, then press the **BLUE** key, then the **CLEAR** key to retune the measuring receiver to the drifting signal, then continue with your measurement.

- Set the DUT to the desired frequency, set the amplitude to at least -5 dBm.
- Turn **OFF** all modulation.
- Tune the measuring receiver to the DUT's frequency as described in the previous section, "Setting up the External LO and Measuring Receiver".
- Enter **32.9 SPCL**. The TRACK MODE key light should be on. (This is the same as entering 4.4 SPCL, 8.1 SPCL, Log units, Track Mode, and 27.3 SPCL.)
- Press the **MHz** key to enter manual tune tracking mode.
- Press the **GOLD** key (shift), then the **TUNED RF LEVEL** key.
- Press the **Blue** key and the **↑kHz** key to view the DUT's frequency at any time. The display will clear in approximately 5 seconds and return to the previous reading.
- Press the **LOG/LIN** key for a display of dBm or Watts.
- Enter **1.9 SPCL** to insure that 10 dB of attenuation will always be inserted to improve any mismatch uncertainty, or enter **1.0 SPCL** for auto RF input attenuation and gain selection.

- The display should show a power reading, the RECAL and the UNCAL annunciators should be lit, along with the f OFS (frequency Offset) annunciator (if tuned to a frequency >1300 MHz). The UNCAL annunciator light indicates that the current tuned RF level absolute power measurement is uncalibrated. The RECAL light prompts the user to calibrate.
- Press the **CALIBRATE** key. Calibration may take several seconds. Once a reading is displayed and the RECAL light is no longer displayed, continue.
- Reduce the DUT's signal level in 10 dB steps. You should see a reading at each stepped level. Each time the RECAL annunciator light comes on, press the **CALIBRATE** key (see previous step). Continue this process until -100 dBm is reached. You should need to calibrate three times. Now that the three calibration factors for this frequency have been generated, any power level may be measured between +0 dBm and -100 dBm without further calibration.
- The calibration remains valid for any CW signal at that frequency $\pm 5\%$ (or ± 10 MHz (± 5 MHz in Track Mode), whichever is smaller).
- In Tracking Mode, if the DUT's frequency drifts past one of the following frequency boundaries, the measuring receiver will lose the signal and the measurement process must be restarted: 40 MHz, 80 MHz, 160 MHz, 320 MHz, and 640 MHz.
- Higher resolution for dB measurements can be attained by using **32.0 SPCL** for a resolution of 0.01 dB or **32.1 SPCL** for a resolution of 0.001 dB.
- If Error 15 is displayed, you need to enter the cal factors printed on the sensor module.
- If Error 31 or 33 is displayed, the sensor module needs to be zeroed and calibrated.
- Refer to the 8902A Operation and Calibration Manual for more detailed descriptions and other useful functions. See the "Tuned RF Level" section under the "RF Power" and "Level" tab and the "Frequency Offset Control" section under the "Additional Capabilities" tab.

Other useful information when setting up the measuring receiver for low-level power measurements

- The three calibration factors for a frequency can be saved in non-volatile memory in one of the eight STORE/RECALL registers. To store these cal factors for a frequency in register one, press the **BLUE** key, then the **STORE, 1** keys. Calibration factors for other frequencies can now be made and recalled when needed, by pressing the **BLUE** key, then the **RECALL**, (corresponding register) keys.

Agilent Technologies' Test and Measurement Support, Services, and Assistance

Agilent Technologies aims to maximize the value you receive, while minimizing your risk and problems. We strive to ensure that you get the test and measurement capabilities you paid for and obtain the support you need. Our extensive support resources and services can help you choose the right Agilent products for your applications and apply them successfully. Every instrument and system we sell has a global warranty. Support is available for at least five years beyond the production life of the product. Two concepts underlie Agilent's overall support policy: "Our Promise" and "Your Advantage."

Our Promise

"Our Promise" means your Agilent test and measurement equipment will meet its advertised performance and functionality. When you are choosing new equipment, we will help you with product information, including realistic performance specifications and practical recommendations from experienced test engineers. When you use Agilent equipment, we can verify that it works properly, help with product operation, and provide basic measurement assistance for the use of specified capabilities, at no extra cost upon request. Many self-help tools are available.

Your Advantage

"Your Advantage" means that Agilent offers a wide range of additional expert test and measurement services, which you can purchase according to your unique technical and business needs. Solve problems efficiently and gain a competitive edge by contracting with us for calibration, extra-cost upgrades, out-of-warranty repairs, and on-site education and training, as well as design, system integration, project management, and other professional services. Experienced Agilent engineers and technicians worldwide can help you maximize your productivity, optimize the return on investment of your Agilent instruments and systems, and obtain dependable measurement accuracy for the life of those products.

By internet, phone, or fax, get assistance with all your test and measurement needs.

Online Assistance

www.agilent.com/find/assist

Phone or Fax

United States:

(tel) 1 800 452 4844

Canada:

(tel) 1 877 894 4414

(fax) (905) 206 4120

Europe:

(tel) (31 20) 547 2323

(fax) (31 20) 547 2390

Japan:

(tel) (81) 426 56 7832

(fax) (81) 426 56 7840

Latin America:

(tel) (305) 269 7500

(fax) (305) 269 7599

Australia:

(tel) 1 800 629 485

(fax) (61 3) 9210 5947

New Zealand:

(tel) 0 800 738 378

(fax) (64 4) 495 8950

Asia Pacific:

(tel) (852) 3197 7777

(fax) (852) 2506 9284

Product specifications and descriptions in this document subject to change without notice.

Copyright © 1985, 2000 Agilent Technologies

Printed in U.S.A. 9/00

5968-6296E

For more information visit our Web site at:

www.agilent.com/find/wireless



Agilent Technologies

Innovating the HP Way