

Keysight Technologies

Optimizing Power Product Usage to Speed Design Validation Testing

Application Note

Testing speed is critical to design validation engineers. To thoroughly evaluate today's complex systems, they must perform a variety of tests quickly to tweak and optimize a design for best performance, and also must test a new design under a variety of operating and environmental conditions to determine its limits.



Introduction

For tests of this kind, being able to quickly set up and alter a test configuration is of particular importance, although reducing test duration is also important, particularly for long and elaborate tests. Those who have been required to spend long minutes or hours with their hands in an environmental chamber set to extremes waiting for a test to complete can appreciate the importance of reducing the actual test time.

To the design validation engineer, tests per unit time is the more important part of throughput, rather than devices per unit time. The reverse would be true for the manufacturing test engineer. But both can certainly benefit from all means of reducing testing time. The only difference is which ones to emphasize.

The power instruments selected for a test, and how they are set up and used, can significantly affect test throughput. Modern power instruments (such as system power supplies and electronic loads) include features that can improve test throughput. Knowing these features, and other methods and techniques for using power products most effectively, is important for efficient testing.

This application note is for design validation engineers who need to conduct complex and/or time-consuming tests using power products. It presents methods and techniques to decrease setup time and test time. It is also useful to the manufacturing engineer, as these methods can be beneficial for manufacturing tests.

Minimize Setup Time

Reducing the time required to set up the equipment and other components required for a design validation test is the most significant way engineers can increase the number of such tests they can accomplish in a given amount of time. This reduces the amount of time required to perform different iterations of a test with varying design parameters and operating conditions. Manufacturing engineers also need to keep an eye on setup time, particularly for test procedures that require changing or complicated test configurations.

One-Box Solutions Simplify Setup

One of the easiest ways to reduce setup time is to use one-box power products. These instruments substantially reduce the amount of time required to assemble the power subsystem for a test. Many of today's system power supplies, AC sources, and electronic loads feature built-in voltage and current measurements, built-in voltage and current programmers, status readback, and service request interrupts in a single package (figure 1). This eliminates the need to assemble a power subsystem from individual pieces, which besides taking longer would result in a system with limited flexibility and uncertain performance.

One-box solutions offer many features that reduce complexity and uncertainty. These include:

- Fully specified performance. One set of specifications covers the entire instrument from GPIB input to the output.
- Ease of use. Front-panel controls or easy-to-use graphical user interfaces speed up system development. Outputs are programmed in volts, amps, and similar self documenting programming commands. System features such as status readback and electronic calibration also speed development and reduce required maintenance time.
- Reduced system complexity. With everything in one box, there is no long list of extra equipment to obtain and then stuff into a crowded equipment rack. This also eliminates external cabling and interconnections between units, greatly increasing reliability and simplifying integration.

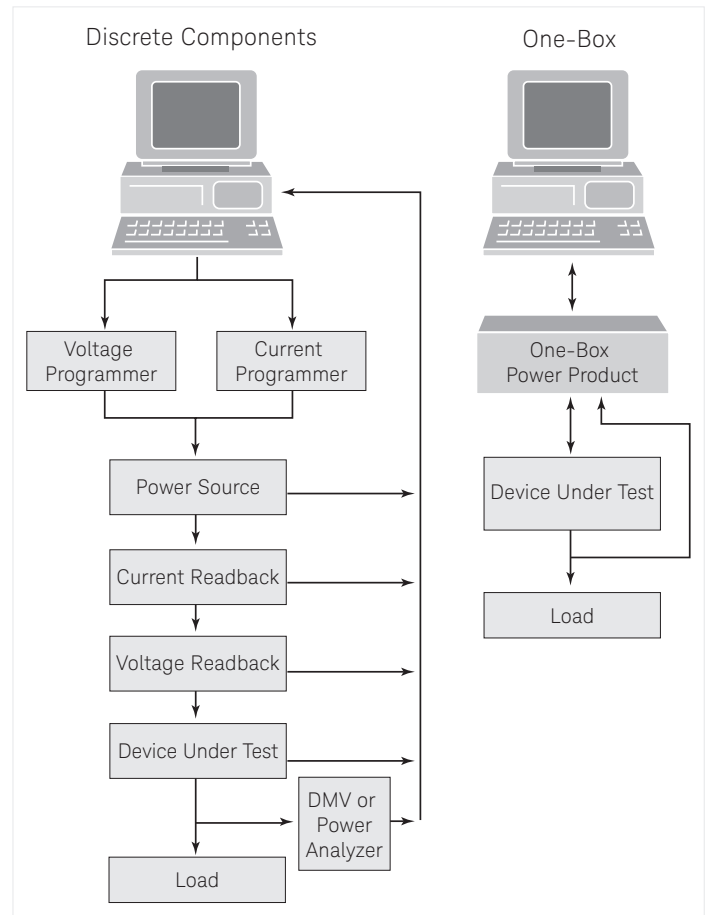

Figure 1. The one-box approach to power products eliminates or reduces the need to assemble a power subsystem from many separate components.

Minimize Setup Time (continued)

Scope Substitution

A number of power products also incorporate built-in measurement functions. This further reduces the need for additional equipment and cabling, making test setup even faster and easier.

One-box solutions have many applications that reduce setup time. For example, to adequately specify the power source for products that exhibit pulsed and dynamic current loading (such as digital cellular phones and hard drives), both the peak and DC-average current draws need to be evaluated.

To accomplish this, an oscilloscope could be used to monitor a shunt or current probe, but this approach can create problems with voltage drops, ground loops, common-mode noise, space, and calibration. A simpler and cheaper alternative is to use a power supply with built-in dynamic measurement capabilities. A capable DC source can acquire pre- and post-trigger buffer data when a user-set threshold is crossed. Figure 2 shows data measured by a DC source.

An electronic load with built-in waveform digitization can be used in place of an oscilloscope for certain measurements such as observing power supply transient behavior and noise. Using a scope is time consuming in many systems because many operating parameters must be specified during setup. For test programs that allow execution of tests in random order, a full setup for each test segment would need to be programmed, a lengthy process.

Oscilloscopes also need to acquire large amounts of data before providing any measurement results. If an oscilloscope has to be switched between power supply outputs, then even more time is needed before data is available. System throughput is improved each time the digitization capabilities of a load are used in place of the more complex functions of an oscilloscope.

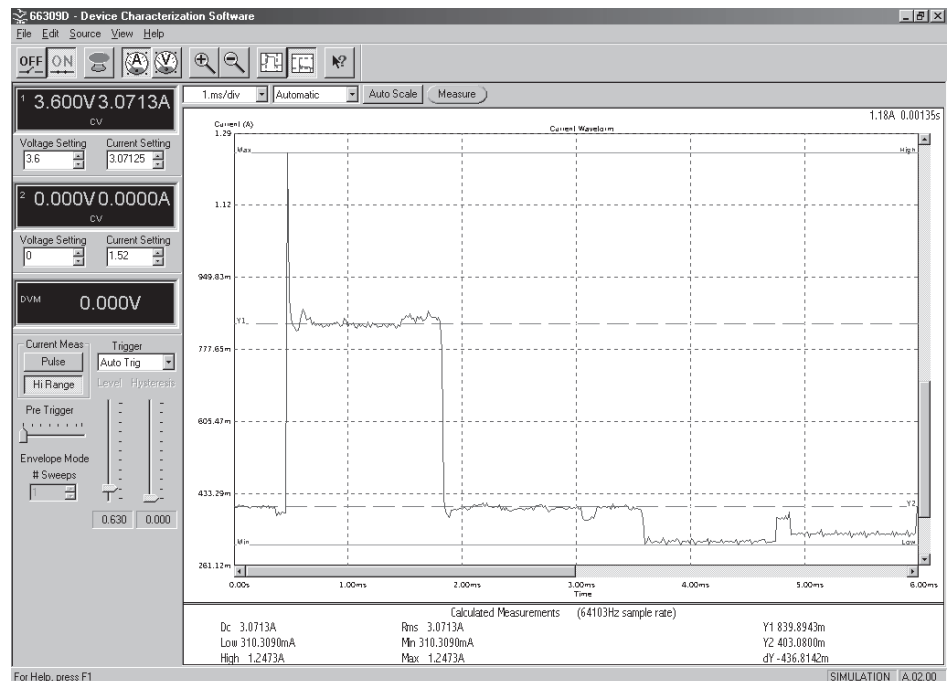

Figure 2. Characterization of pulse current loading of a digital cellular phone, captured by a DC source with built-in measurement capabilities

Minimize Setup Time (continued)

More Measurement Capabilities

Another example of using built-in measurement functions is accurately measuring DUT supply currents above 10 A, which is beyond the range of the typical DMM in ammeter mode. An external shunt and a DMM's voltage mode could be used for this measurement, but using a power source with a built-in shunt has the "one-box" advantages of fewer components to connect with less wiring complexity, simpler control, and documented error and performance characteristics. Table 1 shows the level of accuracy that can be expected with a good-quality supply.

Output Level	Typical Accuracy
Full	0.1% to 0.5%
10% of full output	0.5% to 1%
1% of full output	near 10%

Table 1. The current measurement accuracy of a typical power supply with built-in measurement capabilities, at various output current levels

While the advantages of using the power source to measure high currents are clear, the benefits of using it to measure low currents are not as obvious. A good system DMM can measure current down to the picoamp level, but DUT supply currents rarely need to be measured this low. In most cases, the toughest measurement will involve current draw by a battery-powered device in sleep mode (such as a cellular phone), where measuring 0.1 mA with reasonable accuracy is usually adequate.

A system DMM's stated accuracy (0.01% to 0.1%) doesn't include other possible error sources that can affect the measurement, such as cabling. However, the power supply accuracy figures in the table include all applicable factors, because cabling and other error sources are not needed with the built-in measurement capability.

Yet another example of reducing setup time and complexity with one-box power products is characterizing AC inrush current versus turn-on phase, which provides important design insights but can be a challenging measurement. The current digitization and peak-current measurement must be synchronized with the startup phase of the voltage.

A traditional test setup includes an AC source with programmable phase capability and an output trigger port, a digital oscilloscope, and a current probe. However, some advanced AC sources can provide built-in voltage generation, current waveform digitization, peak-current measurement, and synchronization. This enables AC inrush current characterization without cabling and synchronizing separate instruments (figure 3).

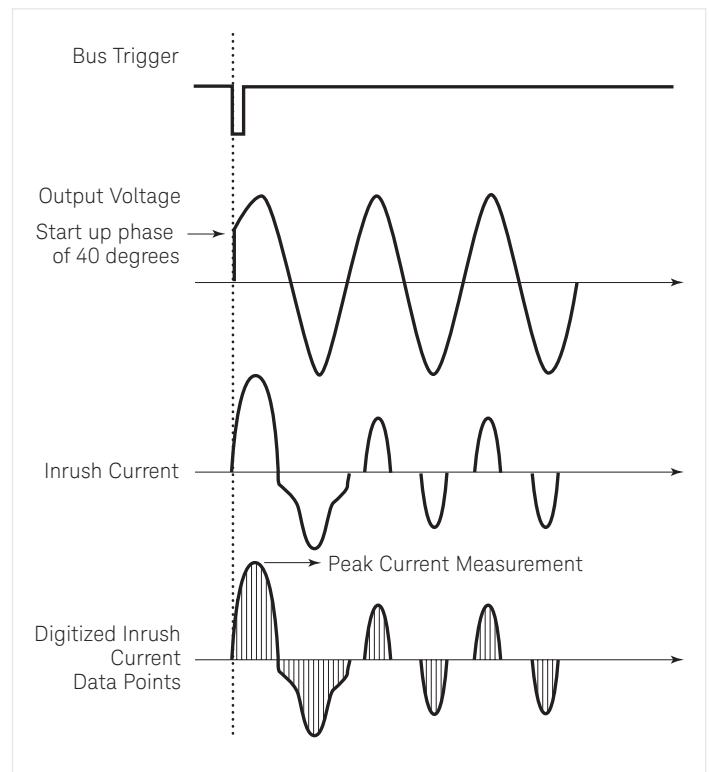

Figure 3. An AC inrush current measurement at 40° using the Keysight Technologies, Inc. 6800 series AC power source/analyzers

Minimize Setup Time (continued)

Manage Hazardous Conditions More Effectively

Modern power products may include safety features that make handling and reporting dangerous conditions easier. Having these features built in reduces the time required to plan for unexpected hazardous situations. Overcurrent and overvoltage protection can shut down the output and send interrupt requests when dangerous conditions occur. In addition, external control ports on many newer instruments make it easy to incorporate emergency system shutdowns in response to external events.

Remote disable offers a simple way to shut down a power supply to respond to a hazardous operating condition or to protect system operators. Remote inhibit (RI) is an input to a power supply that disables the output when the RI terminal is pulled low. Shorting the normally open switch turns off the supply's output (figure 4). Also shown is the discrete fault indicator (DFI) that can be used to signal an operator or other system components whenever the power supply detects a user-defined fault.

The DFI signal can be used to report almost any operating condition. For example, to generate a DFI signal from a power supply when the DUT draws excessive current, the engineer would program the current slightly higher than the maximum current the DUT is expected to draw, enable the overcurrent protection mode, and then program the power supply to generate a DFI signal when it enters constant-current mode. If the DUT current reaches the current-limit setting, the DFI output goes low, disables the power supply, and informs the operator of the overcurrent condition.

The DFI and RI signals can be daisy-chained so that if one supply detects a fault, all supplies in the system are disabled. These features simplify managing the inevitable problem conditions that arise during design validation testing.

Another factor in reducing test setup time is the command language of the test equipment. If the equipment uses a command language that is easy to program and modify, setting up each test will go much faster. Furthermore, the fewer languages the engineer must learn, the faster and easier the test configuring will go. If all the test instruments have a common command language, the engineer won't have to spend so much time paging through reference manuals learning different command sets, so the time required to program and debug the test setup will be reduced.

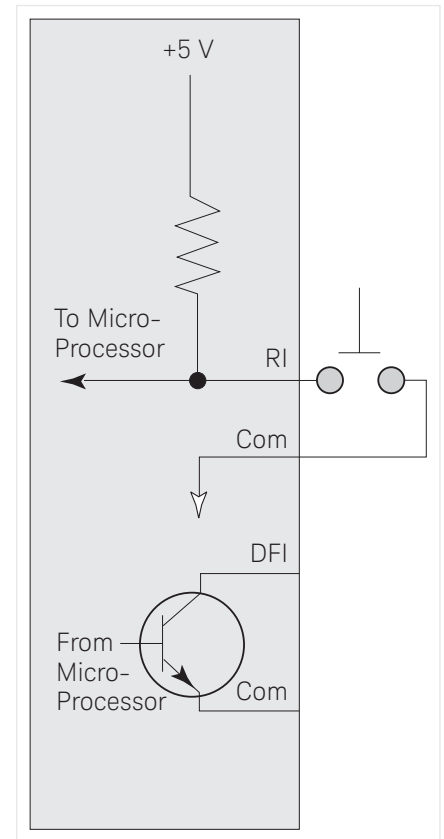

Figure 4. Schematic of remote inhibit (RI) and discrete fault indicator (DFI) functions

Reduce Test Run Time

Although the actual time required to run the tests is not always as significant to the design validation engineer as setup time, it is still worth reducing as much as is practical, especially for long or complicated tests. For the manufacturing test engineer, who must design tests that run repeatedly, shrinking the duration of tests is of course very important for improving throughput. Test run time can be reduced in all the phases of the testing process: the time required to send and execute commands to control the power subsystem, the time required for the power subsystem to actually perform its operations, and the time required for measuring and monitoring during test operation.

Reduce Command and Control Time

Reducing the time required for the power subsystem components to receive commands from the test system computer, and interpret and execute them, is an important aspect of reducing test run time.

List Mode

Power products with a feature known as list mode can store complete instrument setup states. These can be recalled with a single command, radically reducing the time required to send a long series of individual configuration steps. The longer and more complicated the test sequence, the more time list mode saves. List mode also benefits applications that require a variety of voltage levels simultaneously.

Execution of a list can be paced by triggers or paced automatically. After a list is stored in memory, a trigger is used to begin its execution. A trigger can continue to be used to execute each step in the list, or the amount of time the power instrument remains at each list step can be specified as part of the list. Lists may be stored in one of the nonvolatile memory locations to remain resident in the power instrument even after it is turned off, reducing setup time for a subsequent test even at a later time.

In a modular power system, list mode allows the downloading of a command sequence to each power system module during system setup. The module interprets the commands and then stores them internally, ready to execute. The command sequence may be accessed with a single trigger command from the test system computer, and may be accessed repeatedly during testing. When the sequence is initiated, the module runs at maximum speed because the GPIB bus transfer and load command processing steps are eliminated.

Reduce Test Run Time (continued)

A modular power system also allows triggering via the backplane in conjunction with list mode to add even more capability and flexibility. Various modules can be preconfigured with a command list to output particular voltage levels. With a single trigger command to launch a programming sequence, module-to-module backplane triggering can initiate list-mode setups in subsequent modules. Figure 5a shows a block diagram of such a setup, and figure 5b shows the resulting power-output curves.

Using lists and triggers saves time in several ways:

- The computer sends the list sequence only once.
- The module interprets the commands only once.
- The module can automatically step through the list without computer intervention.

Use the GPIB Interface More Efficiently

Another way to save on the amount of time required to transfer commands from the test system computer to the power subsystem is to use multiple single-output power supplies rather than one multiple-output supply. This allows overlap of GPIB operations to the multiple supplies, and avoids the delays resulting from sequential command processing in a multiple-output supply.

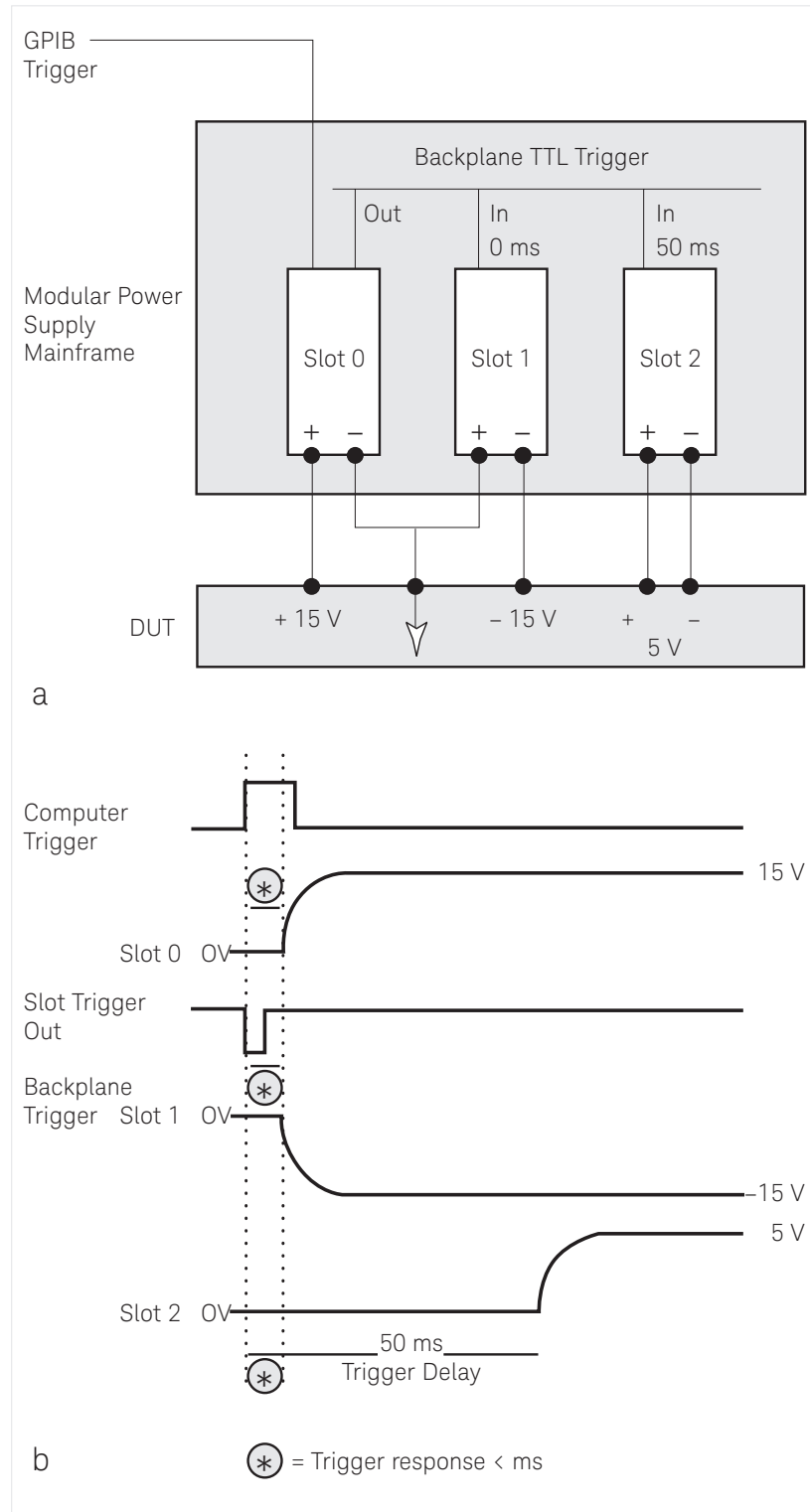

Figure 5. Backplane triggering in conjunction with list mode can be used to launch outputs at different times. (a) A three-module setup in which slots 0 and 1 provide power simultaneously and slot 2 is set to start 50 ms later. (b) The set of power curves generated by this setup shows the delayed output of slot 2.

Reduce Test Run Time (continued)

In a multiple-output supply, commands controlling the various outputs are processed sequentially, one output at a time. With a multiple-supply setup, however, one supply can be processing a command while the next is receiving one, and so on.

This technique is most beneficial when making queries from the supplies. With a multiple-output supply, the measure command must be sent and the response retrieved from a particular output before querying the next output. Because the measurements must be made one after the other, a query can take two measurement cycles to complete.

With multiple instruments, however, a command can be sent to each of the supplies to start the measurement, and then the responses can be retrieved. Because the measurements are overlapped, only one measurement cycle is required. Although the time savings for an individual setup or query operation can be modest, for complex repetitive tests the cumulative time savings can have a dramatic impact on overall system throughput.

Use the Available Features

Judicious use of the available commands and power-instrument features is also important for reducing test time. The “Operation Complete” command can save significant test time, especially for tests in which certain operations take a highly variable amount of time to complete. The traditional way to handle this type of condition is to determine the worst-case amount of time to complete an operation and establish that as the wait time for that step for all test runs. Of course this would waste a significant amount of time during runs when the operation in question completes quickly.

With the Operation Complete command, the test control software is informed after the variable-length operation has completed, allowing the test to proceed immediately rather than unnecessarily waiting the worst-case amount of time for each operation.

Another feature that can reduce test time is binary transfer mode. Transferring large data arrays such as measurement waveforms is faster in binary than ASCII format for instruments that support it. Binary transmission requires fewer bytes, reducing transfer time by a factor of two or more.

Optimize the Execution Sequence

A final method of saving time in the process of controlling the power subsystem is to order the execution sequence to minimize run time. A first step in optimizing the execution sequence is to order the test steps such that at the end of one step, the DUT is in the desired state to begin the next step. For example, if the DUT needs to be turned off for the start of a test step, the preceding step should be one that leaves it off. If a particular step requires that the DUT is warmed up, this step should be placed later in the sequence, perhaps with a system timer to guarantee that it has been on long enough. This technique is not always feasible but can yield big improvements.

Another method of optimizing the execution sequence to speed test run time involves overlapping wait periods. A typical test sequence prior to optimization might be:

1. Apply a load to the DUT or set up its programmed state.
2. Wait for DUT output to settle.
3. Connect relays to engage measurement equipment.
4. Wait for relays to close.
5. Set up measurement instrument.

Reduce Test Run Time (continued)

6. Wait for setup to complete.
7. Initiate measurement.
8. Wait for measurement to complete.
9. Disconnect relays.
10. Turn off power source.
11. Wait for DUT output to settle.

Most of these steps involve a wait while the action completes. In addition, most DUTs need time to stabilize after power is applied or a load condition has changed. By separating the programming and wait states, the test can be rearranged so that one instrument is being programmed while another is completing its step. The above test sequence could be rearranged as follows:

1. Apply load to the DUT.
2. Connect relays to engage measurement equipment.
3. Set up measurement instrument.
4. Wait for relays to close, measurement instrument to settle, and DUT output to settle.
5. Initiate measurement.
6. Wait for measurement to complete.
7. Disconnect relays.
8. Turn off power source.
9. Wait for DUT output to settle.

Overlapping the wait periods minimizes overall delays. While the DUT is settling, the test program is busy programming the relays and setting up the measurement instruments. A common or global timer can be used to implement an overlapped wait. Each programming routine that sets up an instrument or DUT can tell a global timer how long each action will take; this identifies which action requires the longest wait. Then when a measurement or other test requires that the previous commands be completed, a call to a single wait function will wait until the global timer expires before continuing, as follows:

1. Apply load to the DUT.
2. Connect relays to engage measurement equipment.
3. Set up measurement instrument.
4. Wait for global timer.
5. Initiate measurement.
6. Wait for global timer.
7. Disconnect relays.
8. Turn off power source.
9. Wait for DUT output to settle.

With this approach, the test does not have to wait any more than is necessary for instrument setup, and the programming is also simpler.

Using a one-box solution will simplify many of these steps without requiring execution sequence optimization. Also, for design validation testing, the time saved during the test must be weighed against the time required to figure out the optimal sequence. However, for tests with long wait periods, and for manufacturing tests, this technique can yield throughput benefits.

Reduce Operation and Output Time

Many power products have features that can help reduce the time required for them to operate. Some of these features function automatically, and some must be activated by appropriate programming or special commands.

Reduce Test Run Time (continued)

Change Output Voltage Quickly

Using a power supply with a feature called downprogramming can significantly reduce test time, particularly when multiple voltage-level settings are needed. Without downprogramming, the capacitor in the supply's output filter (or any load capacitance) can take seconds or even minutes to discharge when the output voltage level is reduced. The lighter the load, the longer it takes.

Downprogramming uses an active circuit to force the output down to the new level within a matter of milliseconds in most cases. This circuit functions automatically whenever the set voltage level is below the present output level. Execution sequence is important with power supplies that have the downprogramming feature. Because programming up is generally faster than programming down, multiple tests should be sequenced such that each consecutive test is at the same or higher voltage level than the previous test.

Another technique for reducing test time is to program the output voltage up or down rather than using the Output On or Output Off commands. Setting the output voltage to zero volts takes less time than the Output Off command, and simply setting the voltage back up to the desired voltage takes less time than the longer Output On command.

When programming voltage up, it is important for the output to remain in constant-voltage (CV) mode for the duration of the test by staying below the user-established current limit. If the output reaches the current limit, it will enter constant-current (CC) mode. Then output voltage will not rise as quickly and will take longer to reach the desired value, slowing down the entire test. During a transition of the output voltage from a lower value to a higher value, the engineer must establish the current-limit setting (also known as the CC setting) high enough to provide charging current to the DUT, the output capacitor inside the power supply, and also to any external capacitor.

Change Loads Quickly

When simulating real-life loading conditions, controlling the slew rate of an electronic load may be necessary. For example, a controlled slew rate might be required to simulate inrush current, or a slow slew rate might be needed to keep a power supply stable and reduce ringing. Using different slew rates for transient tests can also help identify the loading rate that causes instability. A programmable slew rate enables engineers to change the slew rate of an electronic load to accommodate such requirements. However, a slower slew rate should only be used when necessary, as it will decrease throughput.

If the slew rate of an electronic load can be controlled separately for rising and falling transitions, the engineer can slow down only the transition necessary for a particular test, while keeping the other transition at maximum speed. Independently controllable slew rates for constant-current, constant-voltage, and constant-resistance modes allow even more flexibility.

Fast Response Prevents Shutdowns

A power supply with fast response combined with remote voltage sensing is important for increasing throughput of certain tests, particularly those of mobile wireless communications devices, which characteristically have a transmit burst current drain. The combination of this pulsed current drain and the impedance of wiring to the test fixture makes it difficult to maintain a stable DC voltage at the DUT when testing these devices. A significant transient voltage drop can easily activate the DUT's low-voltage shutdown circuit and disrupt the test, impairing throughput.

Reduce Test Run Time (continued)

The transient voltage response specification on typical power supplies is not adequate to ensure proper performance in this application. It specifies the performance directly at the power supply output terminals operating in local voltage sense mode. It does not consider the wiring voltage drop that the power supply is attempting to compensate for when operating in remote voltage sense mode. Moreover, most power supplies do not have sufficient speed to match the fast rise and fall times of the DUT transmit burst current. As a result, the actual transient voltage drop may be significant at the DUT even when the power supply is operating in remote voltage sense mode.

A suitably fast-responding power supply can provide an order-of-magnitude reduction of the transient voltage drop. The difference in transient voltage drop between a standard DC source and a fast-responding DC source is shown in figure 6.

Charge Batteries Faster

If charging batteries is part of a test, considerable time can be saved by using pulse charging rather than constant current. Using a power supply in constant current mode is a simple way to recharge batteries, and it also achieves 100 percent charge levels. However, this method is slow, up to 14 to 16 hours, because the charging current is only a fraction of the battery's amp-hour rating.

Pulse charging, also called transient mode, reduces the charging time, yet still charges the battery to over 90 percent capacity. The setup for this method is shown in figure 7. The electronic load acts as a switch, providing the current pulses.

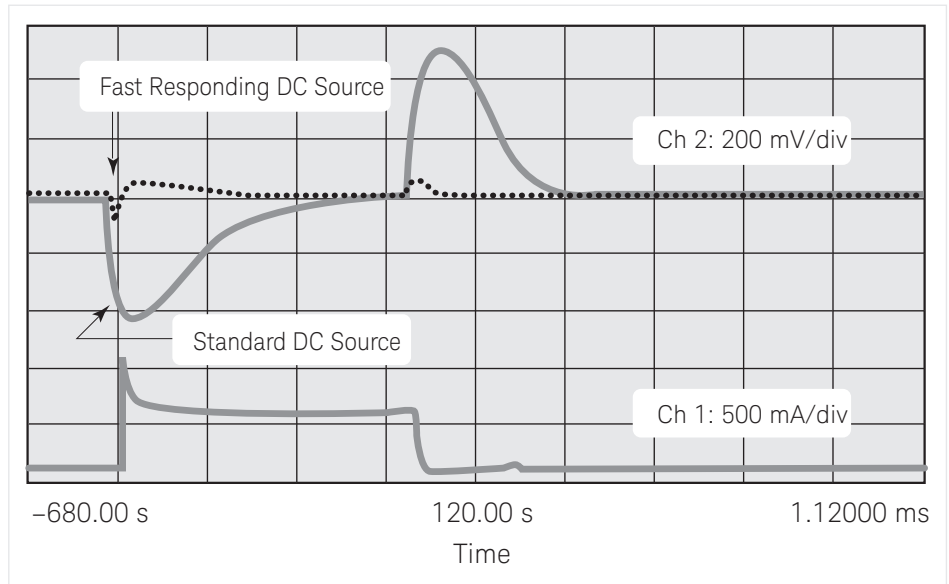

Figure 6. The difference in transient voltage drop between a standard DC source and a fast-responding DC source

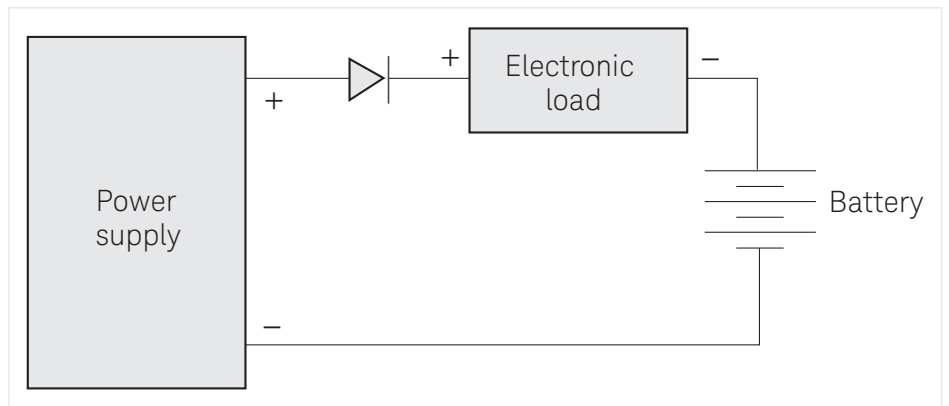

Figure 7. The setup for pulse charging using an electronic load as a switch

Reduce Test Run Time (continued)

Reduce Measurement and Monitoring Time

Another area for improving run-time throughput is in the measuring and monitoring of the operation of the DUT and power instruments. The measurement features built into many power supplies and loads can help reduce both time and complexity in automated tests. Built-in measurement features enable measuring a supply's output voltage and current, and a load's input voltage and current.

A good example is testing a DC-to-DC converter with four outputs. To fully test the device, the input voltage to the converter and each of the four output voltages need to be measured. If a single DMM is used to measure the voltages, a multiplexer is needed to sequence through the measurements, as shown in figure 8a. This arrangement is time consuming to set up, and also slow to run, as the test program must wait for the multiplexer's switches to move and settle for each measurement. The DMM's measurement time for each output would be even greater than that required for the multiplexer, further adding to the total measurement time.

The DC source and loads needed to test the converter can perform all measurements in parallel, as shown in figure 8b. Remote sensing is used in this configuration to provide regulation and measurement at the DUT rather than at the loads or the DC source. This approach will also work if current measurements are needed, eliminating the need for current shunts as well.

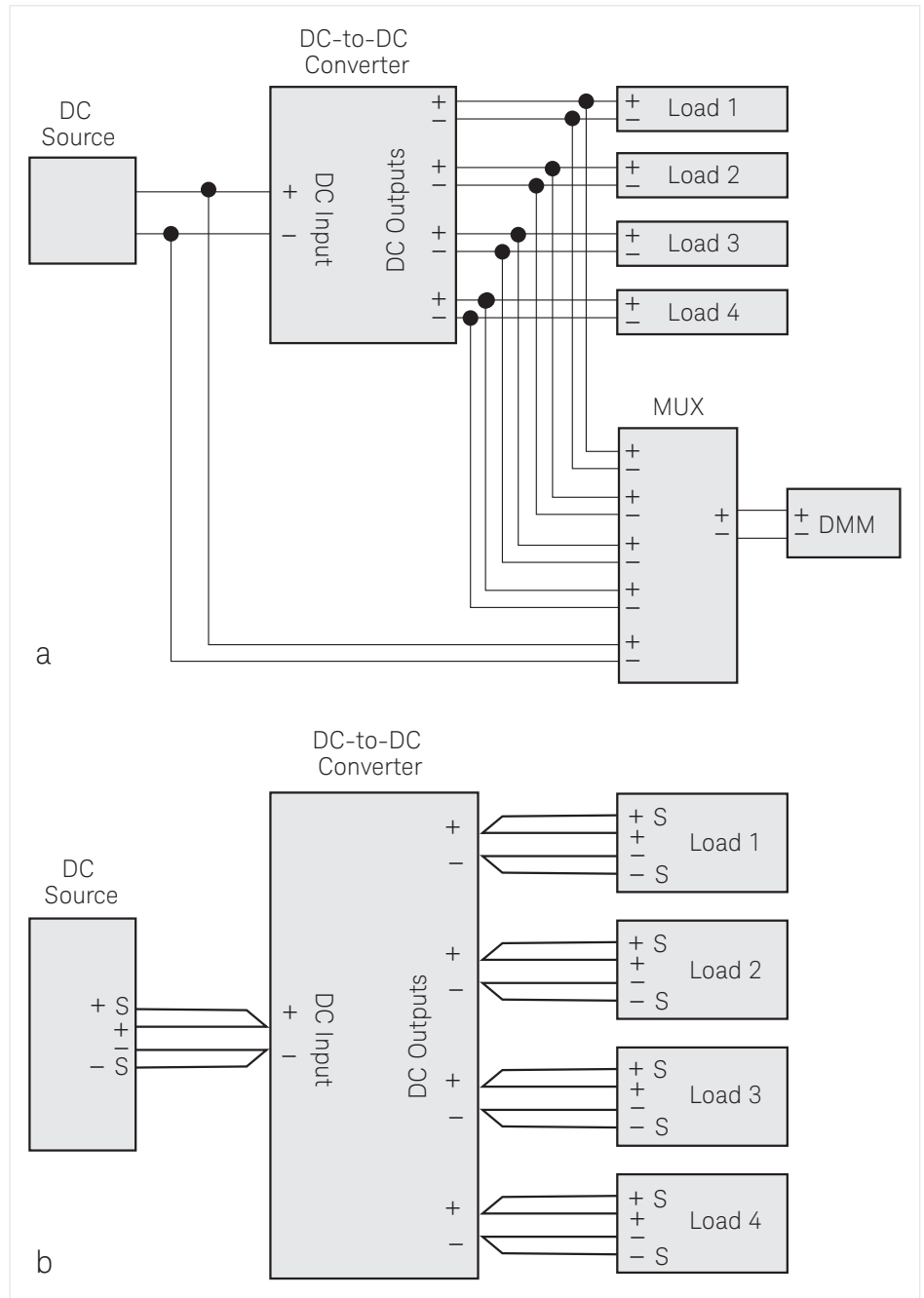

Figure 8. Testing a DC-to-DC converter with four outputs: (a) Using a single DMM requires a complex multiplexing scheme that can result in significant delays. (b) Using a DC power source and electronic loads with built-in measurement capabilities eliminates the need for a DMM and multiplexer, and can significantly increase test speed.

Reduce Test Run Time (continued)

Using this built-in measurement system eliminates (or greatly reduces) the need for the multiplexer, voltmeter, associated cabling, and current shunts. Eliminating these hardware items saves run time as well as setup time in numerous ways:

- Program lines associated with the multiplexer are eliminated.
- GPIB bus transactions to control the multiplexer are eliminated.
- The time for the multiplexer to decode the commands is eliminated.
- The time for the multiplexer's switches to settle on each new setting is eliminated.

For tests that require both voltage and current measurements, some power products allow these measurements to be made simultaneously with multiple internal A/D converters. It is important to use the correct commands to save time with this capability. A measure command initiates both measurements simultaneously, but only one parameter is immediately read back. The other should be retrieved with a special retrieval command, which does not initiate another measurement (A/D conversion process) that would take more time.

Further time can be saved by using available measurement buffers to store multiple measurements. Samples for more than one measurement can be concatenated in the buffer and transferred to the test system computer as an array in a single operation, saving interface time. The computer's program can then extract the various measurements from the array.

Control Integration Time to Improve Speed and Accuracy

Being able to precisely set the integration time when measuring the DC values of pulsed current drains optimizes test throughput and accuracy. An example of pulsed current drain is shown in figure 9. When the measurement integration time is precisely set to an integral multiple of the pulse period, the measurement accuracy is predominantly the specified DC accuracy of the test equipment. However, when there is even a small mismatch between the pulse period and integration time, significant error becomes apparent. This mismatch causes either a part of a pulse to be missed or an additional part of another pulse to be captured in the integration.

As an example, using an integration time that is 10 percent too long (4.13 ms instead of 3.75 ms) on the signal in figure 9 will produce about 45 percent error when a second pulse is captured.

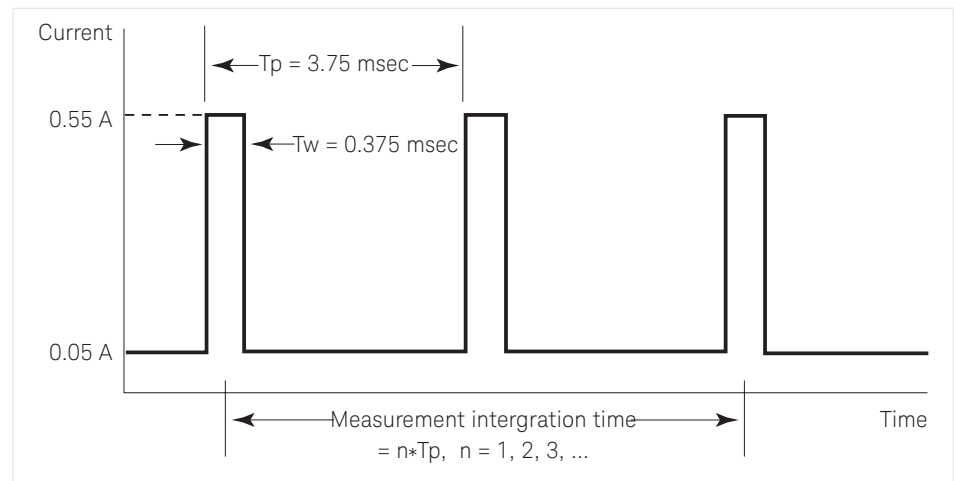

Figure 9. Setting measurement integration time for a pulsed signal

Reduce Test Run Time (continued)

The error decreases with longer integration time and number of pulses averaged. A tenfold-longer integration time will have one-tenth the error. To reduce this mismatch error, integration time must be made longer. In other words, the accuracy is improved at the expense of reduced test system throughput.

If specialized test equipment with highly accurate integration time setting is used for these measurements, the integration time can be shortened significantly without sacrificing accuracy.

Status Monitoring

Because modern system power supplies and loads have complex capabilities above their traditional functions, it is important to know the internal status of a power instrument during test operation, and what actions it has taken in response to changing input signals and other factors.

For example, a common monitoring task is checking for when a supply has entered constantcurrent mode (in which the supply will adjust its voltage to maintain a specified current level as load conditions change). This can happen when a logic device fails, for instance, resulting in sharply higher current draws by the DUT. Failing to respond to the situation could cause extensive damage to the load or other unsafe conditions.

This situation could be monitored by continually reading the supply's status via GPIB, checking for a change in the CC bit. However, this is slow and time consuming for the computer. A faster way is for the supply to be set up so that a bit gets set in its serial poll register whenever CC mode is entered. Performing a serial poll is a much faster GPIB operation, so the process wastes less time with each check. If the programming environment supports interrupts via GPIB service requests (SRQs), the polling process can be eliminated by setting up the source to generate an SRQ whenever it enters CC mode.

Status-register setups vary from one instrument to another, and have evolved to offer powerful monitoring and response capabilities. Many supplies offer registers that show operating modes and conditions as standard events (normal operating conditions) and questionable events. Questionable events include overvoltage, overcurrent, and overtemperature conditions, as well as transitions into unregulated states, such as when the supply is in neither constantcurrent nor constant-voltage mode. All of these conditions set bits in the status register and can be used to generate SRQs.

A final technique for minimizing measurement time is to customize the number of samples taken for a test so that the minimum are taken to meet the needs of the test application. Taking large numbers of samples increases accuracy and noise rejection, but the tradeoff is increased measurement time. With a power instrument that allows the number of samples in a measurement to be specified, measurement speed can be optimized relative to the measurement performance required by the application.

The Basics Are Still Important

Even with all the specialized features available on modern power instruments that improve throughput, some basic principles still apply. For one thing, processing speed remains important: A power instrument that processes commands faster will have greater throughput than a slower one.

Having accurate power instruments improves throughput as well as precision and resolution. If a power source is not accurate or stable enough, its output levels must be continually verified with a DMM, possibly with a program loop, to keep the voltages at or near expected values. Temperature drift, sudden load changes, and insufficient resolution are just some of the factors that can cause trouble. With a more accurate supply, the extra time, complexity, and expense required for frequent verification can be avoided.

Finally, having reliable instruments is critical to maintain throughput for the design validation engineer as well as for a manufacturing facility. A test system experiencing downtime has zero throughput. Instruments that produce or dissipate large amounts of power are especially susceptible to problems, so reliability in power products is particularly important.

One-box power subsystem solutions have reliability as well as speed advantages. Without the extra shunts, multiplexers, DMMs, and other elements, there are fewer discrete elements, reducing the chance of errors and instability. Moving parts such as relays tend to be among the most unreliable. Also, simpler test systems have fewer problems due to their lower complexity, and the simpler a system is, the quicker it is to troubleshoot problems when they do occur.

Summary

Power instruments now incorporate many features that can improve test throughput. Features that reduce test setup time are particularly important in the design validation process, as they can increase the number of different tests that can be accomplished in a given time period. One-box power products with built-in measurement capabilities and multiple channels are examples of this.

Features that reduce test run time are particularly important for manufacturing testing, as they increase the number of devices that can be run through a test configuration in a given time period. These include capabilities such as downprogramming and list mode.

However, reducing both setup time and run time is beneficial in both the design validation and manufacturing test environments. Selecting capable power instruments and using them effectively is important for improving test throughput.

www.keysight.com/find/assist

This document was formerly known as application note number 1434.



This information is subject to change without notice.
© Keysight Technologies, 2002 - 2017
Published in USA, December 5, 2017
5988-8340EN
www.keysight.com