

Keysight Technologies

# Recognizing and Reducing Data Acquisition Switching Transients

Application Note



## Introduction

If you make sequential measurements with a data acquisition/switch unit or data logger, you could be having problems and not even realize it. Transients in your switching system can wreak havoc with your measurement results, cause crosstalk between channels or damage your relays.

This application note is intended to help you recognize, understand and resolve problems associated with switching transients. We will use the Keysight Technologies, Inc. 34970A data acquisition/switch unit in our examples, but the principles we discuss are applicable to data acquisition/switch units and switch cards from any test-equipment vendor.

## Symptoms of Transients in Switching Systems

How do you know if you are experiencing transient voltage or current in your switching system?

Here are some common symptoms:

- Digital logic connected to the switch card resets or is erratic
- Voltage from previous channel appears unexpectedly as an output on the next channel
- Your data acquisition/switch system resets or hangs
- Voltages across the relay/switch are twice the applied voltage
- The life of your relay/switch is unexpectedly low
- Sensitive devices in the DUT (device under test) are damaged

## What causes transients?

When you are using a 34970A data acquisition/switch unit with a switch card such as the 34901A, low impedance sources can produce large and fast current transients. These high-current transients may appear to be caused by simultaneous contact closure, but they are actually caused by measurement circuitry stray capacitances. The current transients may cause problems with adjacent channels, create transients in the ground circuit that upset digital logic connected to the device under test, or in some cases, cause the 34970A to reset or hang.

To understand these transients, we must consider the stray capacitance found in measurement circuitry. Figure 1 shows connections that can cause the above-described symptoms. Figure 1 shows the stray capacitances C1 (~120 pF) and C2 (~70 pF) associated with the inputs to the DMM to ground. Channel 1 is connected to measure a low-value resistor that is connected to ground. Channel 2 is connected to measure the current of a load connected to a 25 Vdc power supply. The sense resistor is 0.1 ohm. Channel 3 represents a resistor measurement.

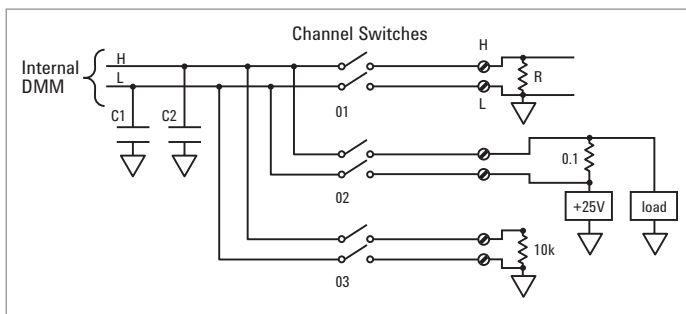

Figure 1: C1, C2 represent stray capacitance that can create transient currents and voltages.

## Example 1

Now we will take a look at what happens when we scan through channel 1, channel 2, and channel 3.

### Channel 1 closes

When channel 1 closes, the voltages on capacitors C1, C2 are discharged and the voltages across both capacitors rapidly approach zero.

### Channel 2 closes

When channel 2 closes after channel 1 opens, the 25 Vdc from the power supply quickly charges both capacitors. The series resistance of the circuit is the output resistance of the power supply (<0.1 ohm), the shunt resistor (for C2 only), the resistance of the traces on the PC board, the relay contact resistance (<0.1 ohm) and finally the ground path back to the power supply. This total resistance will be less than 1 ohm. The initial surge current will be more than 25 amps through each contact. These large, fast transient currents cause havoc with digital circuits. Power supply voltages greater than 100 volts may create transients that interfere with proper operation of the data acquisition system.

The large transient currents create arcing across the relay contacts as they close, which causes movement of metal from one relay contact to the other, or other deterioration of the contact surface, and reduces the life of the relay. These transients are of short duration and are difficult to measure.

After channel 2 relays open, C1, C2 are both charged to approximately +25 volts.

### Channel 3 closes

When channel 3 closes, C1 will discharge a large current pulse through the ground circuit (creating large currents similar to those that occurred when channel 2 closed). Channel 3 Lo relay will likely wear out faster than channel 3 Hi. The 25 volts on C2 will initially be seen across the 10k ohm resistor. The voltage will be across the 10k ohm resistor as a transient until it is discharged. You will see it as an output from the high to low terminals of the channel, and you may even interpret it as a failure of channel 2. The symptom is similar to having channel 3 close before channel 2 opens. Actually, channel 2 does open before channel 3 closes.

## Example 2

An unexpected voltage also manifests itself when the source is floating (very high impedance to ground, see figure 2). After channel 1 closes, C1 and C2 are in series and will charge such that 25 V is present between points A and B. When channel 1 opens the +25 V at point A referenced to B remains. When channel 2 closes, one of the contacts will close before the other. Assume the lower of the two contacts closes first. Now C will be -25 V referenced to B and the voltage across the upper channel 2 contact will be 50 V. In this case the sum of both voltage sources must be less than the rating of the relay.

A severe case occurs when you measure AC line voltage on two successive channels; the voltage across the relay of the second channel may be twice the peak voltage and create very large currents and arcing.

## How to solve transient problems

To reduce the current transients that create problems in the digital circuits associated with the measurement and reduce the life of the relay contacts, place a resistor of 100 ohms in series with the Hi and/or Lo channel terminal that is connected to a low impedance source or to ground. The current limit resistor will not deteriorate voltage measurement but will limit the peak current. Placing the current sense resistor at the low side of the power supply will also avoid the high voltages.

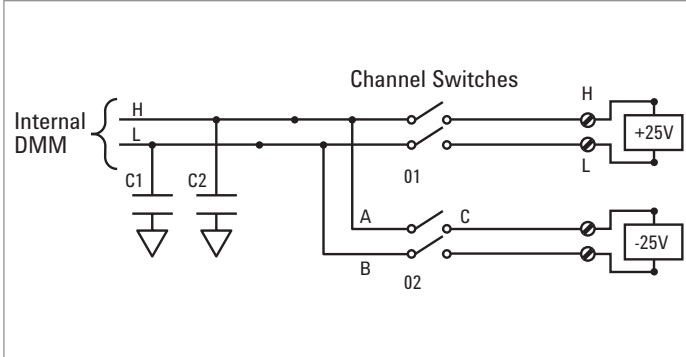

Figure 2: Floating sources can create current and voltage transients in adjacent channels.

You can prevent the voltage of one channel transferred to the subsequent channel by setting up an intermediate channel that has the Lo and Hi tied to ground through a 100 ohm resistor to discharge C1 and C2. This channel may be activated after switching voltages higher than can be tolerated by a subsequent measurement.

## Conclusion

The switching transient problems discussed in this application note are common. Fortunately, they can be reduced using the techniques described in this application note, to eliminate problems.

## Glossary

Transient — transition behavior until a steady state is achieved, may be initiated by a contact closure

## Related Keysight Literature

Data sheet — 34970A Data Acquisition/Switch Unit, pub. no. 5965-5290EN



**myKeysight**

[www.keysight.com/find/mykeysight](http://www.keysight.com/find/mykeysight)

A personalized view into the information most relevant to you.

**Keysight Channel Partners**

[www.keysight.com/find/channelpartners](http://www.keysight.com/find/channelpartners)

Get the best of both worlds: Keysight's measurement expertise and product breadth, combined with channel partner convenience.

This document is formerly known as Application Note 1444.

For more information on Keysight Technologies' products, applications or services, please contact your local Keysight office. The complete list is available at: [www.keysight.com/find/contactus](http://www.keysight.com/find/contactus)

**Americas**

Canada	(877) 894 4414
Brazil	55 11 3351 7010
Mexico	001 800 254 2440
United States	(800) 829 4444

**Asia Pacific**

Australia	1 800 629 485
China	800 810 0189
Hong Kong	800 938 693
India	1 800 112 929
Japan	0120 (421) 345
Korea	080 769 0800
Malaysia	1 800 888 848
Singapore	1 800 375 8100
Taiwan	0800 047 866
Other AP Countries	(65) 6375 8100

**Europe & Middle East**

Austria	0800 001122
Belgium	0800 58580
Finland	0800 523252
France	0805 980333
Germany	0800 6270999
Ireland	1800 832700
Israel	1 809 343051
Italy	800 599100
Luxembourg	+32 800 58580
Netherlands	0800 0233200
Russia	8800 5009286
Spain	800 000154
Sweden	0200 882255
Switzerland	0800 805353
	Opt. 1 (DE)
	Opt. 2 (FR)
	Opt. 3 (IT)
United Kingdom	0800 0260637

For other unlisted countries:  
[www.keysight.com/find/contactus](http://www.keysight.com/find/contactus)  
(BP-09-23-14)

