

# Keysight N7786B Polarization Synthesizer

Data Sheet



## Introduction

The Keysight Technologies N7786B contains a high-speed lithium-niobate based polarization controller and a polarization analyzer plus a microcontroller-based driving circuitry.

### **This unit can operate in various modes:**

**As a polarization stabilizer**, it provides a stable output state of polarization (SOP) even with fluctuations and drifts of the input SOP. The stabilized output signal is guided in a standard single-mode fiber (SMF). The output SOP can be defined in the following ways:

- Set-and-forget: When the front button is pushed, the current SOP is stored and maintained, even if polarization changes occur on the instrument input.
- Defined stokes: The target output SOP can be defined by the user using the Stokes parameters.
- As a synchronous scrambler, the device switches the SOP of the output signal in a random (pseudo) way with a cycling speed of up to 100 KSOPs/s.

SOP switching occurs within a few microseconds. An electrical trigger input can be used to synchronize the scrambler with external events.

As an **SOP switch**, the N7786B cycles through a sequence of SOPs with a speed of more than 40 KHz, which corresponds to a cycle time of less than 25 microseconds. The sequence of SOPs can easily be defined by the user using Stokes coefficients.

As a traditional **scrambler**, the N7786B varies the output SOP in a random way.

Full coverage of the Poincaré Sphere is achieved within a few ms.

As a **polarization analyzer**, the instrument provides truly high-speed capabilities: More than 500K samples can be taken with a sample rate of up to 1 Megasample per second.

As **fast-switching polarization controller** for single-sweep wavelength dependent PDL measurements in combination with the N7700A PDL software and an Keysight tunable laser and power meter. See the N7700A literature for details.

All above-mentioned applications of the N7786B are supported by Keysight PC software that comes with this instrument.

Various instrument drivers and connectivity to external applications are provided through a DLL interface. Examples are included.

## Key Benefits

- Comprehensive polarization stabilization/control
- Fast switching capabilities
- Enables single-sweep spectral PDL measurements with N7700A PDL software engine.
- Reset-free/endless operation
- Covers entire range from 1.3 μm window up to the L-band
- Standalone operation
- Robust, no moving parts

## Applications

- Swept-wavelength PDL measurements with tunable laser and N7700A software
- Transmission system test: Polarization sensitivity analysis on link/transmission quality
- Recirculating loop experiments: Loop-synchronous polarization scrambling
- Interferometry: Polarization stabilization to maximize contrast ratio
- Polarization analysis

## Keysight N7786B Instrument Setup and Application Examples

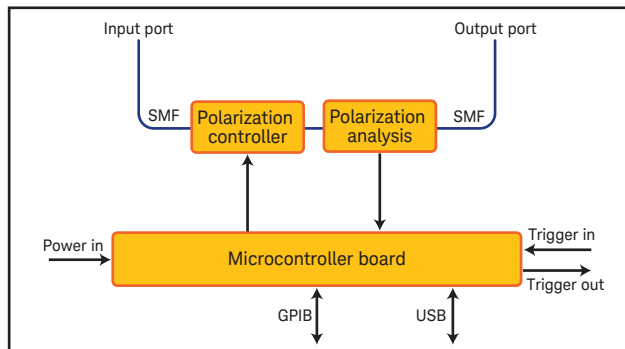

Figure 2. Instrument setup

The instrument setup is shown in Figure 2. A DSP-based electronics controls the polarization analyzer as well as the polarization controller. The SOP can be stabilized by means of a closed-loop operation of the DSP.

## Application examples

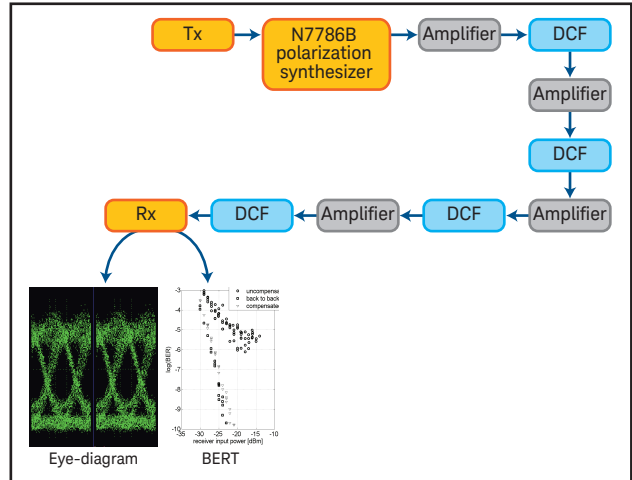

Figure 3. Transmission experiments

The transmission quality of links is known to depend on the state of polarization (SOP) of the launching signal. The N7786B is well suited to launch the modulated signal with predefined SOPs into the link. This allows probing for a range of SOPs on the Poincaré sphere to get information about particular polarization issues of a link.

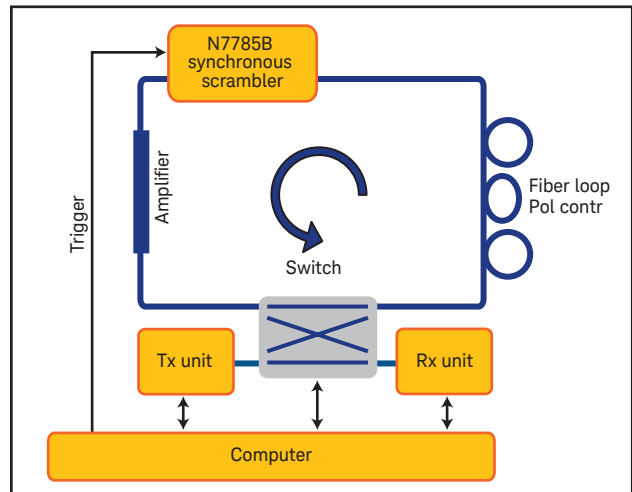

Figure 4. Recirculating loop.

The results obtained in re-circulating loop experiments depend heavily on the PMD and PDL properties of the loop. Loop synchronous polarization scrambling schemes have proven to be necessary for generating results comparable to deployed systems. The N7786B is ideally suited to provide the synchronous scrambling capability in such experiments.

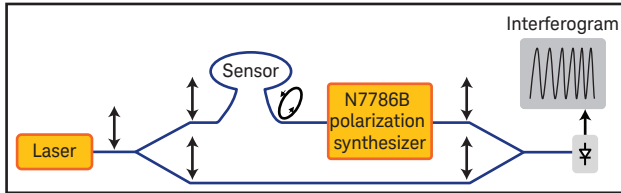

Figure 5. Interferometry/coherent detection

Fiber-optic-based interferometers or coherent receiver schemes need polarization stabilization in order to avoid fading problems of the interference signal. These fading effects are caused by orthogonally polarized fractions of the light. The N7786B allows elimination of such effects by alignment of the signal polarization.

## Configuration for swept-wavelength IL and PDL measurements

The N7786B can be combined with the N7700A IL/PDL software package to measure polarization dependent loss and insertion loss spectra on one or multiple channels. The fast switching enables a unique single-sweep Mueller Matrix method that reduces measurement time and is very robust against environmental disturbance like fiber movement and temperature drift, while maintaining high IL dynamic range, wavelength accuracy and freedom from bandwidth-limited distortions. This setup combines a continuously-swept tunable laser with the fast-switching N7786B polarization synthesizer and one or more multi-port power meter instruments.

In addition to the measured IL and PDL traces, the Mueller Matrix 1st-row data can be exported and analyzed to provide the polarization resolved IL traces for the device axes (TE/TM).



Figure 6. A very compact configuration for the IL/PDL Engine, to measure 8 channel devices in the C and L band

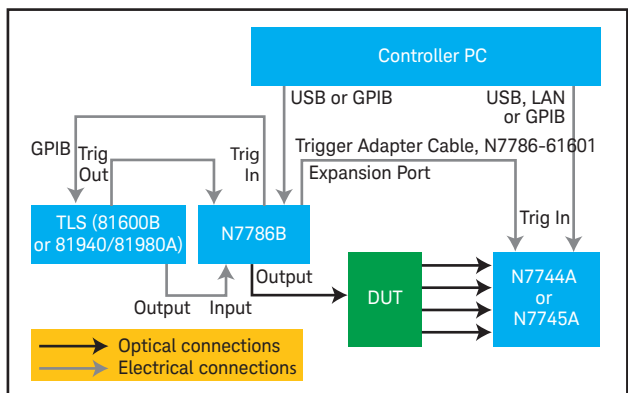

Figure 7. Schematic Setup for Single-Sweep IL and PDL measurements

**Specifications <sup>1</sup> N7786B Polarization Synthesizer**

<b>Wavelength</b>		
Specification wavelength range		1270 to 1375 nm
	Opt 400, O/C/L-Band	1460 to 1620 nm
	Opt 500, C/L-Band	1460 to 1620 nm
Operating wavelength range <sup>2</sup>	1260 to 1640 nm	
<b>Polarization control and stabilization</b>		
SOP switching time (non-deterministic)	< 10 $\mu$ s	
SOP cycling time <sup>6</sup>	< 25 $\mu$ s	
Remaining SOP error after deterministic SOP setting (typical) <sup>7</sup>	< 3° at input SOP movement rate of 1.2 rad/s	
	< 6.5° at input SOP movement rate of 40 rad/s	
<b>Polarization analysis</b>		
SOP uncertainty (typical) <sup>3,4</sup>	1,5°	
DOP uncertainty <sup>3</sup>	$\pm$ 2,0%	
DOP uncertainty after user <sup>3,5</sup> calibration (typical)	$\pm$ 0,5%	
<b>Optical power measurement</b>		
Relative power uncertainty <sup>3</sup>	C/L-Band	$\pm$ 0.14 dB (0.12 dB typical)
	O-Band	$\pm$ 0.16 dB (0.14 dB typical)
Input power range	-38 to +19 dBm	
<b>Optical power</b>		
Insertion loss	< 4.0 dB (< 3.5 dB, typical)	
PDL (typical)	C/L band	< 0.2 dB
	O Band	< 0.5 dB
Maximum safe input power	20 dBm	

1. Ambient temperature change max.  $\pm$  0.5°C since normalization. Specification valid on day of calibration.
2. SOP/DOP measurements are possible outside the specification wavelength range if the user performs a manual calibration.
3. Input power > -20 dBm. The polarization analyzer readout reflects the SOP and power at the instrument output. Thus, effects caused by the internal polarization controller are included.
4. DOP > 95%.
5. User calibration requires a source with a 100% DOP. Valid at a fixed wavelength.
6. The instrument adaptively finds the polarization controller settings to let the SOP cycle through user-defined polarization states (closed loop operation). After having found these settings, the SOP can cycle through the polarization states in open loop operation.
7. This value is defined to be 5 times the standard deviation of the angular SOP error on the Poincaré sphere. Valid if controller is turned on. Power at instrument input > -10 dBm.

**Specifications <sup>1</sup> N7784B Polarization Controller (continued)****Ordering instructions****Optical connector options**

N7786B-021	Straight contact connectors
N7786B-022	Angled contact connectors

**Wavelength options**

N7786B-400	1270 to 1375 nm and 1460 to 1620 nm
N7786B-500	1460 to 1620 nm

**Connector interface**

The N7786B should usually be ordered with two 81000xl connector interfaces, depending on desired connector type (not included).

**Accessories**

5063-9240	Rack mount kit for 1 unit with filler panel
5063-9212 + 5061-9694	Rack mount parts for 2 units side-by-side

**Warranty****Select coverage**

Included	3-year warranty (return to Keysight), standard
R-51B-001-5Z	5-year warranty assurance plan (return to Keysight): Priority warranty service includes one-time coverage for an EOS/ESD failure.

**Calibration****Select Keysight calibration plan**

R-50C-011-3	3-year calibration assurance plan (return to Keysight): Priority calibration service covering all calibration costs for 3 years; 15% cheaper than buying stand-alone calibrations.
R-50C-011-5	5-year calibration assurance plan (return to Keysight): Priority calibration service covering all calibration costs for 5 years; 20% cheaper than buying stand-alone calibrations.

**General characteristics**

Dimensions (D x W x H)	380 mm x 213 mm x 88 mm (excluding front and back rubber cushions and handle)
Weight	Approx. 4 kg
Recommended recalibration period	24 months
Operating temperature	+5 °C to +40 °C
Operating humidity	0% to 80%, non-condensing
Altitude	The maximum operating altitude is 2000 m.
Pollution protection	Pollution degree 2.
Warm-up time	20 minutes
Interfaces	The instruments can be controlled via USB or GPIB interfaces
Power consumption	Line power: AC 100 to 240 V $\pm$ 10%, 50/60 Hz, 60 VA max.

**myKeysight**

**myKeysight**

[www.keysight.com/find/mykeysight](http://www.keysight.com/find/mykeysight)

A personalized view into the information most relevant to you.



**Three-Year Warranty**

[www.keysight.com/find/ThreeYearWarranty](http://www.keysight.com/find/ThreeYearWarranty)

Keysight's commitment to superior product quality and lower total cost of ownership. The only test and measurement company with three-year warranty standard on all instruments, worldwide.



**Keysight Assurance Plans**

[www.keysight.com/find/AssurancePlans](http://www.keysight.com/find/AssurancePlans)

Up to five years of protection and no budgetary surprises to ensure your instruments are operating to specification so you can rely on accurate measurements.



[www.keysight.com/quality](http://www.keysight.com/quality)

Keysight Electronic Measurement Group

DEKRA Certified ISO 9001:2008

Quality Management System

**Keysight Channel Partners**

[www.keysight.com/find/channelpartners](http://www.keysight.com/find/channelpartners)

Get the best of both worlds: Keysight's measurement expertise and product breadth, combined with channel partner convenience.

For more information on Keysight Technologies' products, applications or services, please contact your local Keysight office. The complete list is available at: [www.keysight.com/find/contactus](http://www.keysight.com/find/contactus)

**Americas**

Canada	(877) 894 4414
Brazil	55 11 33 51 7010
Mexico	001 800 254 2440
United States	(800) 829 4444

**Asia Pacific**

Australia	1 800 629 485
China	800 810 0189
Hong Kong	800 938 693
India	1 800 112 929
Japan	0120 (421) 345
Korea	080 769 0800
Malaysia	1 800 888 848
Singapore	1 800 375 8100
Taiwan	0800 047 866
Other AP Countries	(65) 6375 8100

**Europe & Middle East**

Belgium	32 (0) 2 404 93 40
Denmark	45 45 80 12 15
Finland	358 (0) 10 855 2100
France	0825 010 700*
	*0.125 €/minute
Germany	49 (0) 7031 464 6333
Ireland	1890 924 204
Israel	972-3-9288-504/544
Italy	39 02 92 60 8484
Netherlands	31 (0) 20 547 2111
Spain	34 (91) 631 3300
Sweden	0200-88 22 55
United Kingdom	44 (0) 118 927 6201

For other unlisted countries:

[www.keysight.com/find/contactus](http://www.keysight.com/find/contactus)

(BP-05-01-14)