

Operating and
Service Manual

Keysight Technologies
85059V
1.0 mm Precision
Verification Kit

Notices

© Keysight Technologies, Inc.
2003-2017

No part of this manual may be reproduced in any form or by any means (including electronic storage and retrieval or translation into a foreign language) without prior agreement and written consent from Keysight Technologies, Inc. as governed by United States and international copyright laws.

Trademark Acknowledgments

Manual Part Number

85059-90006

Edition

Edition 1, June 2017

Printed in USA/Malaysia

Published by:
Keysight Technologies
1400 Fountaingrove Parkway
Santa Rosa, CA 95403

Warranty

THE MATERIAL CONTAINED IN THIS DOCUMENT IS PROVIDED "AS IS," AND IS SUBJECT TO BEING CHANGED, WITHOUT NOTICE, IN FUTURE EDITIONS. FURTHER, TO THE MAXIMUM EXTENT PERMITTED BY APPLICABLE LAW, KEYSIGHT DISCLAIMS ALL WARRANTIES, EITHER EXPRESS OR IMPLIED WITH REGARD TO THIS MANUAL AND ANY INFORMATION CONTAINED HEREIN, INCLUDING BUT NOT LIMITED TO THE IMPLIED WARRANTIES OF MERCHANTABILITY AND FITNESS FOR A PARTICULAR PURPOSE. KEYSIGHT SHALL NOT BE LIABLE FOR ERRORS OR FOR INCIDENTAL OR CONSEQUENTIAL DAMAGES IN CONNECTION WITH THE FURNISHING, USE, OR PERFORMANCE OF THIS DOCUMENT OR ANY INFORMATION CONTAINED HEREIN. SHOULD KEYSIGHT AND THE USER HAVE A SEPARATE WRITTEN AGREEMENT WITH WARRANTY TERMS COVERING THE MATERIAL IN THIS

DOCUMENT THAT CONFLICT WITH THESE TERMS, THE WARRANTY TERMS IN THE SEPARATE AGREEMENT WILL CONTROL.

Technology Licenses

The hardware and/or software described in this document are furnished under a license and may be used or copied only in accordance with the terms of such license.

U.S. Government Rights

The Software is "commercial computer software," as defined by Federal Acquisition Regulation ("FAR") 2.101. Pursuant to FAR 12.212 and 27.405-3 and Department of Defense FAR Supplement ("DFARS") 227.7202, the U.S. government acquires commercial computer software under the same terms by which the software is customarily provided to the public. Accordingly, Keysight provides the Software to U.S. government customers under its standard commercial license, which is embodied in its End User License Agreement (EULA), a copy of which can be found at

<http://www.keysight.com/find/sweula>. The license set forth in the EULA represents the exclusive authority by which the U.S. government may use, modify, distribute, or disclose the Software. The EULA and the license set forth therein, does not require or permit, among other things, that Keysight: (1) Furnish technical information related to commercial computer software or commercial computer software documentation that is not customarily provided to the public; or (2) Relinquish to, or otherwise provide, the government rights in excess of these rights customarily provided to the public to use, modify, reproduce, release, perform, display, or disclose commercial computer software or commercial computer software documentation. No additional government requirements beyond those set forth in the EULA shall apply, except to the extent that those terms, rights, or licenses are explicitly required from all providers of commercial computer software pursuant to the FAR and the DFARS and are set forth specifically in

writing elsewhere in the EULA. Keysight shall be under no obligation to update, revise or otherwise modify the Software. With respect to any technical data as defined by FAR 2.101, pursuant to FAR 12.211 and 27.404.2 and DFARS 227.7102, the U.S. government acquires no greater than Limited Rights as defined in FAR 27.401 or DFAR 227.7103-5 (c), as applicable in any technical data.

Safety Notices

CAUTION

A **CAUTION** notice denotes a hazard. It calls attention to an operating procedure, practice, or the like that, if not correctly performed or adhered to, could result in damage to the product or loss of important data. Do not proceed beyond a CAUTION notice until the indicated conditions are fully understood and met.

WARNING

A **WARNING** notice denotes a hazard. It calls attention to an operating procedure, practice, or the like that, if not correctly performed or adhered to, could result in personal injury or death. Do not proceed beyond a WARNING notice until the indicated conditions are fully understood and met.

Contents

1. General Information

Chapter One at-a-Glance	1-1
About this Manual	1-1
Chapter One at-a-Glance	1-1
Verification Kit Overview	1-2
Kit Contents	1-2
Calibration Definitions	1-2
Installation of the Calibration Definitions	1-3
Equipment Required but Not Supplied	1-3
Recording the Device Serial Numbers	1-4
Clarifying the Terminology of a Connector Interface	1-5
Preventive Maintenance	1-5
Regulatory and Environmental Information	1-6

2. Specifications

Information in This Chapter	2-1
Chapter Two at-a-Glance	2-1
Environmental Requirements	2-2
Temperature—What To Watch Out For	2-2
Mechanical Characteristics	2-3
Pin Depth	2-3
Center Conductor Protrusion and Pin Depth	2-4
Electrical Characteristics	2-5
Supplemental Electrical Characteristics	2-5
Electrical Specifications	2-6

3. Use, Maintenance, and Care of the Devices

Information in this Chapter	3-1
Chapter Three at-a-Glance	3-1
Electrostatic Discharge	3-2
Visual Inspection	3-4
Look for Obvious Defects and Damage First	3-4
What Causes Connector Wear?	3-4
Connector Contacts	3-5
Concentricity	3-5
Inspect the Mating Plane Surfaces	3-6
Inspect Female Connectors	3-7
Supplies and Equipment Needed	3-7

Contents

Cleaning Connectors	3-8
Supplies and Equipment Needed	3-8
Basic Cleaning Procedure	3-8
Making a Connection	3-11
How to Make a Connection	3-12
Preliminary Connection	3-12
Connector Misalignment	3-13
How to Separate a Connection	3-13
Using a Torque Wrench	3-14
Handling and Storage	3-18
4. Performance Verification	
Information in This Chapter	4-1
Chapter Four at-a-Glance	4-1
Introduction	4-1
How Keysight Verifies the Devices in Your Kit	4-2
Recertification	4-2
How Often to Recertify	4-2
Where to Send a Kit for Recertification	4-3
5. Troubleshooting	
Information in This Chapter	5-1
Chapter Five at-a-Glance	5-1
Troubleshooting Process	5-1
Compatible Network Analyzers	5-3
Where to Look for More Information	5-3
Returning a Kit or Device to Keysight Technologies	5-4
Contacting Keysight	5-5
Printing Copies of Documentation from the Web	5-5
6. Replaceable Parts	
Information in This Chapter	6-1
Chapter Six at-a-Glance	6-1
Replacing the Verification Data	6-1
Replaceable Parts	6-2

1 General Information

Chapter One at-a-Glance

About this Manual

This manual describes the 85059V verification kit and provides replacement part numbers, specifications, and procedures for using, maintaining and troubleshooting this kit.

Chapter One at-a-Glance

Section Title	Summary of Content
“Verification Kit Overview” on page 1-2	Describes the 85059V calibration kit contents, how to identify shorts, and compatible network analyzers.
“Recording the Device Serial Numbers” on page 1-4	Describes how to record your calibration kit’s serial numbers in a table to avoid possible confusion with other calibration kits. Refer to Table 1-1 on page 1-4 .
“Clarifying the Terminology of a Connector Interface” on page 1-5	How to identify your different device types.
“Preventive Maintenance” on page 1-5	How to avoid damaging the devices in your verification kit.
“Regulatory and Environmental Information” on page 1-6	Description of regulatory symbols.

Verification Kit Overview

The Keysight 85059V 1.0 mm verification kit provides a set of standards with known characteristics, traceable to primary standards in the Keysight Technologies calibration lab. This set of standards is used to verify your measurement calibration and also to verify that your PNA system is operating within its specifications. The frequency range covered by the 85059V is from 10 MHz to 110 GHz.

Kit Contents

The 85059V verification kit includes the following items:

- Matched thru
- Mismatched thru
- Storage box
- User's and Service Guide (this manual)
- Form determining recalibration due date
- USB drive that contains factory-measured verification data for use with the PNA system verification process
- Data sheet for each device that contains factory-measured verification data
- Anti-virus scan report

Refer to **Chapter 6** for a complete list of replaceable part numbers.

NOTE

IMPORTANT! Backup copies of the data sheets, anti-virus scan reports, and the data contained on the USB drive should be made immediately upon receipt of the verification kit.

NOTE

A file containing the verification data for your kit is maintained for 18 months from the time of measurement. If you lose this data, refer to <https://service.keysight.com/infoline/public/default.aspx> or contact Keysight. Refer to **page 5-5**.

Calibration Definitions

The 85059V verification kit is intended to be used with the 85059V 1.0 mm calibration kits. Prior to performing a calibration with your PNA, the calibration kit must be selected and the calibration definitions for the devices in the kit installed in the PNA. Refer to your PNA Help system for instructions on selecting the calibration kit and performing a calibration.

Installation of the Calibration Definitions

The calibration definitions for the kit should be permanently installed in the internal memory or hard disk of the PNA. They may already be resident within the analyzer, or you can download them from Keysight's Calibration Kit Definitions Web page at

<http://na.support.keysight.com/pna/caldefs/stddefs.html>. In addition, the calibration definitions may be entered manually from the front panel. Refer to your PNA Help system for instructions.

Equipment Required but Not Supplied

Some items are required or recommended for successful operation of your kit, but are not supplied with the kit. Refer to **Table 6-2** for a list of these items and for ordering information.

Recording the Device Serial Numbers

In addition to the kit serial number, the devices in this kit are individually serialized. **Figure 1-1** shows an example of the laser-engraved serial number located on the nut of both beaded lines. The serial numbers of both attenuators are printed on the labels, located on the bodies of the devices. Record these serial numbers in **Table 1-1**. Recording the serial numbers will prevent confusing the devices in this kit with similar devices from other kits.

Figure 1-1 Serial Number Engraved on the Nut of a Beaded Line



Table 1-1 Serial Number Record for the 85059V

Device	Serial Number
Verification kit	_____
Mismatch adapter	_____
Match adapter	_____

Clarifying the Terminology of a Connector Interface

In this document and in the prompts of the PNA calibration wizard, the gender of cable connectors and adapters is referred to in terms of the center conductor. For example, a connector or device designated as 1.0 mm –f– has a 1.0 mm female center conductor.

A connector gage is referred to in terms of the connector that it measures. For instance, a male connector gage has a female connector on the gage so that it can measure male devices.

Preventive Maintenance

The best techniques for maintaining the integrity of the devices in this kit include:

- routine visual inspection
- cleaning
- proper pin depth
- proper connection techniques

All of these are described in **Chapter 3**. Failure to detect and remove dirt or metallic particles on a mating plane surface can degrade repeatability and accuracy and can damage any connector mated to it. Improper connections, resulting from pin depth values being out of specification (see **Table 2-2 on page 2-3**), or from bad connection techniques, can also damage these devices.

Regulatory and Environmental Information

This section contains information that is required by various government regulatory agencies.



The CE mark is a registered trademark of the European Community. (If accompanied by a year, it is when the design was proven.)

ccr.keysight@key
sight.com

The Keysight email address is required by EU directives applicable to our product.



This symbol indicates separate collection for electrical and electronic equipment, mandated under EU law as of August 13, 2005. All electrical and electronic equipment are required to be separated from normal waste for disposal (Reference WEEE Directive, 2002/96/EC).



China RoHS regulations include requirements related to packaging, and require compliance to China standard GB18455-2001.



This symbol indicates compliance with China RoHS regulations for paper/fiberboard packaging.

2 Specifications

Information in This Chapter

Chapter Two at-a-Glance

Section Title	Summary of Content
“Environmental Requirements” on page 2-2	Describes the operating and storage environmental conditions for your calibration kit.
“Mechanical Characteristics” on page 2-3	A discussion of the mechanical characteristics of the calibration devices including: temperature.
“Electrical Characteristics” on page 2-5	A discussion of the electrical characteristics of the calibration devices.
“Electrical Specifications” on page 2-6	A discussion of the electrical specifications of the calibration devices.

Environmental Requirements

Table 2-1 Environmental Requirements

Parameter	Required Values/Ranges
Temperature	
Operating ^a	+20 °C to +26 °C (+68 °F to +79 °F)
Storage	-40 °C to +75 °C (-40 °F to +167 °F)
Error-corrected range ^b	±1 °C (1.8 °F) of measurement calibration temperature
Altitude	
Operating	< 4,500 meters (*15,000 feet)
Storage	< 15,000 meters (*50,000 feet)
Relative humidity	Always non-condensing
Storage	0 to 90%

- a. The temperature range over which the calibration standards maintain conformance to their specifications.
- b. The allowable network analyzer ambient temperature drift during measurement calibration and during measurements when the network analyzer error correction is turned on. Also, the range over which the network analyzer maintains its specified performance while correction is turned on.

Temperature—What To Watch Out For

Due to the thermal properties of the devices, electrical characteristics will change with temperature. Therefore, the operating temperature is a critical factor in their performance, and must be stable before use.

NOTE

IMPORTANT! Avoid unnecessary handling of the devices during use because your fingers are a heat source.

Performance verification and measurements of devices-under-test (DUTs) do not need to be performed within the operating temperature range of the calibration devices. However, the DUTs must be within the error-corrected temperature range of the network analyzer ($\pm 1^\circ\text{C}$ of the measurement calibration temperature). For example, if the calibration is performed at $+20^\circ\text{C}$, the error-corrected temperature range is $+19^\circ$ to $+21^\circ\text{C}$. It is then appropriate to perform measurements and performance verifications even though $+19^\circ$ is outside the operating temperature range of the calibration devices.

Mechanical Characteristics

Mechanical characteristics such as center conductor protrusion and pin depth are not warranted performance specifications. They are, however, important supplemental characteristics related to electrical performance. Keysight Technologies verifies the mechanical characteristics of the devices in this kit with special gaging processes and electrical testing. This ensures that the device connectors do not exhibit any improper pin depth when the kit leaves the factory.

Refer to [Table 2-2 on page 2-3](#) for allowable recession.

Table 2-2 Mismatch/Match Adapter Typical Mechanical Characteristics

Characteristic	Typical Value
Inside Diameter of Outer Conductor	1.000 ± 0.005 mm
Outside Diameter of Center Conductor	0.434 ± 0.003 mm
Offset Length	Nominal ± 0.008 mm
Pin Depth	0.004 (recessed) to 0.024 mm (maximum recession)

Pin Depth

Pin depth is the distance the center conductor mating plane differs from being flush with the outer conductor mating plane. See [Figure 2-1](#). The pin depth of a connector can be in one of two conditions:

- Protrusion is the condition in which the center conductor extends beyond the outer conductor mating plane.
- Recession is the condition in which the center conductor is set back from the outer conductor mating plane.

Figure 2-1 Connector Pin Depth

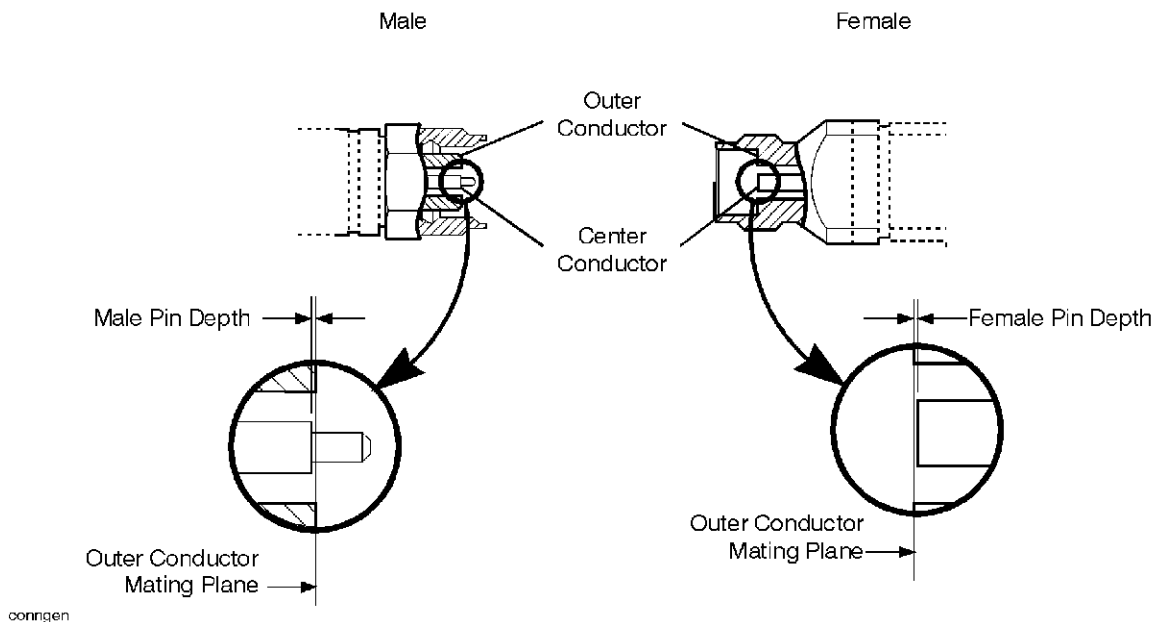

Center Conductor Protrusion and Pin Depth

Mechanical characteristics such as center conductor protrusion and pin depth are not performance specifications. They are, however, important supplemental characteristics related to electrical performance.

Keysight Technologies verifies the mechanical characteristics of the devices in this kit with special gaging processes and electrical testing. This ensures that the device connectors do not exhibit any center conductor protrusion and have proper pin depth when the kit leaves the factory.

Electrical Characteristics

Supplemental Electrical Characteristics

Table 2-3 Match Verification Standard Typical Electrical Characteristics

Characteristic	Typical Value @ 0 - 120 GHz
Return Loss	14 dB
Insertion Loss	< 0.70 dB
Connector Repeatability	-35 dB

Table 2-4 Mismatch Verification Standard Typical Electrical Characteristics

Characteristic	Typical Value @ 0 - 120 GHz
Return Loss	5 dB
Insertion Loss	< 3.0 dB
Connector Repeatability	-35 dB

Electrical Specifications

At the factory, each verification device is electrically characterized on a PNA measurement system. These factory measurements are traceable to the National Institute of Standards and Technology (NIST) through mechanical and electrical paths (for more information on traceability, contact Keysight Technologies. Refer to [page 5-5](#)).

The factory-measured data for each device is supplied in print and on USB drive with your kit.

3 Use, Maintenance, and Care of the Devices

Information in this Chapter

Chapter Three at-a-Glance

Section Title	Summary of Content
“Electrostatic Discharge” on page 3-2	How to protect your instruments and devices against electrostatic discharge.
“Visual Inspection” on page 3-4	A discussion of visually inspecting your devices and connections.
“Cleaning Connectors” on page 3-8	How to clean your connectors.
“How to Make a Connection” on page 3-12	Discussion of making connections. Includes a discussion of proper torquing procedures and properly connecting and separating connections.
“Using a Torque Wrench” on page 3-14	How to use a torque wrench for consistent measurements and avoiding damaging a device.
“Handling and Storage” on page 3-18	How to properly store your devices.

Electrostatic Discharge

Protection against electrostatic discharge (ESD) is essential while connecting, inspecting, or cleaning connectors attached to a static-sensitive circuit (such as those found in test sets).

Static electricity can build up on your body and can easily damage sensitive internal circuit elements when discharged. Static discharges too small to be felt can cause permanent damage. Devices such as calibration components and devices under test (DUT), can also carry an electrostatic charge. To prevent damage to the test set, components, and devices:

- **always** wear a grounded wrist strap having a 1 M Ω resistor in series with it when handling components and devices or when making connections to the test set.
- **always** use a grounded, conductive table mat while making connections.
- **always** wear a heel strap when working in an area with a conductive floor. If you are uncertain about the conductivity of your floor, wear a heel strap.
- **always** ground yourself before you clean, inspect, or make a connection to a static-sensitive device or test port. You can, for example, grasp the grounded outer shell of the test port or cable connector briefly.
- **always** ground the center conductor of a test cable before making a connection to the analyzer test port or other static-sensitive device. This can be done as follows:
 1. Connect a short (from your calibration kit) to one end of the cable to short the center conductor to the outer conductor.
 2. While wearing a grounded wrist strap, grasp the outer shell of the cable connector.
 3. Connect the other end of the cable to the test port.
 4. Remove the short from the cable.

Figure 3-1 shows a typical ESD protection setup using a grounded mat and a wrist strap. Refer to **Table 6-2** for information on ordering supplies for ESD protection.

Figure 3-1 ESD Protection Setup

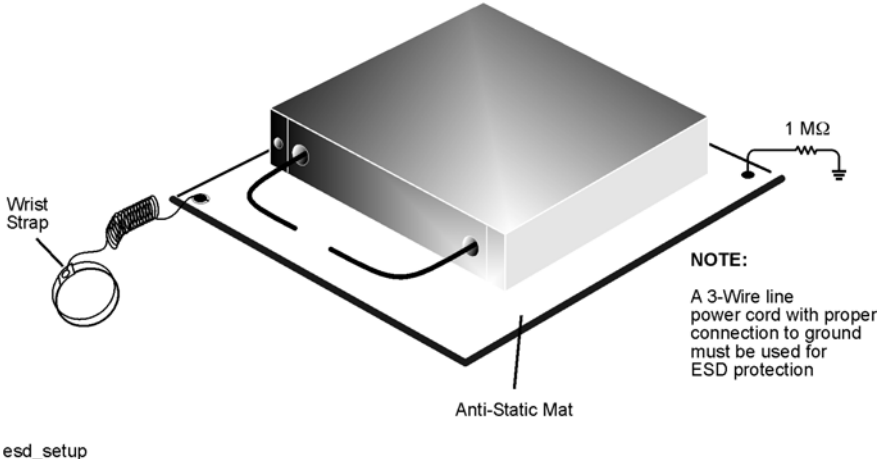

Visual Inspection

Visual inspection and, if necessary, cleaning should be done every time a connection is made. Metal particles from the connector threads may fall into the connector when it is disconnected.

CAUTION

Devices with damaged connectors should be immediately discarded or clearly marked and set aside for repair. A damaged device will in turn damage any good connector to which it is attached. Determine the cause of the damage before connecting a new, undamaged connector in the same configuration.

Magnification is helpful when inspecting connectors, but it is not required and may actually be misleading. Defects and damage that cannot be seen without magnification generally have no effect on electrical or mechanical performance. Magnification is of great use in analyzing the nature and cause of damage and in cleaning connectors, but it is not required for inspection.

Look for Obvious Defects and Damage First

Examine the connectors first for obvious defects or damage: badly worn plating on the connector interface, deformed threads or bent, broken, or misaligned center conductors. Connector nuts should move smoothly and be free of burrs, loose metal particles, and rough spots.

What Causes Connector Wear?

Connector wear is caused by connecting and disconnecting the devices. The more use a connector gets, the faster it wears and degrades. The wear is greatly accelerated when connectors are not kept clean, or are not connected properly.

Connector wear eventually degrades performance of the device. Verification devices should have a long life if their use is on the order of a few times per week. Replace devices with worn connectors.

The test port connectors on the PNA test set may have many connections each day, and are, therefore, more subject to wear. It is recommended that an adapter be used as a test port saver to minimize the wear on the test set's test port connectors.

Obvious Defects or Damage

Examine the connectors first for obvious defects or damage:

- Plating
 - Bare metal showing
 - Burrs or blisters
- Deformed threads

- Center Conductors
 - Bent
 - Broken
 - Misaligned
 - Concentricity

Connector nuts should move smoothly and be free of:

- Burrs
- Loose metal particles
- Rough spots

Any connector that has obvious defects should be discarded or sent for repair - refer to **“Contacting Keysight” on page 6-2**.

Connector Contacts

See **Figure 3-2 on page 3-5** for visual guidelines when evaluating the contact integrity of a connector.

NOTE

Notice the location of the cross hairs in relationship to the center of the figures.

Figure 3-2 Contact Integrity

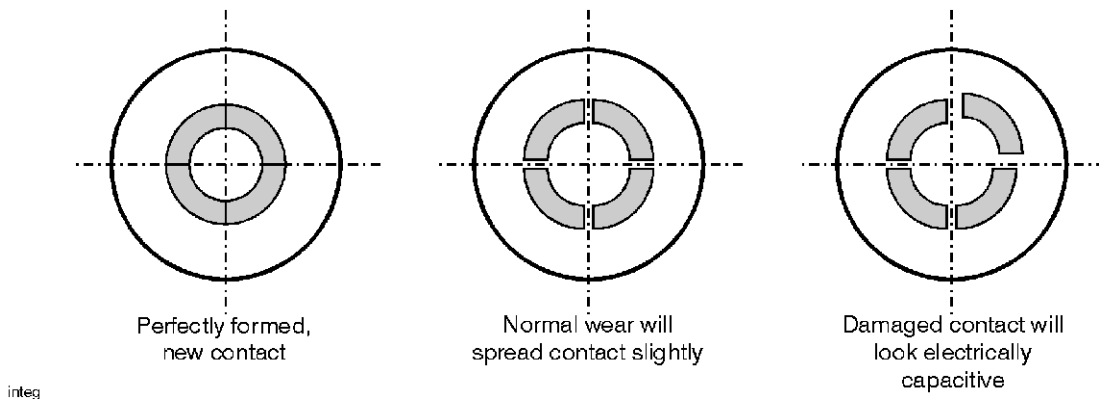

Concentricity

Figure 3-3 and **Figure 3-4** show the concentricity of both the male and female 1.0 mm connectors. Inspect the connectors with a minimum magnification of 10X.

Figure 3-3 Concentricity of a Female Connector

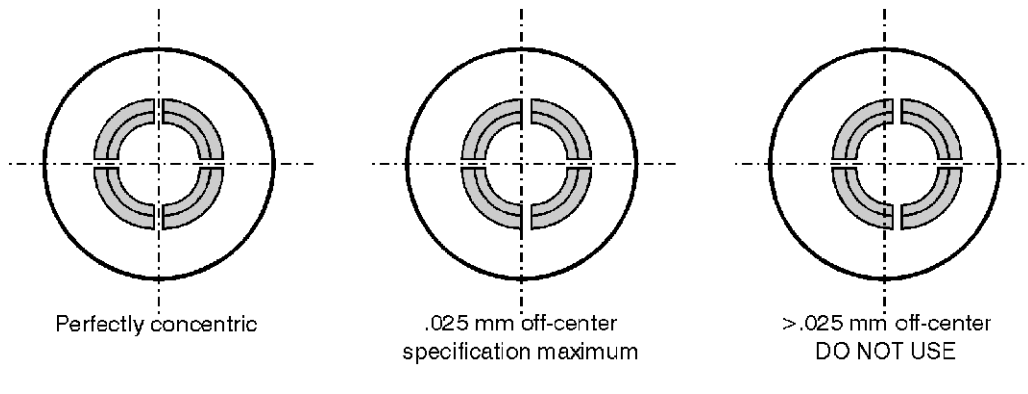
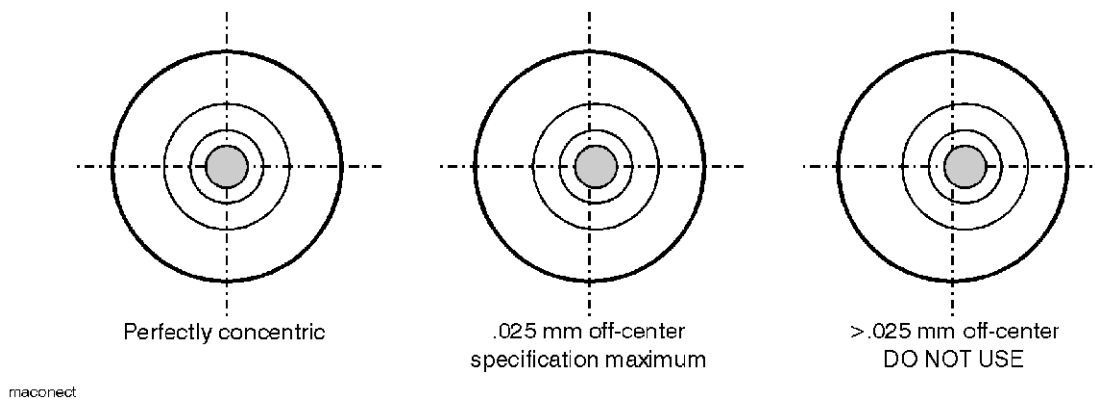

Figure 3-4 Concentricity of a Male Connector



Inspect the Mating Plane Surfaces

Flat contact between the connectors at all points on their mating plane surfaces is required for a good connection. See [Figure 2-1 on page 2-4](#). Look especially for deep scratches or dents, and for dirt and metal particles on the connector mating plane surfaces. Also look for signs of damage due to excessive or uneven wear or misalignment.

Light burnishing of the mating plane surfaces is normal, and is evident as light scratches or shallow circular marks distributed more or less uniformly over the mating plane surface. Other small defects and cosmetic imperfections are also normal. None of these affect electrical or mechanical performance. If a connector shows deep scratches or dents, particles clinging to the mating plane surfaces, or uneven wear, clean and inspect it again.

Clean and inspect the connector again if it shows:

- Deep scratches or dents
- Particles clinging to the mating plane surfaces
- Uneven wear

Damaged connectors should be discarded or sent for repair. Try to determine the cause of damage before connecting a new, undamaged connector in the same configuration. Magnification is of great use in analyzing the nature and cause of damaged connectors.

Inspect Female Connectors

The 1.0 mm slotted female connector is designed and fabricated to meet and exceed the performance requirements of an instrument-grade connector. In order to maintain this performance level, the female contacts of each device should be inspected prior to use. Refer to **Figure 3-2 on page 3-5**. Make sure that the contacts are formed symmetrically. The outside edge of the contacts must be very sharp. Also, the center conductor must be free of nicks, scratches, and dings.

NOTE

Inspection of connectors is particularly important when mating nonprecision to precision devices.

Supplies and Equipment Needed

The supplies and equipment needed to perform the cleaning procedure, and their Keysight Technologies part numbers are listed in **Table 7-1, “ Replaceable Parts”, on page 2** and page 7-3

Cleaning Connectors

Supplies and Equipment Needed

The supplies and equipment that are needed to perform the cleaning procedures, and their Keysight Technologies part numbers are listed in Table 7-1 on page 7-2 and page 7-3.

Basic Cleaning Procedure

1. Use Compressed Air or Nitrogen

Clean connectors are essential for ensuring the integrity of RF and microwave coaxial connections.

WARNING

Always use protective eyewear when using compressed air or nitrogen.

Use compressed air (or nitrogen) to loosen particles on the connector mating plane surfaces.

You can use any source of clean, dry, low-pressure compressed air or nitrogen that has an effective oil-vapor filter and liquid condensation trap placed just before the outlet hose.

Ground the hose nozzle to prevent electrostatic discharge, and set the air pressure to less than 414 kPa (60 psi) to control the velocity of the air stream. High-velocity streams of compressed air can cause electrostatic effects when directed into a connector. These electrostatic effects can damage the device. Refer to [“Electrostatic Discharge” on page 3-2](#) for additional information.

2. Clean the Connector Threads

WARNING

Keep isopropyl alcohol away from heat, sparks, and flame. Store in a tightly closed container. It is extremely flammable. In case of fire, use alcohol foam, dry chemical, or carbon dioxide; water may be ineffective.

Use isopropyl alcohol with adequate ventilation and avoid contact with eyes, skin, and clothing. It causes skin irritation, may cause eye damage, and is harmful if swallowed or inhaled. It may be harmful if absorbed through the skin. Wash thoroughly after handling.

In case of spill, soak up with sand or earth. Flush spill area with water.

Dispose of isopropyl alcohol in accordance with all applicable federal, state, and local environmental regulations.

Use a lint-free swab or cleaning cloth moistened with isopropyl alcohol to remove any dirt or stubborn contaminants on a connector that cannot be removed with compressed air or nitrogen. Refer to [Table 6-2](#) for part numbers for isopropyl alcohol and cleaning swabs.

- a. Apply a small amount of isopropyl alcohol to a lint-free cleaning swab.
- b. Clean the connector threads.
- c. Let the alcohol evaporate, then blow the threads dry with a gentle stream of clean, low-pressure compressed air or nitrogen. Always completely dry a connector before you reassemble or use it.

3. Clean the Mating Plane Surfaces

- a. Apply a small amount of isopropyl alcohol to a lint-free cleaning swab.

CAUTION

When using isopropyl alcohol to clean connectors do not allow the liquid to flow down inside the connector. This may cause measurement errors due to residue inside the connector. If possible keep the connector facing down.

-
- b. **Gently** clean the center and outer conductor mating plane surfaces. Refer to [Figure 2-1 on page 2-4](#). When cleaning a female connector, avoid snagging the swab on the center conductor contact fingers by using short strokes.
 - c. Let the alcohol evaporate, then blow the connector dry with a gentle stream of clean, low-pressure compressed air or nitrogen. Always completely dry a connector before you reassemble or use it.

4. Reinspect

Inspect the connector again to make sure that no particles or residue are present.

Figure 3-5 Cleaning Illustration

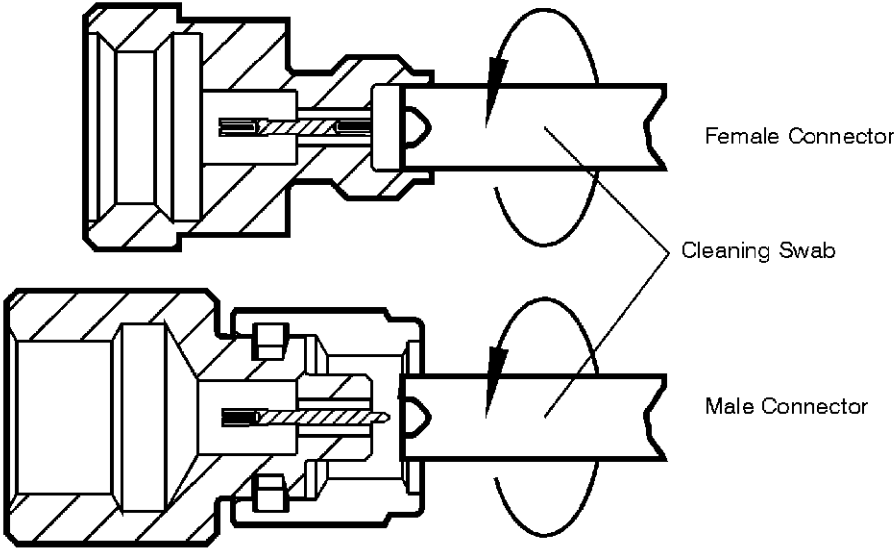

cleaning

Making a Connection

Good connections require a skilled operator. Instrument sensitivity and coaxial connector mechanical tolerances are such that slight errors in operator technique can have a significant effect on measurements and measurement uncertainties.

CAUTION

The most common cause of measurement error is poor connections.

How to Make a Connection

Preliminary Connection

1. Ground yourself and all devices. Wear a grounded wrist strap and work on a grounded, conductive table mat. Refer to “**Electrostatic Discharge**” on **page 3-2** for ESD precautions.
2. Visually inspect the connectors. Refer to “**Visual Inspection**” on **page 3-4**.
3. If necessary, clean the connectors. Refer to “**Cleaning Connectors**” on **page 3-8**.
4. Carefully align the connectors. The male connector center pin must slip concentrically into the contact finger of the female connector.
5. Push the connectors straight together and tighten the connector nut finger tight. As the center conductors mate, there is usually a slight resistance.

CAUTION

Do **not** twist one connector into the other (like inserting a light bulb). This happens when you turn the device body, rather than the connector nut. Major damage to the center conductor and the outer conductor can occur if the device body is twisted.

6. Initial tightening can be done by hand, or with a 6 mm open-end wrench. Tighten until “snug” or where the connectors are first making contact. The preliminary connection is tight enough when the mating plane surfaces make uniform, light contact. **Do not overtighten** this connection.

At this point, all you want is for the outer conductors to make gentle contact on both mating surfaces. Use very light finger pressure (no more than 2 inch-pounds of torque).

7. Relieve any side pressure on the connection from long or heavy devices, or cables. This assures consistent torque (refer to “Using the Torque Wrench” on page 3-14).

Figure 3-6 Alignment

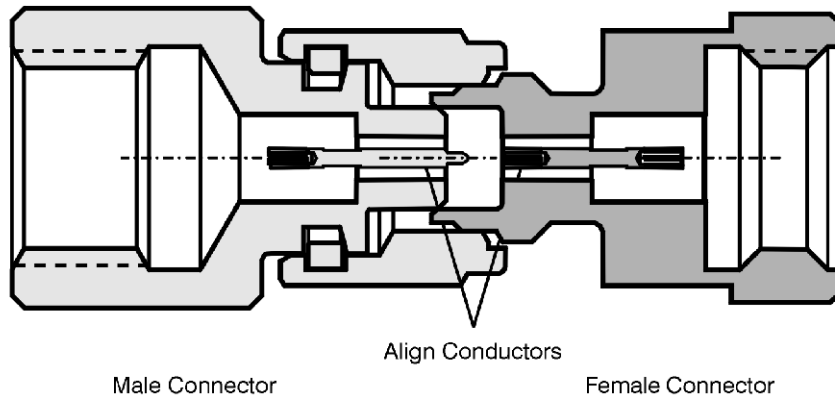

alignmnt

Connector Misalignment

Forced misalignment could damage the female center conductor.

Figure 3-7 Misalignment

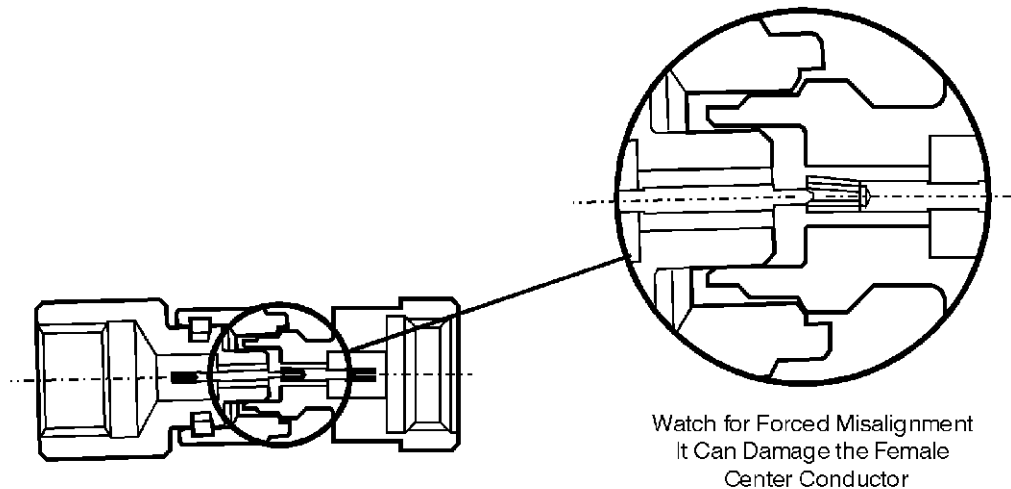

misalign

How to Separate a Connection

To avoid lateral (bending) force on the connector mating plane surfaces, always support the devices and connections.

CAUTION

Turn the connector nut, **not** the device body. Major damage to the center conductor can occur if the device body is twisted.

1. Use an open-end wrench to prevent the device body from turning.

2. Use another open-end wrench to loosen the connector nut.
3. Complete the separation by hand, turning only the connector nut.
4. Pull the connectors straight apart without twisting, rocking, or bending either of the connectors.

Using a Torque Wrench

Use a torque wrench to make a final connection. [Table 3-1](#) provides information about the torque wrench recommended for use with the verification kit. A torque wrench is not included in the verification kit. Refer to [Table 6-2](#) for part number and ordering information.

Table 3-1 Torque Wrench Information

Connector Type	Torque Setting	Torque Tolerance
1.0 mm	45 N-cm (4 in-lb)	±5.4 N-cm (±0.5 in-lb)

Using a torque wrench guarantees that the connection is not too tight, preventing possible connector damage. It also guarantees that all connections are equally tight each time.

NOTE

Do not pre-tighten the connector nut so much that there is no rotation of the nut with the torque wrench. Static friction must *not* be present during torquing.

Prevent the rotation of anything other than the connector nut that you are tightening. It may be possible to do this by hand if one of the connectors is fixed (as on a test port). However, it is recommended that you use an open-end wrench to keep the body of the device from turning.

1. Use the torque wrench supplied with your kit to make the final connections.
2. Rotate **only** the connector nut when you tighten the connector.

In all situations, use an open-end wrench to keep the body of the device from turning. Position both wrenches within 90 degrees of each other before applying force (see [Figure 3-8 on page 3-15](#)). Wrenches opposing each other (180 degrees apart) will cause a lifting action (see [Figure 3-9 on page 3-15](#)). This lifting action can misalign, and stress the connections of the devices involved. This is especially true when several devices are connected together.

Figure 3-8 Correct Wrench Position

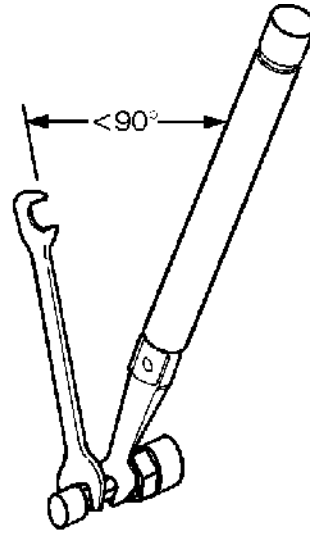

wj67d

Narrow separation of the wrenches produces a small residual lateral force on the structure of connected devices.

Figure 3-9 Incorrect Torque Wrench

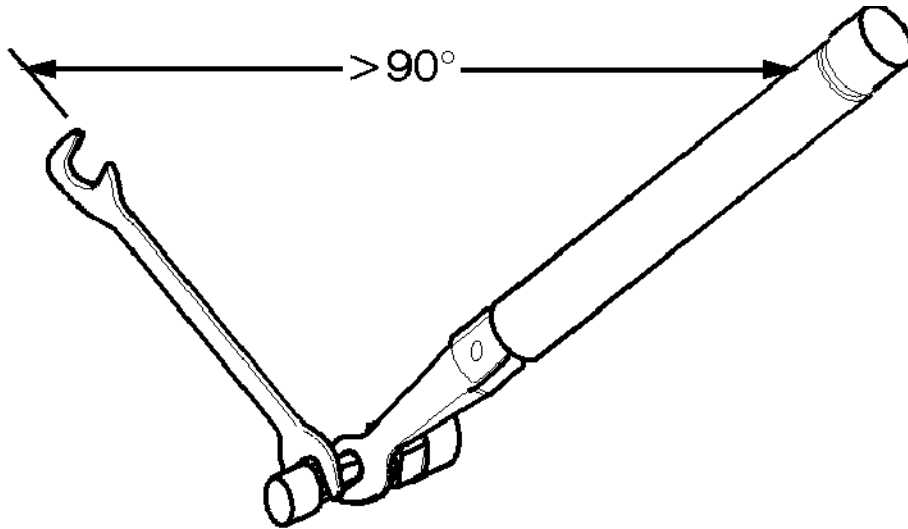

3. Hold the torque wrench lightly, at the end of the handle only (beyond the groove). See [Figure 3-10 on page 3-16](#).

Wide separation of the wrenches produces a larger residual lateral force on the structure of connected devices. This can degrade connector repeatability.

Figure 3-10 Where to Hold the Torque Wrench

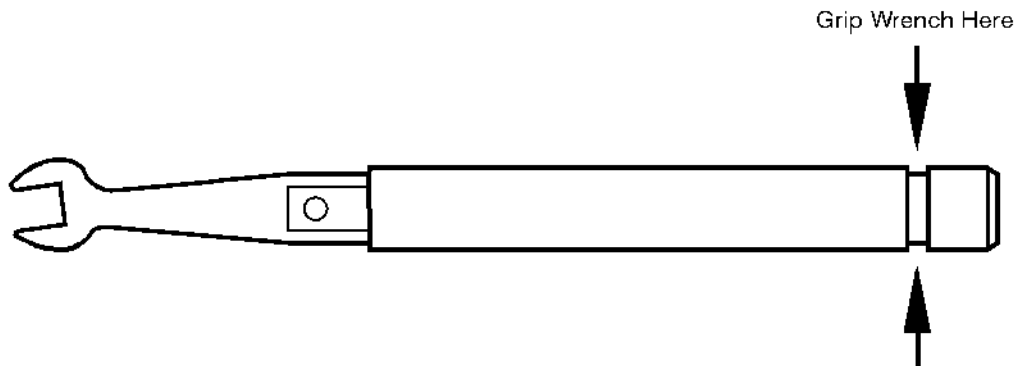

4. Apply downward force perpendicular to the wrench handle. This applies torque to the connection through the wrench.

Do **not** hold the wrench so tightly that you push the handle straight down along its length rather than pivoting it, otherwise, you apply an unknown amount of torque.

Figure 3-11 Using the Torque Wrench

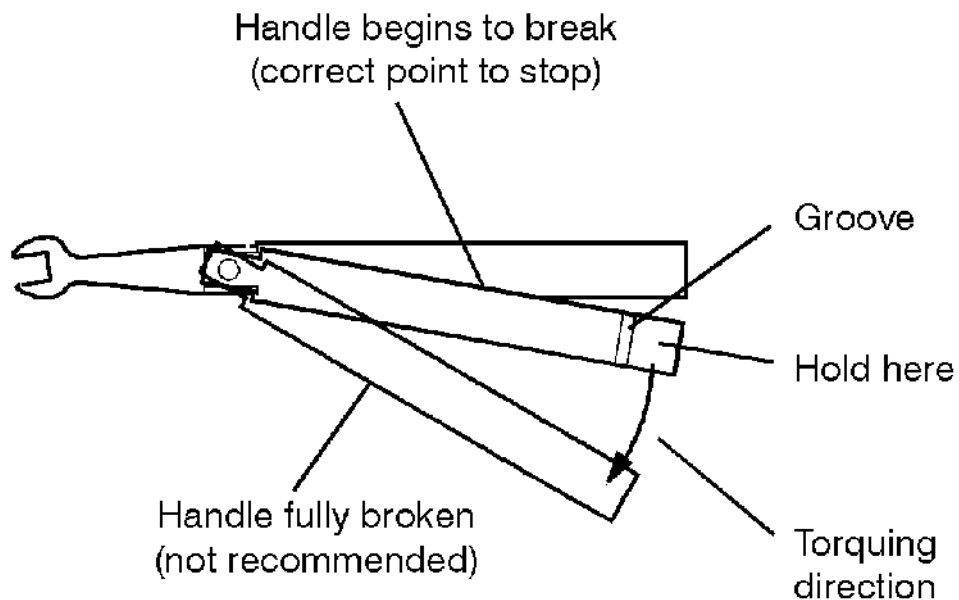

5. Tighten the connection just to the torque wrench break point. The wrench handle gives way at its internal pivot point. See [Figure 3-11](#). Do not tighten the connection further.

CAUTION

You don't have to fully break the handle of the torque wrench to reach the specified torque; doing so can cause the handle to kick back and loosen the connection. Any give at all in the handle is sufficient torque.

Do not pivot the wrench handle on your thumb or other fingers, otherwise you apply an unknown amount of torque to the connection when the wrench reaches its break point.

Do not twist the head of the wrench relative to the outer conductor mating plane. If you do, you apply more than the recommended torque.

Handling and Storage

- **Do** install the protective end caps and store the devices in the foam-lined storage case when not in use.
- **Do** keep connectors and beaded lines clean.
- **Do not** store connectors and beaded lines loose in a box, or in a desk or bench drawer. This is the most common cause of connector damage during storage.
- **Do not** touch mating plane surfaces. Natural skin oils and microscopic particles of dirt are easily transferred to a connector interface and are very difficult to remove.
- **Do not** set connectors contact-end down on a hard surface. The plating and the mating plane surfaces can be damaged if the interface comes in contact with any hard surface.

4 Performance Verification

Information in This Chapter

Chapter Four at-a-Glance

Section Title	Summary of Content
“Introduction” on page 4-1	Overview of how to recertify the 85059V kit.
“How Keysight Verifies the Devices in Your Kit” on page 4-2	Discusses what is provided with the recertification and how often to recertify the calibration kit.
“Recertification” on page 4-2	A discussion on the steps Keysight uses to verify a calibration kit.
“Where to Send a Kit for Recertification” on page 4-3	Where to send your kit for certification.

Introduction

The performance of your verification kit can only be verified by returning the kit to Keysight Technologies for recertification. The equipment required to verify the specifications of the devices in the kit has been specially manufactured and is not commercially available.

How Keysight Verifies the Devices in Your Kit

Keysight verifies the specifications of these devices as follows:

1. The residual microwave error terms of the test system are verified with precision airlines and shorts that are directly traced to the National Institute of Standards and Technology (NIST). The airline and short characteristics are developed from mechanical measurements. The mechanical measurements and material properties are carefully modeled to give very accurate electrical representation. The mechanical measurements are then traced to NIST through various plug and ring gages and other mechanical measurements.
2. Each device is electrically tested on this system. The measurement uncertainty for each device is recorded in the calibration report that accompanies every kit.

These two steps establish a traceable link to NIST for Keysight to the extent allowed by the institute's calibration facility. The specifications data provided for the devices in the kit is traceable to NIST through Keysight Technologies.

Recertification

The following will be provided with a recertified kit:

- a new calibration sticker affixed to the case
- a certificate of calibration
- a calibration report for each device in the kit listing measured values, specifications, and uncertainties

NOTE

A list of NIST traceable numbers may be purchased upon request to be included in the calibration report.

Keysight Technologies offers a **Standard** calibration for the recertification of the kit. For more information, contact Keysight Technologies. Refer to [page 5-5](#).

How Often to Recertify

The suggested initial interval for recertification is 12 months or sooner. The actual need for recertification depends on the use of the kit. After reviewing the results of the initial recertification, you may establish a different recertification interval that reflects the usage and wear of the kit.

NOTE

The recertification interval should begin on the date the kit is **first used** after the recertification date.

Where to Send a Kit for Recertification

Contact Keysight Technologies for information on where to send your kit for recertification. Contact information is listed on [page 5-5](#). Refer to **“Returning a Kit or Device to Keysight Technologies”** on [page 5-4](#) for details on sending your kit.

Performance Verification
Where to Send a Kit for Recertification

5 Troubleshooting

Information in This Chapter

Chapter Five at-a-Glance

Section Title	Summary of Content
“Troubleshooting Process” on page 5-1	How to troubleshoot a calibration problem. Includes a flow troubleshooting diagram.
“Compatible Network Analyzers” on page 5-3	Discusses which network analyzers are compatible with this verification kit.
“Where to Look for More Information” on page 5-3	Where to find more information on network analyzer system operation.
“Returning a Kit or Device to Keysight Technologies” on page 5-4	Where to return a kit to Keysight and the required information.
“Contacting Keysight” on page 5-5	How to contact Keysight.

Troubleshooting Process

If your PNA does not pass performance verification, follow the steps in [Figure 5-1](#) to determine the cause of the failure and the correct action to take to correct the failure.

Figure 5-1 Troubleshooting Flowchart

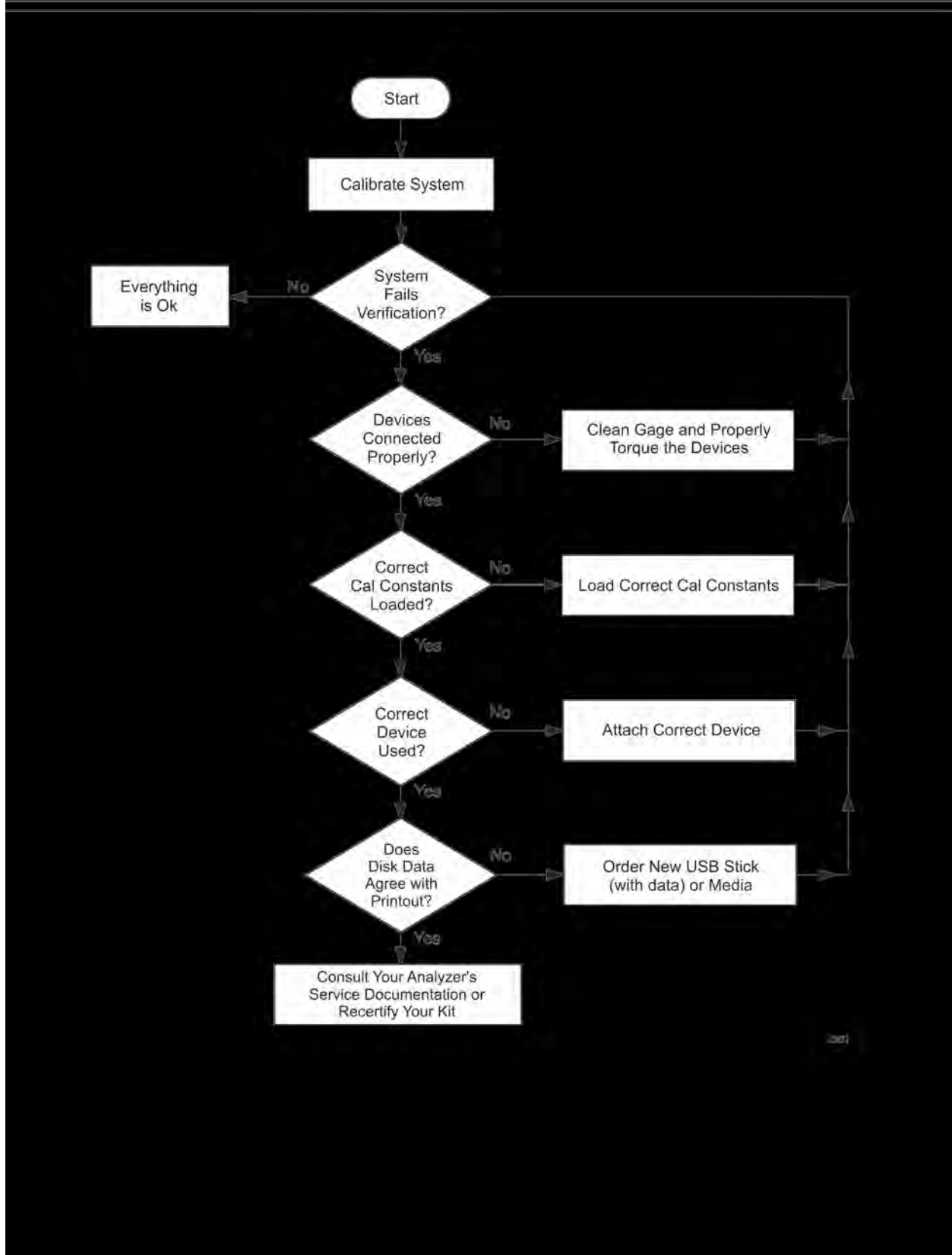

Compatible Network Analyzers

The devices in this kit and their data are compatible with the PNA series network analyzers. The USB drive provided contains the unique factory-measured S-parameter data for each device in this kit. It also contains the factory measurement uncertainty used in the PNA system verification procedure to calculate the test limits.

Where to Look for More Information

This manual contains limited information about PNA series network analyzer system operation. For detailed information on using a PNA, refer to the PNA Help system. To do so, press the Help key on the front panel of the PNA.

If you need additional information, see **“Contacting Keysight” on page 5-5**.

- To view the ENA or PNA Help, press the Help key on the front panel of the network analyzer.
- To view Help or a user guide online, use the following steps:
 1. Go to www.keysight.com/find/assist.
 2. Enter your analyzer model number (Ex: N5242B) in the search box and press return.
 3. Under the heading of your network analyzer, click on the **Support** tab and then the **Document Library** icon.
 4. Click on the document PDF you want to view.

If you need additional information, see **“Contacting Keysight” on page 5-5**.

Returning a Kit or Device to Keysight Technologies

If your kit or device requires service, contact Keysight Technologies for information on where to send it and provide the following:

- your company name and address
- a technical contact person within your company, and the person's complete telephone number including country code and area code
- the model number and serial number of the kit (if returning a complete kit)
- the model number(s) of your network analyzer(s)
- the part number and serial number of each device being returned
- the type of service required
- a **detailed** description of the problem (if applicable) and how the device was being used when the problem occurred
- see also, **“Contacting Keysight” on page 5-5**

Contacting Keysight

Assistance with test and measurements needs and information on finding a local Keysight office are available on the Web at:

www.keysight.com/find/assist

If you do not have access to the Internet, please contact your Keysight field engineer.

NOTE

In any correspondence or telephone conversation, refer to the Keysight product by its model number and full serial number. With this information, the Keysight representative can determine whether your product is still within its warranty period.

Printing Copies of Documentation from the Web

To print copies of documentation from the Web, download the PDF file from the Keysight web site:

- Go to www.keysight.com.
- Enter the document's part number (located on the title page) in the Search box.
- Click Search
- Open the PDF and print the document.

Troubleshooting
Contacting Keysight

6 Replaceable Parts

Information in This Chapter

Chapter Six at-a-Glance

Section Title	Summary of Content
“Replacing the Verification Data” on page 6-1	A discussion of what to do verification data
“Replaceable Parts” on page 6-2	Table of Replaceable Parts (See Table 6-1 on page 6-2)

Replacing the Verification Data

The verification data contains unique performance data that applies to the individual verification devices. No two devices have the same performance data. It is not a trivial matter to replace lost or damaged data, so it is important to make one or more backup copies.

If your verification data is lost or damaged, and you have no backup copies, take one of the following actions:

- If recertification is not required in the near future.

Contact Keysight for replacement verification data – refer to [“Contacting Keysight” on page 5-5](#). Please specify the model and serial number of your kit.

- If recertification will be required in the near future.

Keysight recommends that you have the verification kit recertified early. New verification data will be generated during the recertification process. Refer to [“Recertification” on page 4-2](#).

NOTE

IMPORTANT! Keysight’s data retention policy is to hold verification data for 18 months. If it has been >18 months since your last recertification, your 85059V kit must be recertified. If you lose this data, refer to <https://service.keysight.com/infoline/public/default.aspx> or contact Keysight. Refer to [page 5-5](#).

Replaceable Parts

Table 6-1 lists the replacement part numbers for items included in the 85059V verification kit and **Figure 6-1** illustrates the attenuators and beaded lines.

Table 6-2 lists the replacement part numbers for items not included in the verification kit that are either required or recommended for successful operation of the kit.

To order a listed part, note the description, the part number, and the quantity desired. Telephone or send your order to Keysight Technologies. Refer to [page 5-5](#).

Verification standards only available through the Keysight recertification process. If a device becomes damaged, return your verification kit to Keysight for replacement of the verification standard and recertification.

Table 6-1 Replaceable Parts for the 85059V 1.0 mm Verification Kit

Description	Qty Per Kit	Keysight Part Number
Verification Standards		
Mismatch adapter data (for internal Keysight reference only)	1	85059-60047 ^a
Match adapter data (for internal Keysight reference only)	1	85059-60048 ^a
Miscellaneous Items		
Storage unit:		
Storage Box with customized foam inserts	1	1540-2334
User's and service guide	1	85059-90006 ^b

a. These part numbers are for internal Keysight reference only.

b. ["Printing Copies of Documentation from the Web" on page 5-5](#)

Table 6-2 Items Not Included in the Verification Kit

Description	Qty	Keysight Part Number
Wrenches		
6 mm open-end wrench	1	8710-2156
6 mm, 45 N-cm (4 in-lb) torque wrench	1	8710-2812
14 mm, 45 N-cm (4 in-lb) torque wrench	1	8710-2813
ESD Protection Devices		
Grounding wrist strap	1	9300-1367
5 ft grounding cord for wrist strap	1	9300-0980

Table 6-2 **Items Not Included in the Verification Kit**

2 x 4 ft conductive table mat and 15 ft ground wire	1	9300-0797
ESD heel strap (for conductive floors)	1	9300-1308
Connector Cleaning Supplies		
Isopropyl alcohol	--	--
Cleaning swabs	100	9301-1243

Replaceable Parts
Replaceable Parts

Index

A

alcohol, isopropyl
 as cleaning solvent 3-9
 altitude, specifications 2-2
 attenuator, part numbers 6-2

B

box, part number 6-2

C

calibration
 bad 5-1
 certificate of 4-2
 constants, See calibration definitions
 definitions
 entering 1-2
 permanently stored 1-2
 kits, intended to be used 1-2
 report 4-2
 standard 4-2
 temperature 2-2

case

storage, part number 6-2

center conductor

protrusion and pin depth 2-4

certificate of calibration 4-2

characteristics

mechanical 2-3
 supplemental 2-3

cleaning connectors 3-8

compatibility

with analyzers 5-3

compressed air or nitrogen 3-8

conductive table mat

part number 6-2

conductor, mating plane 2-3

connections 3-2, 3-11, 3-12, 3-13

disconnecting 3-13

ESD protection 3-12

final 3-14

preliminary 3-12

undoing 3-13

using torque wrench 3-14

connector

cleaning 3-8

damage 3-4

defects 3-4

female 3-7

mating plane surfaces 2-3, 3-9

cleaning 3-9

pin depth 2-3

terminology 1-5

threads

cleaning 3-8

inspecting 3-4

visual inspection 3-4

wear

affect on electrical performance 3-4

connector contacts

concentricity 3-6

integrity 3-5

constants, calibration, See calibration definitions

contacting Keysight Technologies 5-4

cord

grounding, part number 6-2

D

damage

device 3-4

electrostatic discharge 3-2

inspecting for 3-4

to connectors 3-4

damaged connectors 3-4

data

recertification 4-2

replacing 6-1

defective connectors 3-4

defects, connector 3-4

definitions

calibration 1-2

device

compatibility

with analyzers 5-3

conductor, mating plane 2-3

connecting 3-11

damage 3-4

disconnecting 3-13

handling 3-18

maintenance 1-5

performance, verifying 4-1

pin depth 2-3

specifications 2-6

traceability 4-2

storage 3-18

- temperature 2-2
- visual inspection 3-4
- disconnections 3-13
- documentation, part number 6-2

E

- electrical specifications 2-6
- electrostatic discharge, *See* ESD
- environmental
 - requirements 2-2
 - specifications 2-2
- equipment required 1-3
- ESD 3-2
 - precautions 3-2, 3-8
 - protection setup 3-2, 3-3
 - supplies, part numbers 6-2

F

- female connectors
 - inspection of 3-7
- flowchart, troubleshooting 5-2
- frequency range 1-2

G

- gender, connector 1-5
- grounding cord, part number 6-2

H

- handling 3-18
- heel strap
 - part number 6-2
- humidity, specifications 2-2

I

- information, troubleshooting 5-3
- inspection
 - damage 3-4
 - defects 3-4
 - female connectors 3-7
 - mating plane surfaces 3-6
 - visual 3-4
- isopropyl alcohol
 - as cleaning solvent 3-9
 - part number 6-3

K

- Keysight Technologies
 - contacting 5-4, 5-5
- kit

- calibration
 - intended to be used 1-2
- contents 1-2
- frequency range 1-2
- overview 1-2
- performance
 - how Keysight verifies 4-2

M

- maintenance 3-2
 - of devices 1-5
 - preventive 1-5
- making connections 3-12
 - ESD protection 3-12
 - precautions 3-12
- mat
 - conductive, part number 6-2
- mating plane
 - conductor 2-3
 - surfaces
 - cleaning 3-9
 - connector 3-9
 - inspection of 3-6
- mechanical characteristics 2-3
- mechanical integrity 2-3

N

- National Institute of Standards and Technology (NIST) 2-6, 4-2
- nitrogen, for cleaning 3-8
- numbers
 - replaceable parts 6-2
 - serial, recording 1-4

O

- open-end wrench 3-13
 - part number 6-2
- ordering parts 6-2

P

- parts
 - included in kit 6-2
 - not included in kit 6-2
- performance verification, failure 5-1
- permanently stored calibration definitions 1-3
- pin depth 2-3
 - definition of 2-3
 - protrusion 2-3
 - recession 2-3

preventive maintenance 1-5
 protrusion, pin depth 2-3

R

recertification
 how to order 4-3
 interval 4-2
 location 4-3
 services included 4-2
 recession, pin depth 2-3
 replaceable parts 6-2
 report, calibration 4-2
 requirements, environmental 2-2
 return
 kit or device to Keysight 5-4

S

serial numbers
 devices 1-4
 recording 1-4
 service tag 5-4
 servicing 5-4
 specifications 2-1
 device 2-6
 electrical 2-6
 environmental 2-2
 mechanical 2-3
 temperature 2-2
 torque wrench 3-14
 traceability 4-2
 standard calibration 4-2
 standards
 National Institute of Standards and Technology
 (NIST) 4-2
 static discharge, *See* ESD
 storage 3-18
 storage case, part number 6-2
 strap
 heel and wrist, part number 6-2
 supplemental characteristics 2-3

T

tag, service 5-4
 temperature
 affect on electrical performance 2-2
 environmental requirements 2-2
 specifications 2-2
 what to watch out for 2-2
 terminology, connector 1-5

test data 4-2
 threads, connector
 cleaning 3-8
 inspecting 3-4
 torque wrench
 part number 6-2
 specifications 3-14
 traceability
 of device specifications 4-2
 troubleshooting 5-1
 flowchart 5-2

U

USB drive 1-2

V

verification kit
 contents 1-2
 data
 replacing 6-1
 frequency range 1-2
 overview 1-2
 performance
 how Keysight verifies 4-2
 visual inspection 3-4

W

wear, connector 3-4
 affect on electrical performance 3-4
 wrench
 open-end 3-13
 part number 6-2
 undoing connections 3-13
 torque 3-14
 part number 6-2
 wrist strap
 part number 6-2



This information is subject to change without notice.

© Keysight Technologies 2016-2017

Edition 1, June 2017

85059-90006

www.keysight.com